

Tel +1 952 995 8000
 Fax +1 952 995 8099
 www.emersonct.com

MODEL 306A - GRAPHIC COLOR LCD OPERATOR INTERFACE TERMINAL WITH TFT QVGA DISPLAY AND TOUCHSCREEN

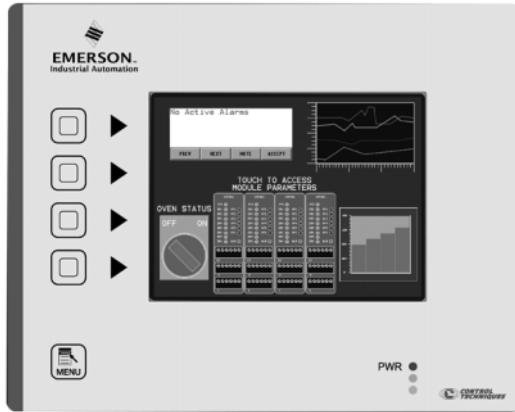

- CONFIGURED USING CTVue CONFIGURATOR SOFTWARE
- UP TO 5 RS-232/422/485 COMMUNICATIONS PORTS (2 RS-232 AND 1 RS-422/485 ON BOARD, 1 RS-232 AND 1 RS422/485 ON OPTIONAL COMMUNICATIONS CARD)
- 10 BASE T/100 BASE-TX ETHERNET PORT TO NETWORK UNITS AND HOST WEB PAGES
- USB PORT TO DOWNLOAD THE UNIT'S CONFIGURATION FROM A PC OR FOR DATA TRANSFERS TO A PC
- UNIT'S CONFIGURATION IS STORED IN NON-VOLATILE MEMORY (8 MBYTE FLASH)
- COMPACTFLASH® SOCKET TO INCREASE MEMORY CAPACITY
- 5.7-INCH TFT ACTIVE MATRIX 256 COLOR QVGA 320 X 240 PIXEL LCD
- 5-BUTTON KEYPAD FOR ON-SCREEN MENUS
- THREE FRONT PANEL LED INDICATORS
- POWER UNIT FROM 24 VDC ±20% SUPPLY
- RESISTIVE ANALOG TOUCHSCREEN



GENERAL DESCRIPTION

The CTVUE-306A Operator Interface Terminal combines unique capabilities normally expected from high-end units with a very affordable price. It is built around a high performance core with integrated functionality.

The 306 is able to communicate with many different types of hardware using high-speed RS232/422/485 communications ports and Ethernet 10 Base T/100 Base-TX communications. In addition, the 306 features USB for fast downloads of configuration files and access to trending and data logging. A CompactFlash socket is provided so that Flash cards can be used to collect your trending and data logging information as well as to store larger configuration files.

In addition to accessing and controlling of external resources, the 306 allows a user to easily view and enter information. Users can enter data through the touchscreen and/or front panel 5-button keypad.

ORDERING INFORMATION

DESCRIPTION	PART NUMBER
Operator Interface for indoor applications, textured finish with embossed keys	CTVUE-306A
CANopen Optional Communications Card	CTVUE-CN00
DeviceNet option card for operator interfaces with isolated high speed communications ports	CTVUE-DN00
RS 232/485 Optional Communication Card	CTVUE-RS00
Profibus DP Optional Communication Card	CTVUE-PBDP
CTVue Programming Software CD	CTVUE-CONFIG-CD
RS-232 Programming Cable	CTVUE-PROG
USB Cable	CTVUE-USB

CONTENTS OF PACKAGE

- 306A Operator Interface.
- Panel gasket.
- Template for panel cutout.
- Hardware packet for mounting unit into panel.
- Terminal block for connecting power.

SAFETY SUMMARY

All safety related regulations, local codes and instructions that appear in the manual or on equipment must be observed to ensure personal safety and to prevent damage to either the instrument or equipment connected to it. If equipment is used in a manner not specified by the manufacturer, the protection provided by the equipment may be impaired.

Do not use the controller to directly command motors, valves, or other actuators not equipped with safeguards. To do so can be potentially harmful to persons or equipment in the event of a fault to the controller.



The protective conductor terminal is bonded to conductive parts of the equipment for safety purposes and must be connected to an external protective earthing system.



CAUTION: Risk Of Danger.
 Read complete instructions prior to installation and operation of the unit.



CAUTION: Risk of electric shock.

CompactFlash is a registered trademark of CompactFlash Association.

SPECIFICATIONS

1. POWER REQUIREMENTS:

Must use Class 2 or SELV rated power supply.
Power connection via removable three position terminal block.

Supply Voltage: +24 VDC \pm 20%
Typical Power¹: 8 W
Maximum Power²: 14 W

Notes:

1. Typical power with +24 VDC, RS232/485 communications, Ethernet communications, CompactFlash card installed, and display at full brightness.
2. Maximum power indicates the most power that can be drawn from the 306. Refer to "Power Supply Requirements" under "Installing and Powering the 306."
3. The 306's circuit common is not connected to the enclosure of the unit. See "Connecting to Earth Ground" in the section "Installing and Powering the 306."
4. Read "Power Supply Requirements" in the section "Installing and Powering the 306" for additional power supply information.

2. **BATTERY:** Lithium coin cell. Typical lifetime of 10 years.

3. LCD DISPLAY:

SIZE	5.7-inch
TYPE	TFT
COLORS	256
PIXELS	320 X 240
BRIGHTNESS	500 cd/m ²
BACKLIGHT*	50,000 HR TYP.

*Lifetime at room temperature. Refer to "Display" in "Software/Unit Operation"

4. **5-KEY KEYPAD:** for on-screen menus.

5. **TOUCHSCREEN:** Resistive analog

6. MEMORY:

On Board User Memory: 8 Mbyte of non-volatile Flash memory.

Memory Card: CompactFlash Type II slot for Type I and Type II CompactFlash cards.

7. COMMUNICATIONS:

USB Port: Adheres to USB specification 1.1. Device only using Type B connection.

Serial Ports: Format and Baud Rates for each port are individually software programmable up to 115,200 baud.

PGM Port: RS232 port via RJ12.

COMMS Ports: RS422/485 port via RJ45, and RS232 port via RJ12.

DH485 TXEN: Transmit enable; open collector, $V_{OH} = 15$ VDC,
 $V_{OL} = 0.5$ V @ 25 mA max.

Note: For additional information on the communications or signal common and connections to earth ground please see the "Connecting to Earth Ground" in the section "Installing and Powering the 306."

Ethernet Port: 10 BASE-T / 100 BASE-TX

RJ45 jack is wired as a NIC (Network Interface Card).

Isolation from Ethernet network to CTVue operator interface: 1500 Vrms

8. ENVIRONMENTAL CONDITIONS:

Operating Temperature Range: 0 to 50°C

Storage Temperature Range: -20 to 70°C

Operating and Storage Humidity: 80% maximum relative humidity (non-condensing) from 0 to 50°C.

Altitude: Up to 2000 meters.

9. CERTIFICATIONS AND COMPLIANCES:

SAFETY

IEC 61010-1, EN 61010-1: Safety requirements for electrical equipment for measurement, control, and laboratory use, Part 1.

IP66 Enclosure rating (Face only), IEC 529

Type 4X Indoor Enclosure rating (Face only), UL50

ELECTROMAGNETIC COMPATIBILITY

Emissions and Immunity to EN 61326: Electrical Equipment for Measurement, Control and Laboratory use.

Immunity to Industrial Locations:

Electrostatic discharge	EN 61000-4-2	Criterion A 4 kV contact discharge 8 kV air discharge
Electromagnetic RF fields	EN 61000-4-3	Criterion A 10 V/m
Fast transients (burst)	EN 61000-4-4	Criterion A 2 kV power 1 kV signal
Surge	EN 61000-4-5	Criterion A 1 kV L-L, 2 kV L&N-E power
RF conducted interference	EN 61000-4-6	Criterion A 3 V/rms

Emissions:

Emissions	EN 55011	Class A
-----------	----------	---------

Note:

1. Criterion A: Normal operation within specified limits.

10. **CONNECTIONS:** Compression cage-clamp terminal block.

Wire Gage: 12-30 AWG copper wire

Torque: 5-7 inch-pounds (56-79 N-cm)

11. **CONSTRUCTION:** Steel rear metal enclosure with NEMA 4X/IP66 for indoor use aluminum front plate for indoor use only when correctly fitted with the gasket provided. Installation Category II, Pollution Degree 2.

12. **MOUNTING REQUIREMENTS:** Maximum panel thickness is 0.25" (6.3 mm). For NEMA 4X/IP66 for indoor use sealing, a steel panel with a minimum thickness of 0.125" (3.17 mm) is recommended.

Maximum Mounting Stud Torque: 17 inch-pounds (1.92 N-m)

13. **WEIGHT:** 3.0 lbs (1.36 Kg)

DIMENSIONS In inches (mm)

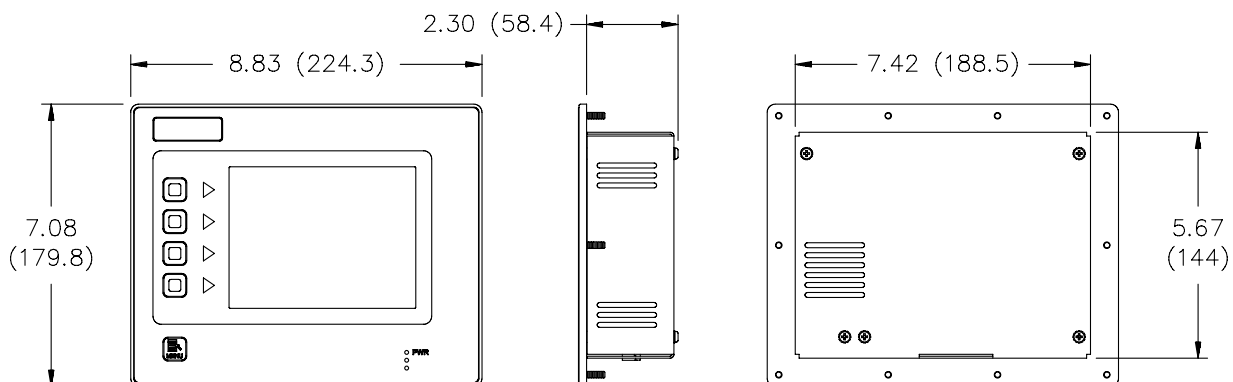

INSTALLING AND POWERING THE 306

MOUNTING INSTRUCTIONS

This operator interface is designed for through-panel mounting. A panel cut-out diagram and a template are provided. Care should be taken to remove any loose material from the mounting cut-out to prevent that material from falling into the operator interface during installation. A gasket is provided to enable sealing to NEMA 4X/IP66 for indoor use specification. Install the ten keps nuts provided and tighten evenly for uniform gasket compression.

Note: Tightening the keps nuts beyond a maximum of 17 inch-pounds (1.92 N-m) may cause damage to the front panel.

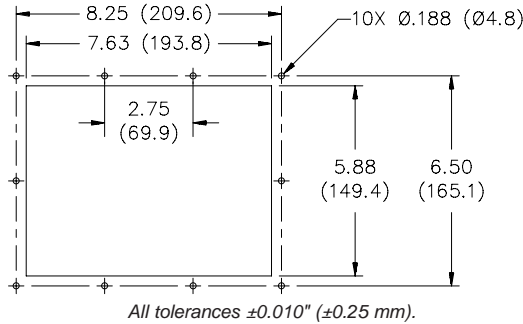

CONNECTING TO EARTH GROUND



The protective conductor terminal is bonded to conductive parts of the equipment for safety purposes and must be connected to an external protective earthing system.

Each 306 has a chassis ground terminal on the back of the unit. Your unit should be connected to earth ground (protective earth).

The chassis ground is not connected to signal common of the unit. Maintaining isolation between earth ground and signal common is not required to operate your unit. But, other equipment connected to this unit may require isolation between signal common and earth ground.

To maintain isolation between signal common and earth ground care must be taken when connections are made to the unit. For example, a power supply with isolation between its signal common and earth ground must be used. Also, plugging in a USB cable may connect signal common and earth ground.¹

¹ USB's shield may be connected to earth ground at the host. USB's shield in turn may also be connected to signal common.

POWER SUPPLY REQUIREMENTS

The 306 requires a 24 VDC power supply. Your unit may draw considerably less than the maximum rated power depending upon the options being used. As additional features are used your unit will draw increasing amounts of power. Items that could cause increases in current are additional communications, optional communications card, CompactFlash card, and other features programmed through CTVue Configurator.

In any case, it is very important that the power supply is mounted correctly if the unit is to operate reliably. Please take care to observe the following points:

- The power supply must be mounted close to the unit, with usually not more than 6 feet (1.8 m) of cable between the supply and the operator interface. Ideally, the shortest length possible should be used.
- The wire used to connect the operator interface's power supply should be at least 22-gauge wire. If a longer cable run is used, a heavier gauge wire should be used. The routing of the cable should be kept away from large contactors, inverters, and other devices which may generate significant electrical noise.
- A power supply with a Class 2 or SELV rating is to be used. A Class 2 or SELV power supply provides isolation to accessible circuits from hazardous voltage levels generated by a mains power supply due to single faults. SELV is an acronym for "safety extra-low voltage." Safety extra-low voltage circuits shall exhibit voltages safe to touch both under normal operating conditions and after a single fault, such as a breakdown of a layer of basic insulation or after the failure of a single component has occurred.

COMMUNICATING WITH THE 306

PROGRAMMING A 306

The 306 is programmed using CTVue Configurator software. The software is available as a free download from Control Techniques' website, or it can be ordered on CD. Updates to the software for new features and drivers are posted on the website as they become available. By programming the 306 using the latest version of the software, you are assured that your unit has the most up to date feature set. The software can program the 306 through the RS232 PGM port, USB port, or CompactFlash.

The USB port is connected using a standard USB cable with a Type B connector. The driver needed to use the USB port will be installed with the software.

The RS232 PGM port uses a programming cable made by Control Techniques to connect to the DB9 COM port of your computer. If you choose to make your own cable, use the "306 Port Pin Out Diagram" for wiring information.

The CompactFlash can be used to program a CTVue by placing a configuration file and firmware on the CompactFlash card. The card is then inserted into the target CTVue and powered. Refer to the CTVue literature for more information on the proper names and locations of the files.

USB, DATA TRANSFERS FROM THE COMPACTFLASH CARD



WARNING - DO NOT CONNECT OR DISCONNECT CABLES WHILE POWER IS APPLIED UNLESS AREA IS KNOWN TO BE NON-HAZARDOUS. USB PORT IS FOR SYSTEM SET-UP AND DIAGNOSTICS AND IS NOT INTENDED FOR PERMANENT CONNECTION.

In order to transfer data from the CompactFlash card via the USB port, a driver must be installed on your computer. This driver is installed with CTVue Configurator and is located in the folder C:\Program Files\Control Techniques\CTVUE \Device\ after CTVue Configurator is installed. This may have already been accomplished if your 306 was configured using the USB port.

Once the driver is installed, connect the 306 to your PC with a USB cable, and follow "Mounting the CompactFlash" instructions in the CTVue Configurator user manual.

ETHERNET COMMUNICATIONS

Ethernet communications can be established at either 10 BASE-T or 100 BASE-TX. The 306 unit's RJ45 jack is wired as a NIC (Network Interface Card). For example, when wiring to a hub or switch use a straight-through cable, but when connecting to another NIC use a crossover cable.

The Ethernet connector contains two LEDs. A yellow LED in the upper right, and a bi-color green/amber LED in the upper left. The LEDs represent the following statuses:

LED COLOR	DESCRIPTION
YELLOW solid	Link established.
YELLOW flashing	Data being transferred.
GREEN	10 BASE-T Communications
AMBER	100 BASE-TX Communications

On the rear of each unit is a unique 12-digit MAC address and a block for marking the unit with an IP address. Refer to the CTVue manual and Control Techniques' website for additional information on Ethernet communications.

RS232 PORTS

The 306 has two RS232 ports. There is the PGM port and the COMMS port. Although only one of these ports can be used for programming, both ports can be used for communications with a PLC.

The RS232 ports can be used for either master or slave protocols with any 306 configuration.

CTVue RS232 to a PC

Connections			
CTVue: RJ12	Name	PC: DB9	Name
4	COMM	1	DCD
5	Tx	2	Rx
2	Rx	3	Tx
	N/C	4	DTR
3	COM	5	GND
	N/C	6	DSR
1	CTS	7	RTS
6	RTS	8	CTS
	N/C	9	RI

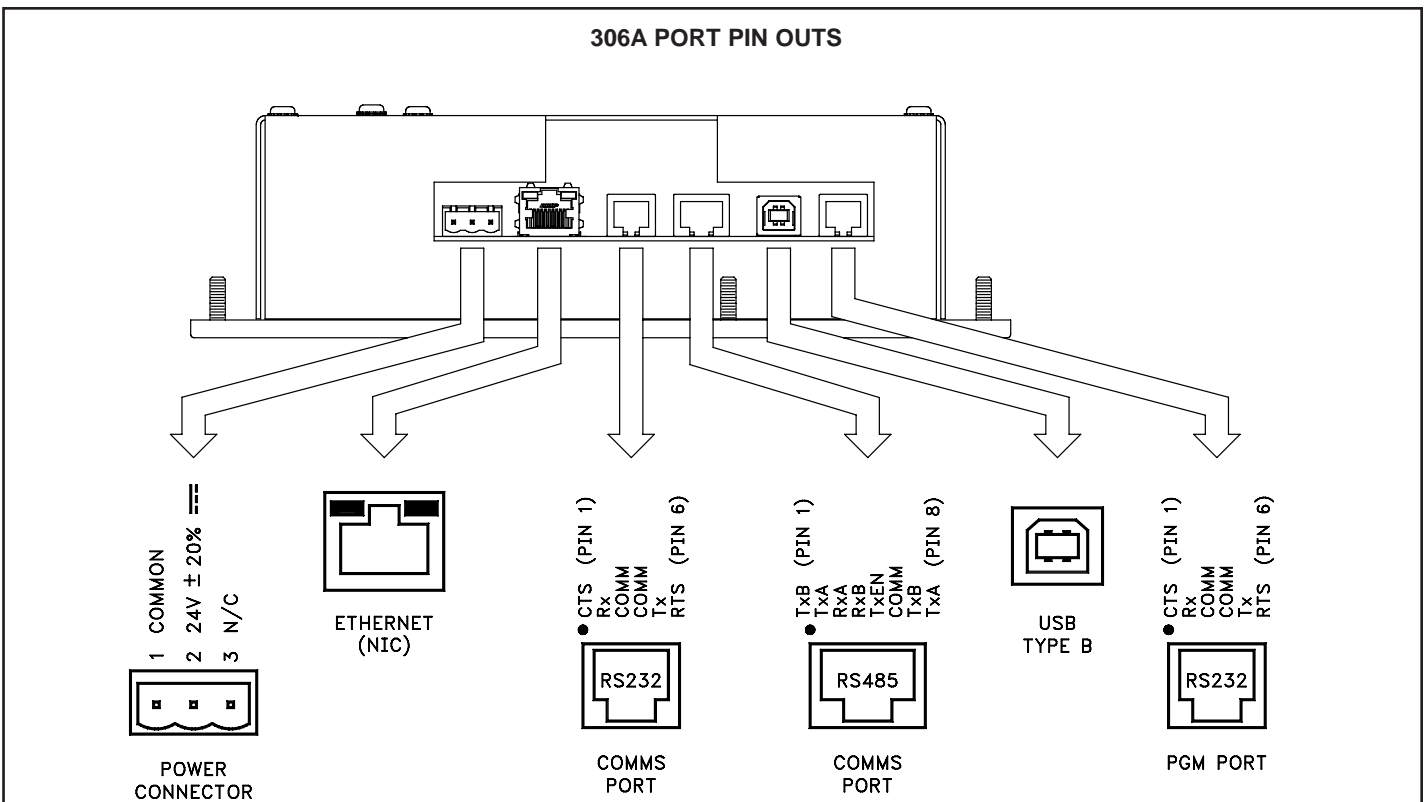

RS422/485 COMMS PORT

The 306 has one RS422/485 port. This port can be configured to act as either RS422 or RS485.

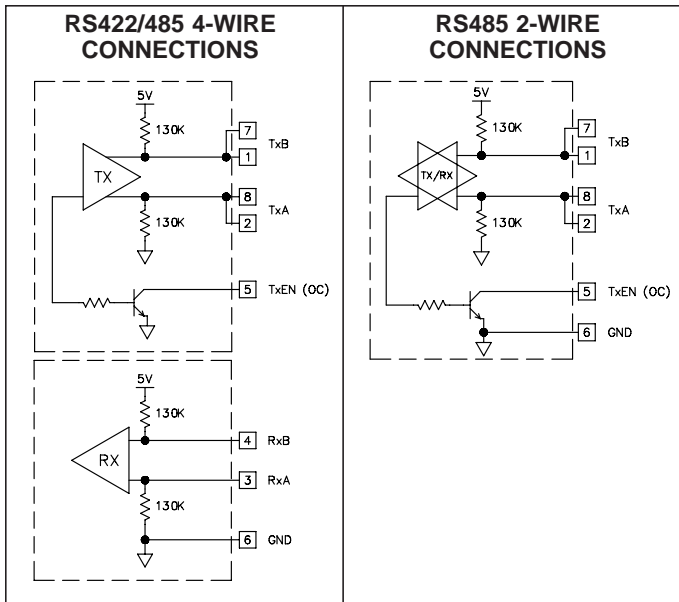

DH485 COMMUNICATIONS

The 306's RS422/485 COMMS port can also be used for Allen Bradley DH485 communications.

WARNING: DO NOT use a standard DH485 cable to connect this port to Allen Bradley equipment.

CTVue to AB SLC 500 (CBLAB003)

Connections			
RJ45: CTVue	Name	RJ45: A-B	Name
1	TxB	1	A
2	TxA	2	B
3, 8	RxA	-	24V
4, 7	RxB	-	COMM
5	TxEN	5	TxEN
6	COMM	4	SHIELD
4, 7	TxB	-	COMM
3, 8	TxA	-	24V

SOFTWARE/UNIT OPERATION

CTVue CONFIGURATOR SOFTWARE

CTVue Configurator software is available as a free download from Control Techniques' website or it can be ordered on a CD, see "Ordering Information" for part number. The latest version of the software is always available from the website, and updating your copy is free.

DISPLAY

This operator interface uses a liquid crystal display (LCD) for displaying text and graphics. The display utilizes a cold cathode fluorescent tube (CCFL) for lighting the display. The CCFL tubes can be dimmed for low light conditions.

These CCFL tubes have a limited lifetime. Backlight lifetime is based upon the amount of time the display is turned on at full intensity. Turning the backlight off when the display is not in use can extend the lifetime of your backlight. This can be accomplished through the CTVue Configurator software when programming your unit.

KEYPAD

The 306 keypad consists of five keys that can be used for on-screen menus.

TOUCHSCREEN

This operator interface utilizes a resistive analog touchscreen for user input. The unit will only produce an audible tone (beep) when a touch on an active touchscreen cell is sensed. The touchscreen is fully functional as soon as the operator interface is initialized, and can be operated with gloved hands.

FRONT PANEL LEDs

There are three front panel LEDs. Shown below is the default status of the LEDs.

LED	INDICATION
RED (TOP, LABELED "PWR")	
FLASHING	Unit is in the boot loader, no valid configuration is loaded. ¹
STEADY	Unit is powered and running an application.
YELLOW (MIDDLE)	
OFF	No CompactFlash card is present.
STEADY	Valid CompactFlash card present.
FLASHING RAPIDLY	CompactFlash card being checked.
FLICKERING	Unit is writing to the CompactFlash, either because it is storing data, or because the PC connected via the USB port has locked the drive. ²
FLASHING SLOWLY	Incorrectly formatted CompactFlash card present.
GREEN (BOTTOM)	
FLASHING	A tag is in an alarm state.
STEADY	Valid configuration is loaded and there are no alarms present.

¹ The operator interface is shipped without a configuration. After downloading a configuration, if the light remains in the flashing state continuously, try cycling power. If the LED still continues to flash, try downloading a configuration again.

² Do not turn off power to the unit while this light is flickering. The unit writes data in two minute intervals. Later Microsoft operating systems will not lock the drive unless they need to write data; Windows 98 may lock the drive any time it is mounted, thereby interfering with logging. Refer to "Mounting the CompactFlash" in the CTVue Configurator User Manual.

TROUBLESHOOTING YOUR 306

If for any reason you have trouble operating, connecting, or simply have questions concerning your new 306, contact Control Techniques' technical support. For contact information, refer to the front page of this bulletin for phone and fax numbers.

EMAIL: info@emersonct.com
Web Site: <http://www.emersonct.com>

BATTERY & TIME KEEPING



WARNING - EXPLOSION HAZARD - THE AREA MUST BE KNOWN TO BE NON-HAZARDOUS BEFORE SERVICING/ REPLACING THE UNIT AND BEFORE INSTALLING OR REMOVING I/O WIRING AND BATTERY.



WARNING - EXPLOSION HAZARD - DO NOT DISCONNECT EQUIPMENT UNLESS POWER HAS BEEN DISCONNECTED AND THE AREA IS KNOWN TO BE NON-HAZARDOUS.

A battery is used to keep time when the unit is without power. Typical accuracy of the 306 time keeping is less than one minute per month drift. The battery of a 306 unit does not affect the unit's memory, all configurations and data is stored in non-volatile memory.

To change the battery of a 306, remove power, cabling, and then the rear cover of the unit. To remove the cover, remove the four screws designated by the arrows on the rear of the unit. Then, by lifting the top side, hinge the cover, thus providing clearance for the connectors on the bottom side of the PCB as shown in the illustration below. Install in the reverse manner.

Remove the old battery* from the holder and replace with the new battery. Replace the rear cover, cables, and re-apply power. Using CTVue Configurator or the unit's keypad, enter the correct time and date.

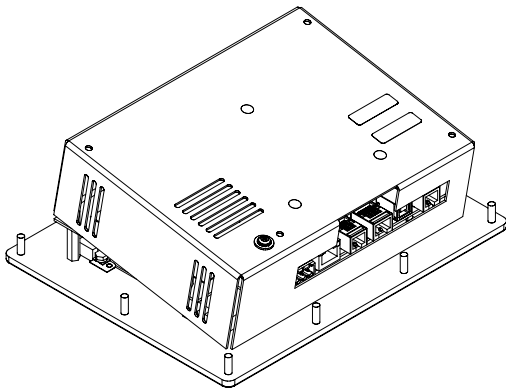

** Please note that the old battery must be disposed of in a manner that complies with your local waste regulations. Also, the battery must not be disposed of in fire, or in a manner whereby it may be damaged and its contents come into contact with human skin.*

The battery used by the 306 is a lithium type CR2025.



CAUTION: RISK OF ELECTRIC SHOCK

The inverter board, attached to the mounting plate, supplies the high voltage to operate the backlight. Touching the inverter board may result in injury to personnel.



CAUTION: The circuit board contains static sensitive components. Before handling the operator interface without the rear cover attached, discharge static charges from your body by touching a grounded bare metal object. Ideally, handle the operator interface at a static controlled clean workstation. Also, do not touch the surface areas of the circuit board. Dirt, oil, or other contaminants may adversely affect circuit operation.

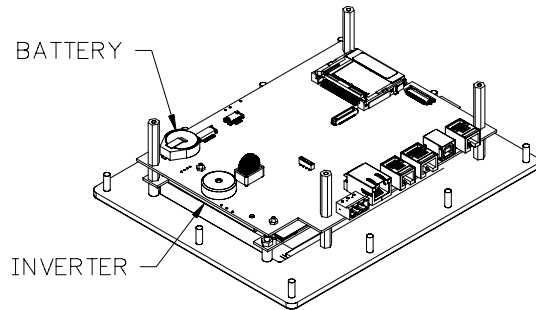
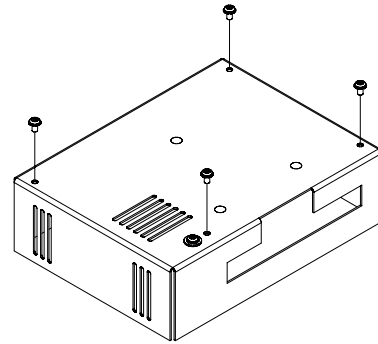

OPTIONAL FEATURES AND ACCESSORIES

COMPACTFLASH SOCKET

CompactFlash socket is a Type II socket that can accept either Type I or II cards. Use cards with a minimum of 4 Mbytes and a maximum of 2 Gbytes with the 306's CompactFlash socket. Cards are available at most computer and office supply retailers.

CompactFlash can be used for configuration transfers, larger configurations, data logging, and trending.

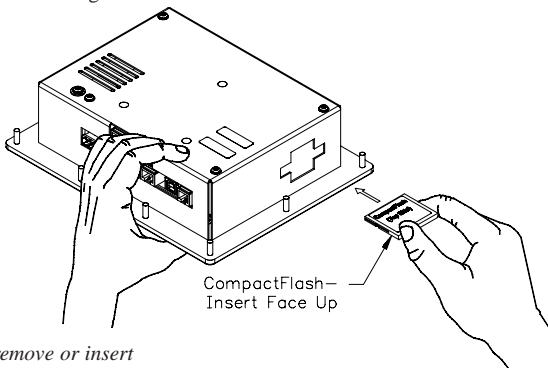

Note: Do not remove or insert the CompactFlash card while power is applied. Refer to "Front Panel LEDs."

Information stored on a CompactFlash card by a 306 can be read by a card reader attached to a PC. This information is stored in IBM (Windows®) PC compatible FAT16 file format.

OPTIONAL COMMUNICATION CARD

Control Techniques offers optional communication cards for fieldbus communications. These communication cards will allow your 306 to communicate with many of the popular fieldbus protocols.

Control Techniques is also offering a communications card for additional RS232 and RS422/485 communications. Visit Control Techniques' website for information and availability of these cards.