

# 1. VACON 100 X - MAINS SWITCH

## 1.1 MOUNTING INSTRUCTIONS - MM5 EXAMPLE

Document code: DPD00978B

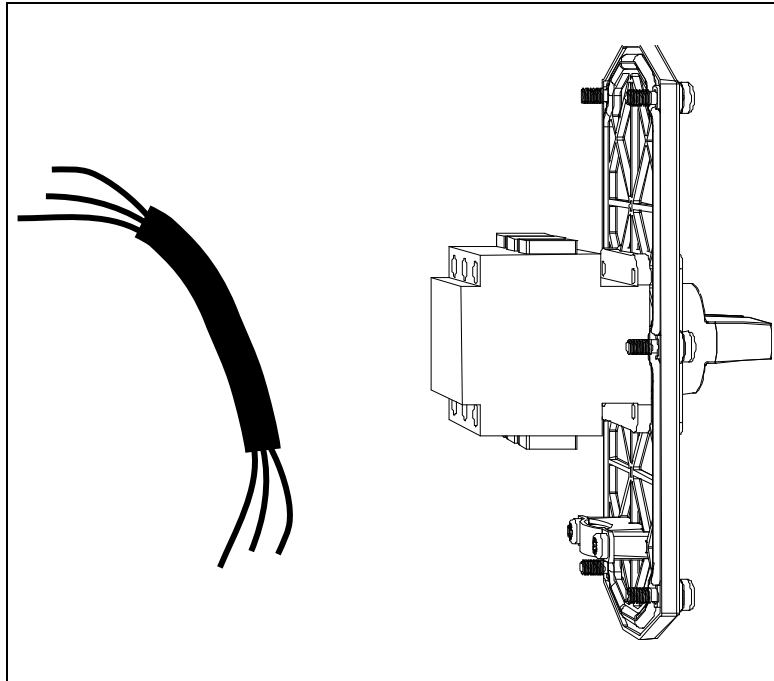

Figure 1. Content of the mains switch option package.

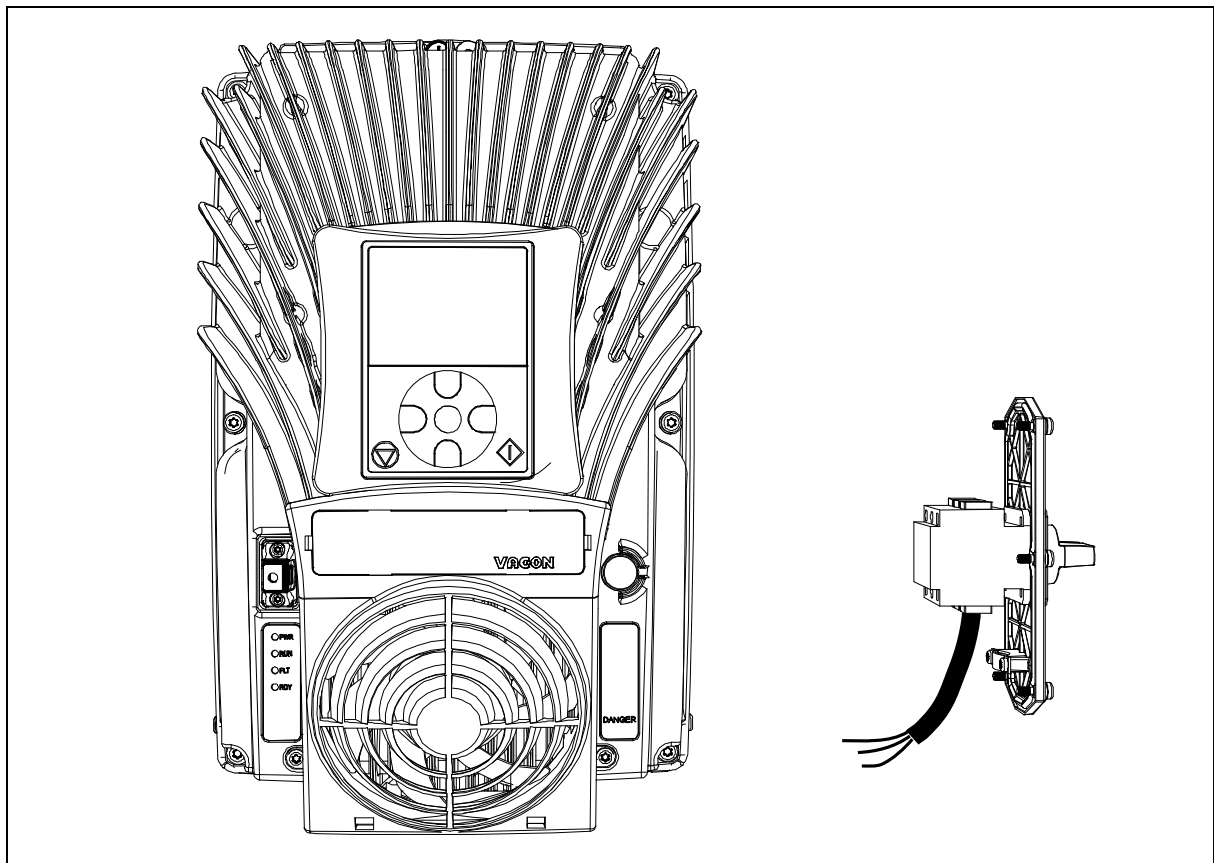

Figure 2. Drive and mains switch option.

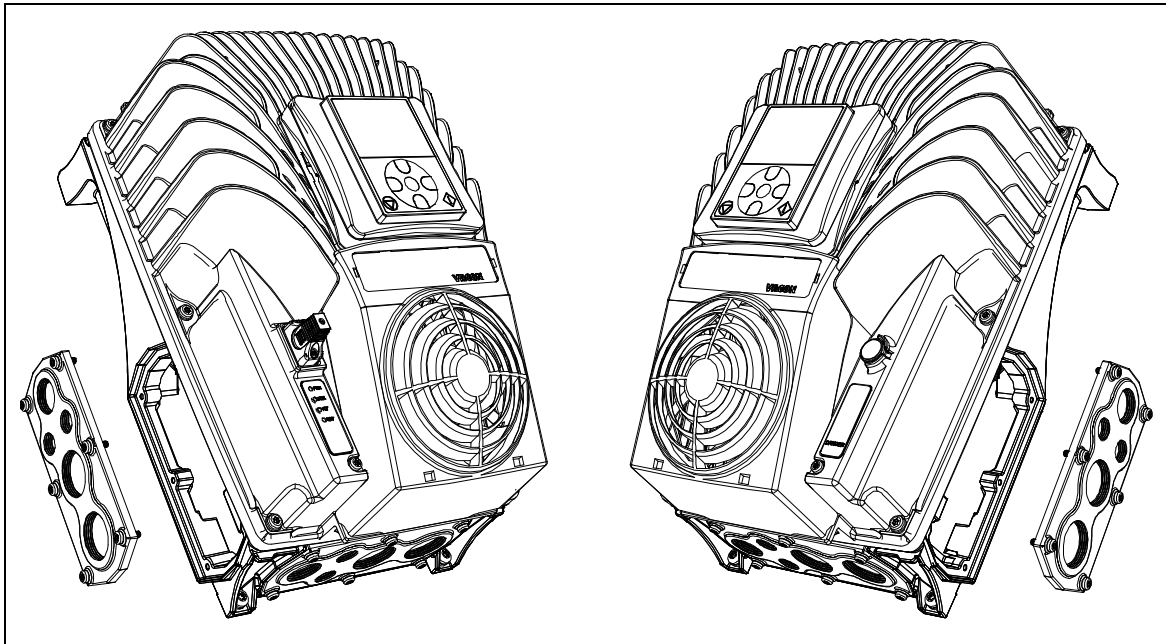

Figure 3. The mains switch can be mounted on either side of the drive. Disconnect the cable entry plate in which mains switch has to be mounted: example for MM5.

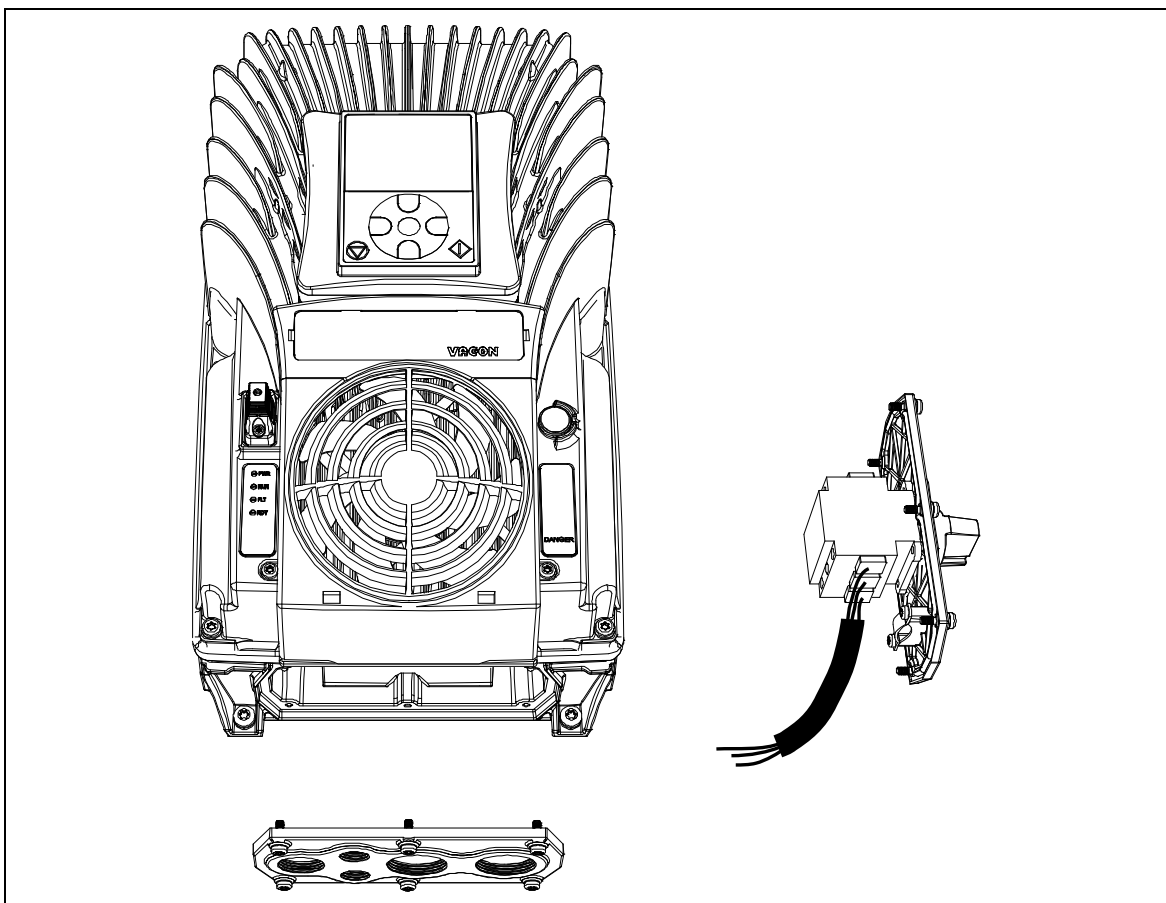

Figure 4. Cable entry plate from the bottom side of the drive from which the cables enter.

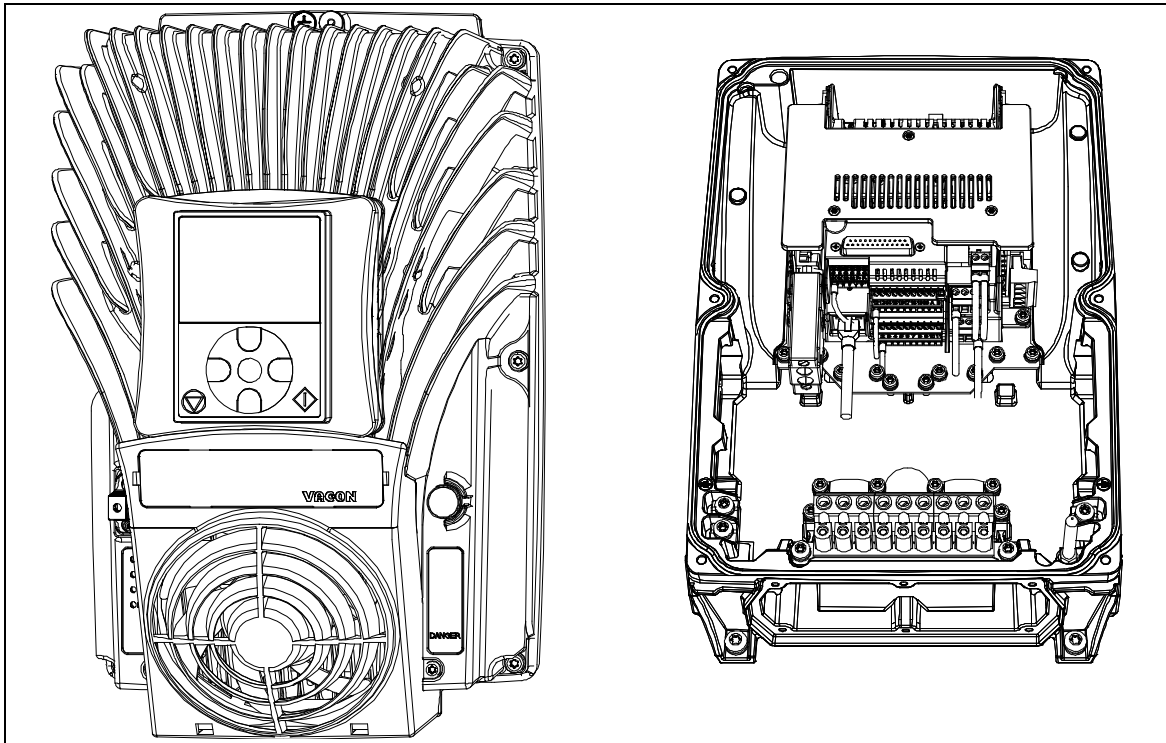

Figure 5. Powerhead separated from the terminal box.

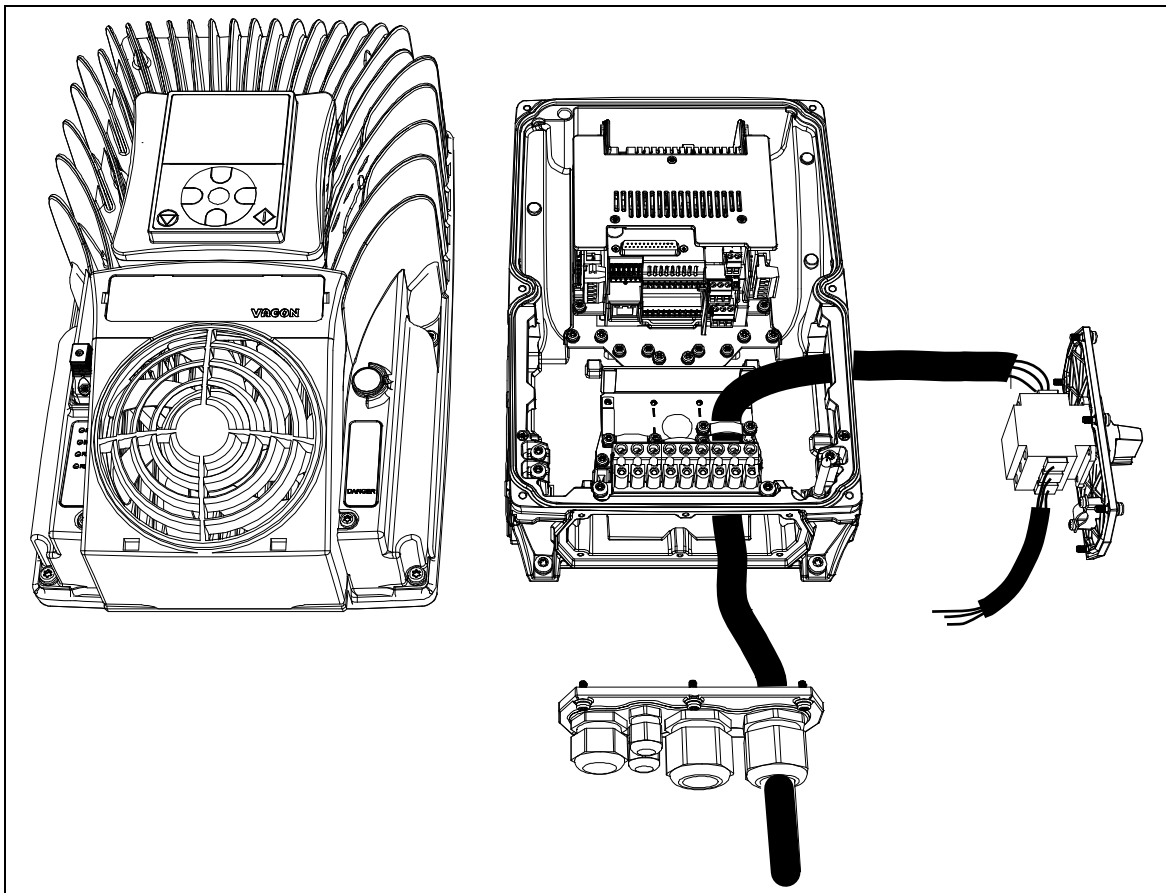

Figure 6. Connection of the supply cable to the Mains switch (right-hand-side example).

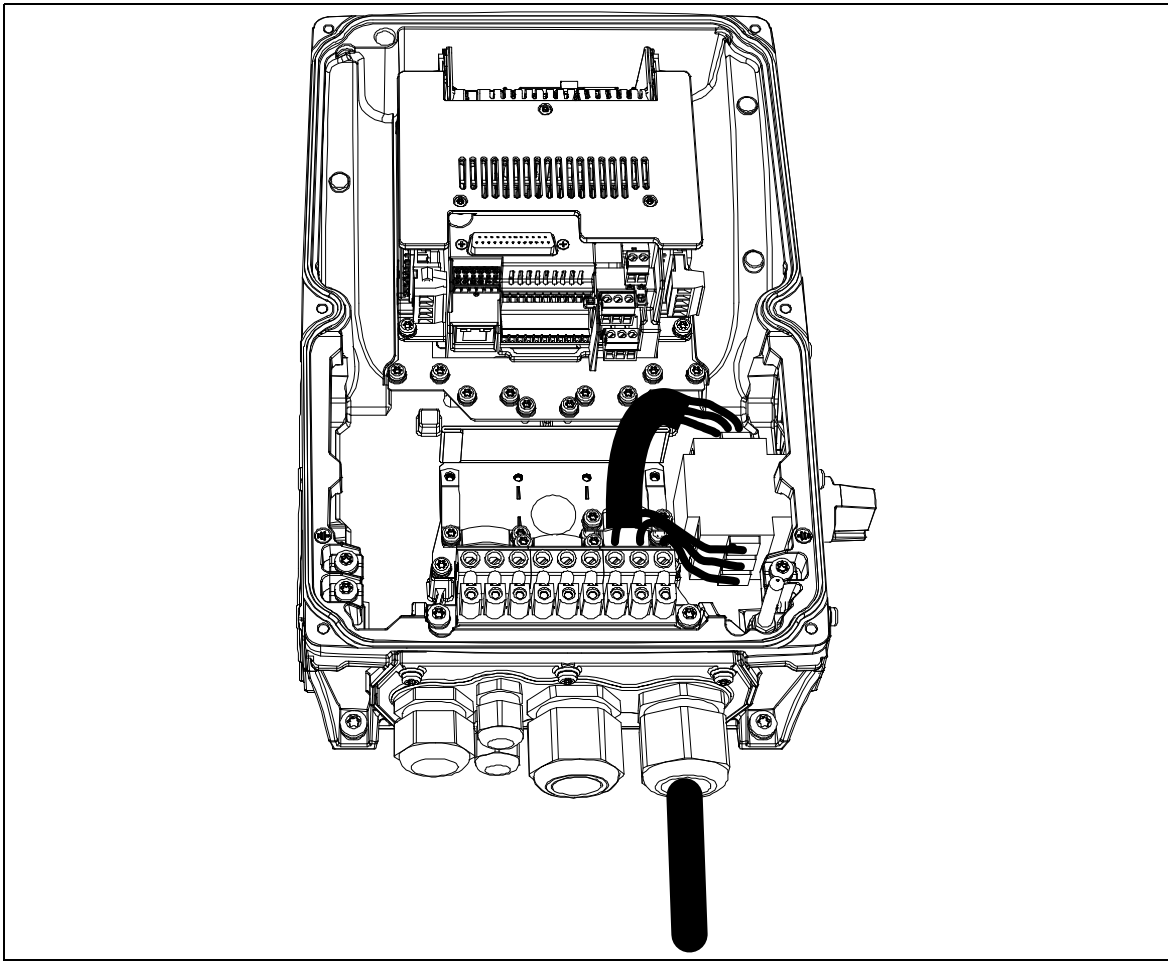

Figure 7. Mains switch, cable entry and cables connected.

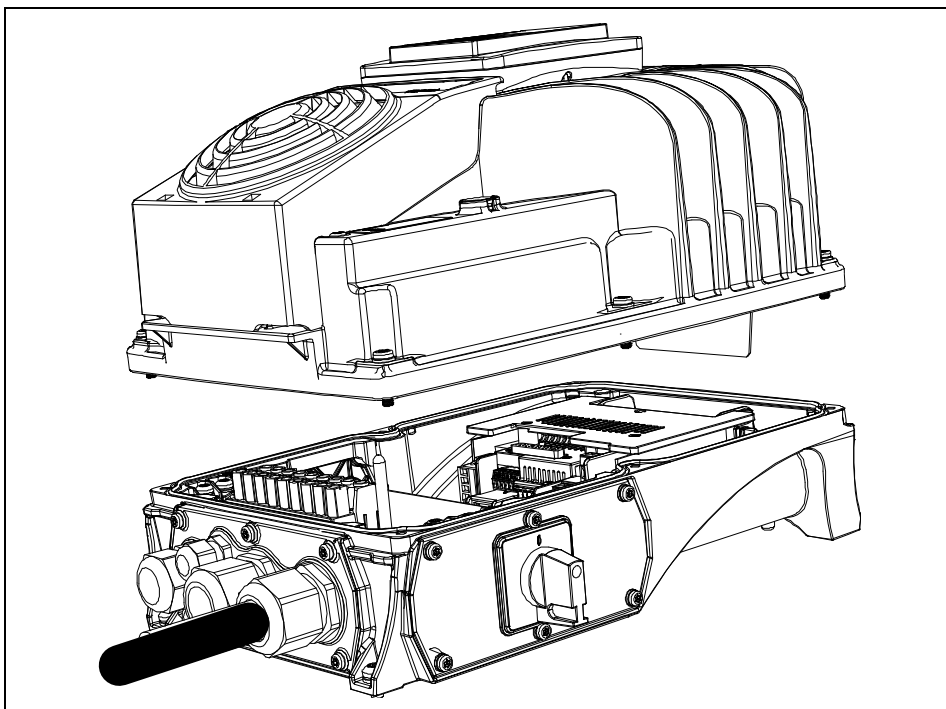

Figure 8. Mount the powerhead on the terminal box.