

P Series: INLINE – Solid Shaft Output

Standard Input

ServoCool Input Option

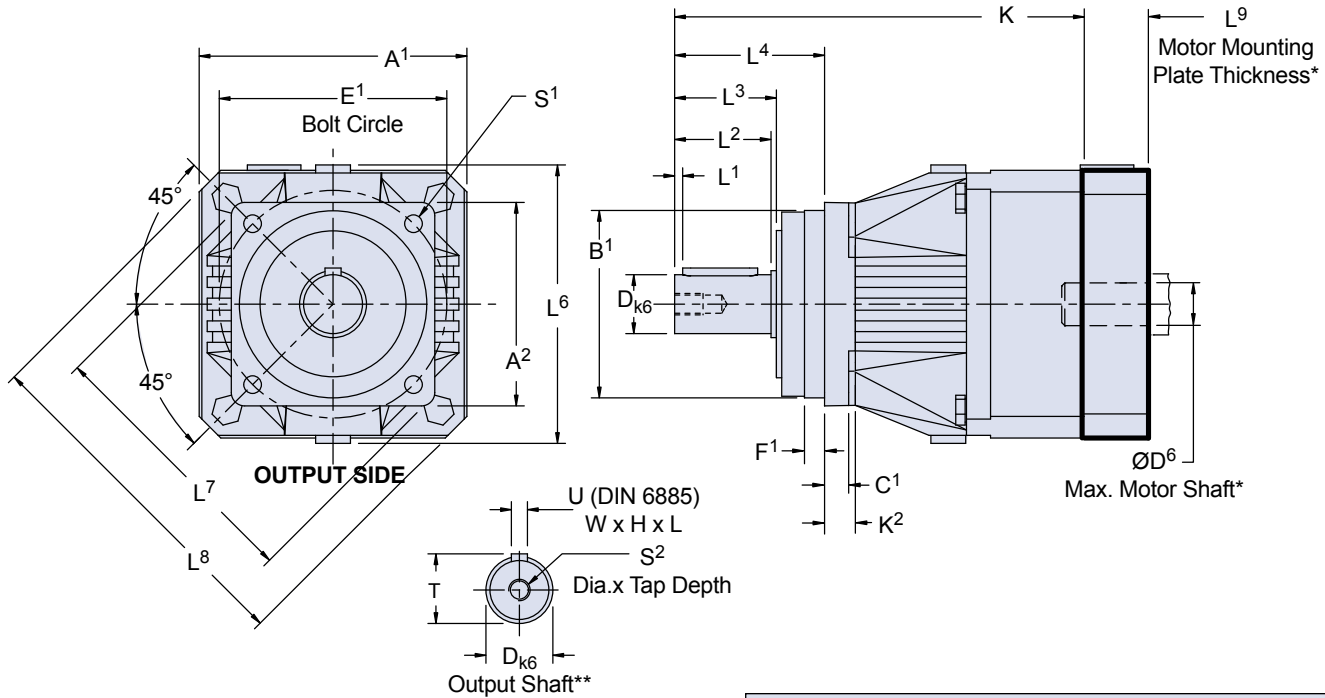

* See Motor Mounting Plate Option, page 15 for details.
** See Output Shaft Options, page 15 for details.

Table 1 Dimensions (mm)

Unit	A ¹	A ²	B ¹	h ₆	C ¹	D	k ₆	E ¹	F ¹	K ²
P221/P222	55	55	50	+0.000/-0.019	6	12	+0.012/+0.001	63	7	—
P321/P322	72	72	60	+0.000/-0.019	7	16	+0.012/+0.001	75	7.5	—
P421/P422	98	76	70	+0.000/-0.019	9	22	+0.015/+0.002	85	7.5	12
P521/P522	115	101	90	+0.000/-0.022	10	32	+0.018/+0.002	120	15	14
P721/P722	145	145	130	+0.000/-0.025	15	40	+0.018/+0.002	165	3.5	—
P821/P822	190	190	160	+0.000/-0.025	15	55	+0.021/+0.002	215	10	—
P921/P922	225	212	180	+0.000/-0.025	17	75	+0.021/+0.002	250	10	22

Table 2 Dimensions (mm)

Unit	L ¹	L ²	L ³	L ⁴	L ⁶	L ⁷	L ⁸	S ¹	S ²	T	U
P221/P222	2	22	24	36	62	74	80	5.5	M4x10	13.5	A4x4x18
P321/P322	2	28	30	48	79	92	92	5.5	M5x12.5	18	A5x5x22
P421/P422	3	36	38	56	98	103.3	130	6.6	M8x19	24.5	A6x6x28
P521/P522	3	58	60	88	121	139	149	9	M12x28	35	A10x8x50
P721/P722	4	82	85	112	145	—	190	11	M16x36	43	A12x8x70
P821/P822	6	82	85	112	190	—	250	13.5	M20x42	59	A16x10x70
P921/P922	7	105	109	143	225	285	300	17.5	M20x42	79.5	A20x12x90

Table 3 Dimensions (mm)

K	
Standard	ServoCool
P221 94.5	—
P222 126.5	—
P321 135	—
P322 158.5	—
P421 153	P421_C 176.5
P422 200.5	—
P521 193	P521_C 221
P522 242.5	P522_C 266
P721 242	P721_C 272
P722 294	P722_C 322
P821 283	P821_C 331
P822 350.5	P822_C 380.5
P921 353	P921_C 418
P922 441	P922_C 489



Dimensional Data

Large Input Option

P
INLINE – Solid Shaft Output

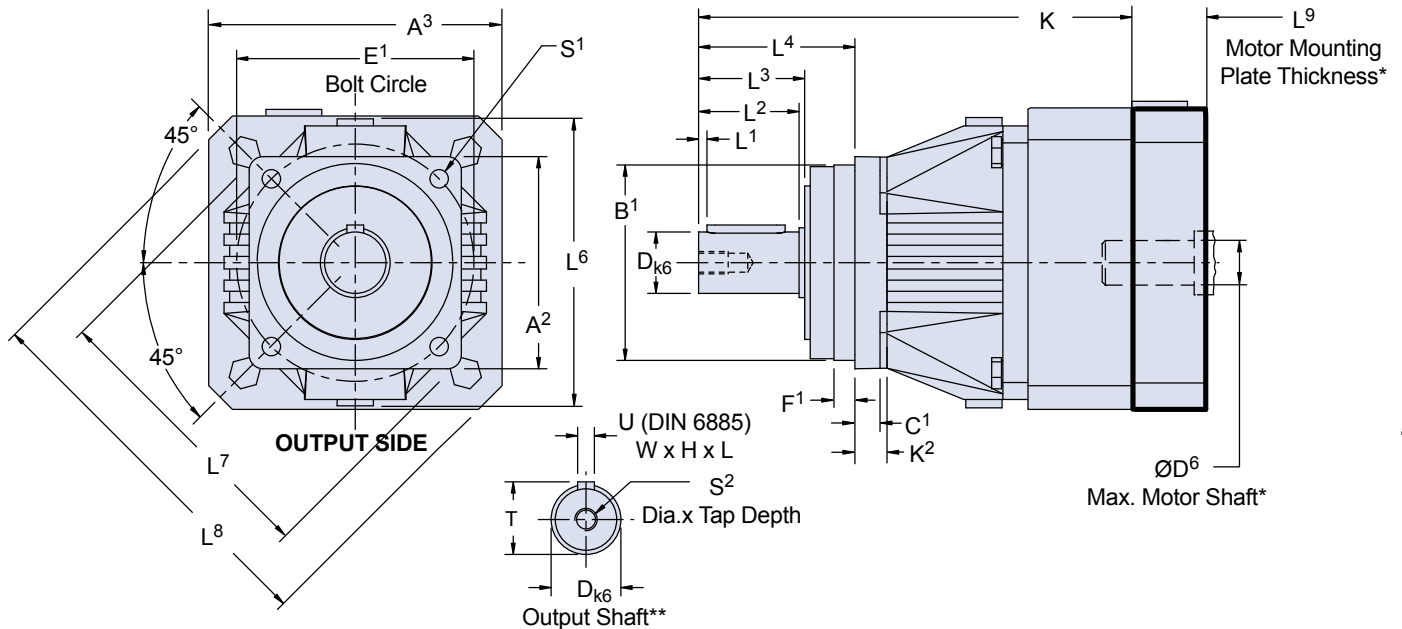

* See Motor Mounting Plate Option, page 15 for details.
** See Output Shaft Options, page 15 for details.

Table 1 Dimensions (mm)

Unit	A ²	B ¹	h ₆	C ¹	D	k ₆	E ¹	F ¹	K ²
P221/P222_L	55	50	+0.000/-0.019	6	12	+0.012/+0.001	63	7	—
P321/P322_L	72	60	+0.000/-0.019	7	16	+0.012/+0.001	75	7.5	—
P421/P422_L	76	70	+0.000/-0.019	9	22	+0.015/+0.002	85	7.5	12
P521/P522_L	101	90	+0.000/-0.022	10	32	+0.018/+0.002	120	15	14
P721/P722_L	145	130	+0.000/-0.025	15	40	+0.018/+0.002	165	3.5	—
P821/P822_L	190	160	+0.000/-0.025	15	55	+0.021/+0.002	215	10	—
P922_L	212	180	+0.000/-0.025	17	75	+0.021/+0.002	250	10	22

Table 2 Dimensions (mm)

Unit	L ¹	L ²	L ³	L ⁴	L ⁶	L ⁷	S ¹	S ²	T	U
P221/P222_L	2	22	24	36	92	74	5.5	M4x10	13.5	A4x4x18
P321/P322_L	2	28	30	48	130	92	5.5	M5x12.5	18	A5x5x22
P421/P422_L	3	36	38	56	149	103.3	6.6	M8x19	24.5	A6x6x28
P521/P522_L	3	58	60	88	190	139	9	M12x28	35	A10x8x50
P721/P722_L	4	82	85	112	250	—	11	M16x36	43	A12x8x70
P821/P822_L	6	82	85	112	190	—	13.5	M20x42	59	A16x10x70
P922_L	7	105	109	143	225	285	17.5	M20x42	79.5	A20x12x90

Table 3 Dimensions (mm)

Size	A ³	K	L ⁸
P221_L	75	111	100
P222_L	75	143	100
P321_L	100	138.3	130
P322_L	75	175	100
P421_L	115	161.5	149
P422_L	100	203.8	130
P521_L	145	207	190
P522_L	115	251	149
P721_L	190	259	250
P722_L	145	308	190
P821_L	225	291	300
P822_L	190	367.5	250
P922_L	225	449	300