

ZAE

WITH FULLY SPLIT CLAMPING HUB

10 - 800 Nm



ABOUT

FEATURES

- ▶ for spanning larger distances between shaft ends
- ▶ standard lengths up to 6 meters
- ▶ no intermediate support bearings required
- ▶ extremely straight and laterally stiff intermediate tube

- ▶ **Intermediate tube:** up to size 150 aluminum, size 300 and up steel
- ▶ **Hubs:** up to size 60 aluminum, size 150 and up steel

MATERIAL

- ▶ **Bellows:** high grade stainless steel

DESIGN

Two clamping hubs with two clamping screws in each. A special support system carries the weight of the tube on the hubs. Operable temperature range from -30 to +100 °C.

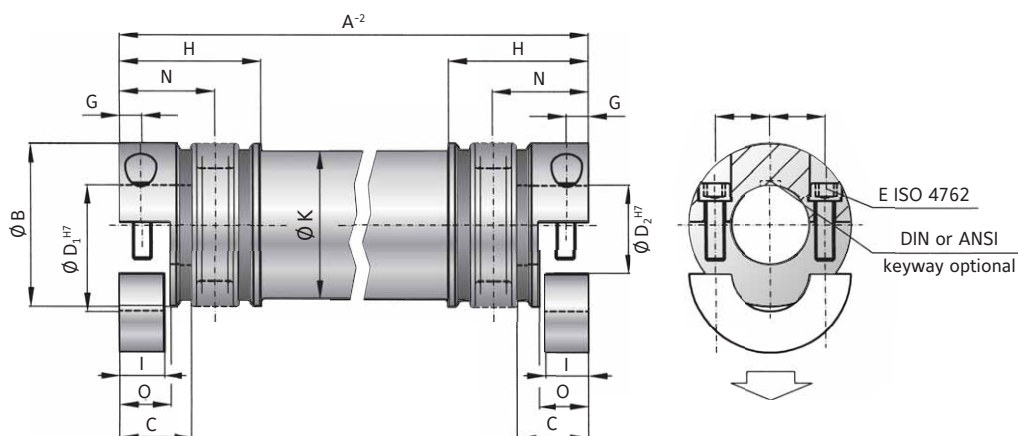

MODEL ZAE

SIZE			10	30	60	150	300	500	800
Rated torque (Nm)	T_{KN}		10	30	60	150	300	500	800
Overall length min. to max. (mm)	A^{-2}		100 - 6000	130 - 6000	160 - 6000	180 - 6000	240 - 6000	250 - 6000	250 - 6000
Outside diameter clamping hub (mm)	B		40	55	66	81	110	123	133
Fit length (mm)	C		16	27	31	34.5	42	50	47
Inside diameter from \emptyset to \emptyset H7 (mm)	$D_{1/2}$		5 - 20	10 - 28	12 - 32	19 - 42	30 - 60	35 - 60	40 - 72
Max. inside diameter clamping hub (mm)	D_{max}		24	30	32	42	60	60	75
With keyway - max \emptyset H7 (mm)	$D_{1/2}$		17	23	29	36	60	60	66
ISO 4762 clamping screws	E		M4	M6	M8	M10	M12	M16	M16
Tightening torque (Nm)			5	15	40	70	130	200	250
Distance between centers (mm)	F		15	19	23	27	39	41	48
Distance (mm)	G		5	7.5	9.5	12	14	17	19
Length bellows body (mm)	H		39.5	52	64	72	83	96	95
Clamping length (mm)	I		10	15	19	22	28	33.5	37.5
Outside diameter tube section (mm)	K		35	50	60	76	100	110	120
Length (mm)	O		11.5	17	21	24	30	35	40
Shaft average value (mm)	N		25	34	41	47	56	66	65

For maximum misalignment values see page 16.

ORDERING EXAMPLE	ZAE	10	1551	18	19.05	XX
Model	●					
Size		●				
Overall length mm			●			
Bore D1 H7				●		
Bore D2 H7					●	
For custom features place an XX at the end of the part number and describe the special requirements (e.g. ZAE / 10 / 1551 / 18 / 19.05 / XX; XX=anodized aluminum)						

Special designation only (e.g. special bore tolerance).