

SIZING AND SELECTION



According to
DIN 740 part 2

SIZING AND SELECTION

BELLOWS COUPLINGS



SYMBOLS

- T_{KN} = Rated torque of the coupling (Nm)
- T_{AS} = Peak torque of the drive system
e.g. max. acceleration torque of drive (Nm)
or max. braking torque of load (Nm)
- J_L = Total load inertia
(e.g. spindle + slide + workpiece + 1/2 of coupling) (kgm²)
- J_A = Total driving inertia
(motor [including gear ratio] + 1/2 of coupling) (kgm²)
- C_T = Torsional stiffness of the coupling (Nm/rad)
- f_e = Natural frequency of the two mass system (Hz)
- f_{er} = Excitation frequency of the drive (Hz)
- φ = Torsional deflection (degree)

Shock or Load Factor S_A		
uniform load	non-uniform load	highly dynamic load
1	2	3-4
Common factor for servo drives in machine tools: $S_A = 2-3$		

ACCORDING TO TORQUE

Couplings are normally sized for the highest torque to be regularly transmitted. The peak torque of the application should not exceed the rated torque of the coupling. The following calculation provides an approximation of the minimum required coupling size, and allows for the maximum rated speed and misalignment to exist in the application:

$$T_{KN} \cong 1.5 \cdot T_{AS} \text{ (Nm)}$$

ACCORDING TO ACCELERATION TORQUE

A more detailed calculation takes acceleration and the driving and driven moments of inertia into account. A strong inertia ratio diminishes the effect of the load factor in the sizing calculation.

$$T_{KN} \cong T_{AS} \cdot S_A \cdot \frac{J_L}{J_A + J_L} \text{ (Nm)}$$

ACCORDING TO RESONANT FREQUENCY

The torsional natural frequency of the coupling must be significantly higher or lower than that of the equipment. For the mechanical substitution model the two mass system applies.

$$f_e = \frac{1}{2 \cdot \pi} \sqrt{C_T \cdot \frac{J_A + J_L}{J_A \cdot J_L}} \text{ (Hz)}$$

In practice the following applies: $f_e \geq 2 \cdot f_{er}$

Two Mass System

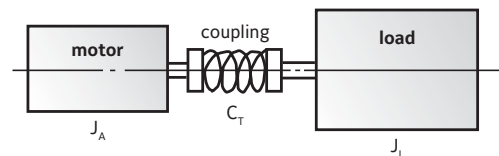

ACCORDING TO TORSIONAL DEFLECTION

To calculate transmission error as a result of torsional stress:

$$\varphi = \frac{180}{\pi} \cdot \frac{T_{AS}}{C_T} \text{ (degree)}$$

SIZING AND SELECTION

ELASTOMER COUPLINGS

EK

TX

ES

SYMBOLS

- T_{KN} = Rated torque of the coupling (Nm)
 T_{Kmax} = Maximum torque rating of the coupling (Nm)
 T_S = Peak torque applied to the coupling (Nm)
 T_{AS} = Peak torque of the drive system (Nm)
 T_{AN} = Nominal torque of the drive system (Nm)
 T_{LN} = Nominal torque of the load (Nm)
 P = Drive power (kW)
 n = Rotational speed (min.⁻¹)
 J_A = Total driving inertia
 (motor [including gear ratio] + 1/2 of coupling) (kgm²)
 J_L = Total load inertia
 (e.g. spindle + slide + workpiece + 1/2 of coupling) (kgm²)
 J_1 = Moment of inertia of driving coupling half (kgm²)
 J_2 = Moment of inertia of driven coupling half (kgm²)
 m = ratio of the moment of inertia of the drive to the load
 v = Temperature at the coupling (observed radiant heat)
 S_v = Temperature factor
 S_A = Load factor
 S_z = Start factor (factor for the number of starts per hour)
 Z_h = Number of starts per hour (1/h)

Temperature factor S_v	A	B	C	E
Temperature (v)	Sh 98 A	Sh 64 D	Sh 80 A	Sh 64 D
> -30°C to -10°C	1.5	1.3	1.4	1.2
> -10°C to +30°C	1.0	1.0	1.0	1.0
> +30°C to +40°C	1.2	1.1	1.3	1.0
> +40°C to +60°C	1.4	1.3	1.5	1.2
> +60°C to +80°C	1.7	1.5	1.8	1.3
> +80°C to +100°C	2.0	1.8	2.1	1.6
> +100°C to +120°C	-	2.4	-	2.0
> +120°C to +150°C	-	-	-	2.8

Start factor S_z			
Z_h	up to 120	120 to 240	over 240
S_z	1.0	1.3	contact us

Shock or Load Factor S_A		
uniform load	non-uniform load	highly dynamic load
1	1.8	2.5

COUPLING SELECTION FOR OPERATION WITHOUT SHOCK OR REVERSAL

The rated torque of coupling (T_{KN}) must be greater than the rated torque of the load (T_{LN}), taking into account the temperature at the coupling (Temperature factor S_v). Should T_{LN} be unknown, T_{AN} can be used as a substitute in the formula.

Calculation

$$T_{KN} > T_{AN} \cdot S_v$$

Supplemental Calculation

$$T_{AN} = \frac{9,550 \cdot P}{n}$$

Sample calculation: (without shock loads)

Coupling conditions

$$v = 70^\circ \text{C}$$

$$S_v = 1.7 \text{ (or } 70^\circ \text{ Elastomer Type A)}$$

Drive for centrifugal pump

$$T_{AN} = 85 \text{ Nm}$$

Calculation: $T_{KN} > T_{AN} \times S_v$

$$T_{KN} > 85 \text{ Nm} \cdot 1,7$$

$$T_{KN} > \underline{144.5 \text{ Nm}} \longrightarrow \text{Result: Coupling model EK2/150/A } (T_{KN} = 160 \text{ Nm}) \text{ is selected.}$$

COUPLING SELECTION FOR OPERATION WITH SHOCK LOADS

Same basic conditions as above. In addition, the maximum torque rating of the coupling (T_{Kmax}) is dictated by peak torque (T_s) due to shock loads.

Calculation

$$T_{KN} > T_{AN} \cdot S_v$$

Supplemental Calculation

$$T_{AN} = \frac{9,550 \cdot P}{n}$$

Calculation

$$T_{Kmax} > T_s \cdot S_z \cdot S_v$$

Supplemental Calculation

$$T_s = \frac{T_{AS} \cdot S_A}{m + 1}$$

$$m = \frac{J_A \cdot J_1}{J_L \cdot J_2}$$

SIZING AND SELECTION

SAFETY COUPLINGS

SK

SL

ES

SYMBOLS

T_{KN}	= Rated torque of the coupling (Nm)
T_{AN}	= Load torque (Nm)
T_{AS}	= Peak torque of the motor (Nm)
J_L	= Moment of inertia of the load (kgm ²)
J_A	= Moment of inertia of the drive (kgm ²)
P_{AN}	= Drive power (kW)
α	= Angular acceleration $\frac{1}{s^2}$
t	= Acceleration / deceleration time (s)
ω	= Angular velocity (1/s)
n	= Drive speed (min ⁻¹)
s	= Screw lead (mm)
F_V	= Feed force (N)
η	= Spindle efficiency
d_0	= pinion dia. (pulley) (mm)
C_T	= Torsional stiffness of the coupling (Nm/rad)
$J_{Masch.}$	= Total load inertia (e.g. spindle + slide + workpiece + 1/2 of coupling) (kgm ²)
$J_{Mot.}$	= Total driving inertia (motor [including gear ratio] + 1/2 of coupling) (kgm ²)
f_e	= Natural frequency of the two mass system (Hz)
φ	= Torsional deflection (degree)

Shock or Load Factor S_A

uniform load	non-uniform load	highly dynamic load
1	2	3

Common factor for servo drives in machine tools: $S_A = 2-3$

ACCORDING TO DISENGAGEMENT TORQUE

Torque limiters are generally selected according to the required disengagement torque, which must be greater than the torque required for regular operation. The disengagement of the torque limiter is most commonly determined in accordance with the drive data. For this purpose, the following calculation applies:

$$T_{KN} \geq 1.5 \cdot T_{AS} \text{ (Nm)}$$

or

$$T_{KN} \geq 9,550 \cdot \frac{P_{AN}}{n} \cdot 1.5 \text{ (Nm)}$$

ACCORDING TO ACCELERATION (START-UP WITH NO LOAD)

$$T_{KN} \cong \alpha \cdot J_L \cong \frac{J_L}{J_A + J_L} \cdot T_{AS} \cdot S_A \text{ (Nm)}$$

$$\alpha = \frac{\omega}{t} = \frac{\pi \cdot n}{t \cdot 30}$$

ACCORDING TO ACCELERATION WITH LOAD (START-UP UNDER LOAD)

$$T_{KN} \cong \alpha \cdot J_L + T_{AN} \cong \left[\frac{J_L}{J_A + J_L} \cdot (T_{AS} - T_{AN}) + T_{AN} \right] \cdot S_A \text{ (Nm)}$$

ACCORDING TO LINEAR FEED FORCE

Spindle Drive (ball screw / lead screw)

$$T_{AN} = \frac{s \cdot F_v}{2,000 \cdot \pi \cdot \eta} \text{ (Nm)}$$

Belt Drive / Chain Drive

$$T_{AN} = \frac{d_0 \cdot F_v}{2,000} \text{ (Nm)}$$

ACCORDING TO RESONANT FREQUENCY (SK2 / SK3 / SK5 WITH METAL BELLOWS - ES2 / ESL WITH ELASTOMER RING)

The torsional natural frequency of the coupling must be significantly higher or lower than that of the equipment. For the mechanical substitution model the two mass system applies:

$$f_e = \frac{1}{2 \cdot \pi} \sqrt{C_T \cdot \frac{J_{Masch} + J_{Mot}}{J_{Masch} \cdot J_{Mot}}} \text{ (Hz)}$$

ACCORDING TO TORSIONAL DEFLECTION (SK2 / SK3 / SK5 WITH METAL BELLOWS - ES2 / ESL WITH ELASTOMER RING)

To calculate transmission error as a result of torsional stress:

$$\varphi = \frac{180}{\pi} \cdot \frac{T_{AN}}{C_T} \text{ (degree)}$$

ACCORDING TO LOAD HOLDING FUNCTION SYSTEM

► Load Holding Version

The SK1, SKP, and SKN models in the load holding version can secure a minimum of 2x their torque setting after disengagement. The SK2, SK3, and SK5 models can secure

only up to the torque rating of the flexible bellows after disengagement.

SIZING AND SELECTION

LINE SHAFTS

ZA EZ

SYMBOLS

- A = Total length (mm)
- AB = Distance between flexures (mm)
AB = (A - 2xN)
- Z = Tube length (mm)
Z = (A - 2xH)
- H = Length of coupling ends (mm)
- N = Length to flexure (mm)
- T_{AS} = Peak torque of the drive (Nm)
- φ = Torsional deflection (degree)
- C_T^B = Torsional stiffness of both flexible elements (Nm/rad)
- C_T^{ZWR} = Torsional stiffness per 1m of tubing (Nm/rad)
- C_T^{ZA} = Total torsional stiffness (Nm/rad)
- n_k = Critical speed (1/min.)
- C_{Tdyn}^E = Dynamic torsional stiffness of both elastomer inserts (Nm/rad)
- C_{Tdyn}^{EZ} = Total torsional stiffness (Nm/rad)

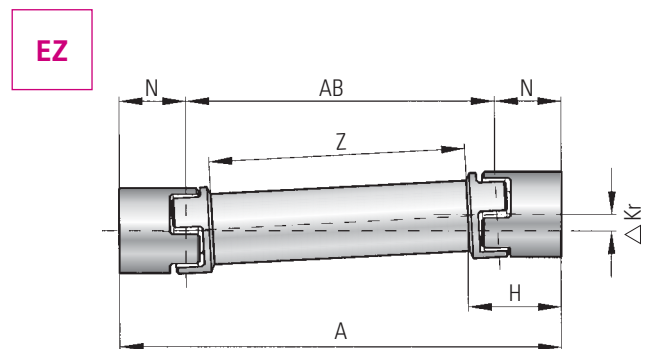
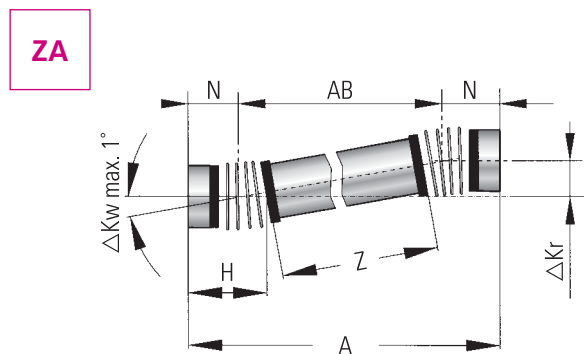

MODEL ZA

Size	Torsional stiffness of both bellows bodies C _T ^B (Nm/rad)	Torsional stiffness per 1m of standard tubing C _T ^{ZWR} (Nm/rad)	Torsional stiffness per 1m of CFK tubing C _T ^{ZWR} (Nm/rad)	Length of coupling ends ZA H (mm)	Length of coupling ends ZAE H (mm)	Length to flexure N (mm)	Maximum Axial misalignment Δ Ka (mm)
10	4,525	1,770	3,690	44.5	39.5	25	2
30	19,500	6,440	13,390	57.5	52	34	2
60	38,000	11,500	23,850	71	64	41	3
150	87,500	24,000	50,050	78	72	47	4
200	95,500	73,000	-	86	-	52	4
300	250,500	220,000	151,510	94	83	56	4
500	255,000	297,000	204,250	110	96	66	5
800	475,000	389,000	267,620	101	89	64	6
1500	1,400,000	775,000	-	92	-	56	4
4000	4,850,000	1,160,000	-	102	-	61	4

Table 1

MODEL EZ

Size	Torsional stiffness of both flexible elements		Torsional stiffness per 1m of tubing	Working length EZ	Length to flexure	Max. axial misalignment
	Elastomer insert A C_T^B (Nm/rad)	Elastomer insert B C_T^B (Nm/rad)	C_T^{ZWR} (Nm/rad)	H (mm)	N (mm)	Δ Ka (mm)
5	150	350	503	25	18	1,5
10	270	825	727	34	26	2
20	1,270	2,220	1,770	46	33	4
60	3,970	5,950	6,440	63	49	4
150	6,700	14,650	11,500	73	57	4
300	11,850	20,200	24,000	86	67	4
450	27,700	40,600	73,000	99	78	4
800	41,300	90,000	389,000	125	94	4
2500	87,500	108,000	950,000	142	108	5
4500	168,500	371,500	2,200,000	181	137	5
9500	590,000	670,000	5,500,000	229	171	6

Table 2

MAXIMUM TRANSMITTABLE TORQUE BY BORE DIAMETER (Nm)

Size	Ø 6	Ø 8	Ø 12	Ø 16	Ø 19	Ø 25	Ø 30	Ø 32	Ø 35	Ø 45	Ø 50	Ø 55	Ø 60	Ø 65	Ø 70	Ø 75	Ø 80	Ø 90	Ø 120	Ø 140	
5	4	10	15																		
10	6	12	20	32																	
20		30	35	40	50	65															
60				65	120	150	180	200													
150					180	240	270	300	330												
300					300	340	450	520	570	630											
450							630	720	770	900	1120	1180	1350								
800									1050	1125	1200	1300	1400	1450	1500	1550	1600				
2500										1900	2600	2900	3200	3500	3800	4000	4300	4600	5200		
4500											5300	5800	6300	7000	7600	8200	8800	9400	10600	14100	
9500												9200	10100	11100	11900	12800	13800	14800	16700	22000	25600

TEMPERATURE FACTOR S

Temperature (°C)	A	B
	Sh 98 A	Sh 64 D
> -30° to -10°	1.5	1.7
> -10° to +30°	1.0	1.0
> +30° to +40°	1.2	1.1
> +40° to +60°	1.4	1.3
> +60° to +80°	1.7	1.5
> +80° to +100°	2.0	1.8
> +100° to +120°	-	2.4

ACCORDING TO TORSIONAL STIFFNESS

Condition: Line shaft ZA, size 150 $T_{AS} = 150$ Nm
Wanted: Total torsional stiffness $C_{T^{ZA}}$

$$(C_{T^{ZA}}) = \frac{87,500 \text{ Nm/rad} \times (24,000 \text{ Nm/rad} / 1.344 \text{ m})}{87,500 \text{ Nm/rad} + (24,000 \text{ Nm/rad} / 1.344 \text{ m})} = 14,830 \text{ [Nm/rad]}$$

$$(C_{T^{ZA}}) = \frac{C_T^B \cdot (C_T^{ZWR}/Z)}{C_T^B + (C_T^{ZWR}/Z)} \text{ (Nm/rad)}$$

ACCORDING TO TORSIONAL DEFLECTION

Condition: Line shaft ZA, size 150 $T_{AS} = 150$ Nm
Wanted: Torsional deflection at maximum acceleration torque T_{AS}

Measurement (A) of Line Shaft - 1.5m
Length (Z) of Tubing = A-(2xH) = 1.344m

$$\varphi = \frac{180 \times 150 \text{ Nm}}{\pi \times 14,830 \text{ Nm/rad}} = 0.579^\circ$$

With a maximum torque of 150 Nm the torsional deflection is 0.579°

$$\varphi = \frac{180 \cdot T_{AS}}{\pi \cdot C_T} \text{ (degree)}$$

SIZING AND SELECTION

LINE SHAFTS

ZA **EZ**

ACCORDING TO MAXIMUM MISALIGNMENT

	Lateral misalignment ΔKr	Angular misalignment ΔKw	Axial misalignment ΔKa
ZA			
EZ			
	$\Delta Kr_{max} = \tan \Delta \frac{Kw}{2} \cdot AB$ $AB = A - 2xN$	$\Delta Kw_{max} = 2^\circ$	See table 1+2 Pages 16+17

R+W CALCULATION PROGRAM

Using proprietary software, R+W will calculate the specific mechanical details of exactly the model you plan to use. Overall length, tube materials (e.g. steel, aluminum, CFK), and other factors are used to determine a number of performance values unique to your line shaft coupling.

- Critical speed
- Torsional stiffness of tubing
- Overall stiffness
- Torsional deflection
- Total Weight
- Moment of inertia
- Maximum misalignment

- n_k = 1/min.
- C_T^{ZWR} = Nm/rad
- C_T^{ZA} = Nm/rad
- φ = degree-min-sec
- m = kg
- J = kgm^2
- ΔKr = mm

DISC PACK COUPLINGS

LP

SYMBOLS

- T_{KN} = Rated torque of the coupling (Nm)
- T_{AS} = Peak torque of the drive system
e.g. max. acceleration torque of drive (Nm)
or max. braking torque of load (Nm)
- J_L = Total load inertia (e.g. spindle + slide + workpiece +
1/2 of coupling) (kgm²)
- J_A = Total driving inertia (motor [including gear ratio] +
1/2 of coupling) (kgm²)
- C_T = Torsional stiffness of the coupling (Nm/rad)
- f_e = Natural frequency of the two mass system (Hz)
- f_{er} = Excitation frequency of the drive (Hz)
- φ = Torsional deflection (degree)

Shock or Load Factor S_A		
uniform load	non-uniform load	highly dynamic load
1	2	3-4
Common factor for servo drives in machine tools: $S_A = 2-3$		

ACCORDING TO TORQUE

Couplings are normally sized for the highest torque to be regularly transmitted. The peak torque of the application should not exceed the rated torque of the coupling. The following calculation provides an approximation of the minimum required coupling size, and allows for the maximum rated speed and misalignment to exist in the application.

$$T_{KN} \cong 1.5 \cdot T_{AS} \text{ (Nm)}$$

ACCORDING TO ACCELERATION TORQUE

A more detailed calculation takes acceleration and the driving and driven moments of inertia into account. A strong inertia ratio diminishes the effect of the load factor in the sizing calculation.

$$T_{KN} \cong T_{AS} \cdot S_A \cdot \frac{J_L}{J_A + J_L} \text{ (Nm)}$$