



FOR API 610 REQUIREMENTS

350 - 20,000 Nm

ABOUT



FEATURES

- ▶ meets all requirements of API 610
- ▶ intermediate tube removable without disturbing adjacent equipment
- ▶ integral safety catch in case of disc pack rupture
- ▶ ISO G6.3 / AGMA class 9 minimum balance quality
- ▶ highly customizable

- ▶ **Hubs and spacer:** high strength steel

DESIGN

Two precision machined coupling hubs and precision spacer tube mounted to the disc packs by means of high strength screws and bushings for alignment and frictional clamping of the assembly. Axial retention with DIN 916 set screws.

MATERIAL

- ▶ **Disc packs:** highly elastic, corrosion resistant spring steel

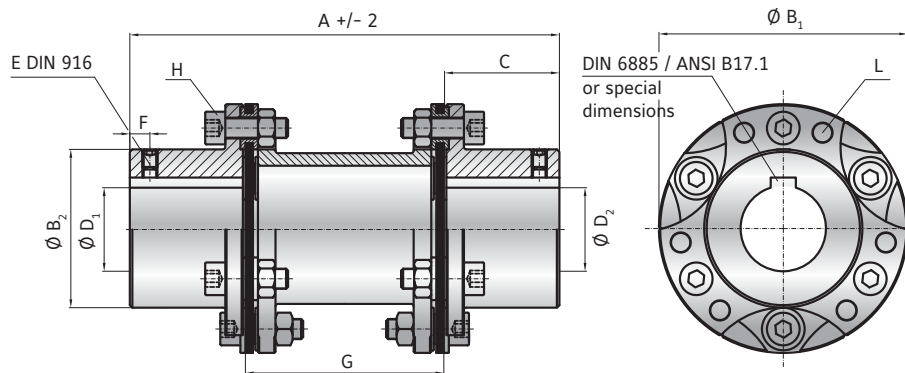

MODEL LPA

SIZE			300		700		2000		4000		7000		10000	
Rated torque (Nm)	T _{KN}		350		700		2000		4500		7600		10000	
Maximum torque (Nm)	T _{Kmax}		700		1400		4000		9000		15200		20000	
Overall length (mm)	A		190	230	250	290	330	400	360	430	380	450	500	550
Outside diameter (mm)	B ₁		104		130		160		202		248		312	
Hub diameter (mm)	B ₂		63		78		86		120		140		194	
Hub fit length (mm)	C		45		55		75		90		100		125	
Bore diameter available from Ø to Ø H7 (mm)	D _{1/2}		18 - 48		25 - 58		28 - 64		38 - 90		50 - 102		70 - 140	
Set screw (DIN 916)	E		see table (depends on bore diameter)*											
Distance to screw (mm)	F		15		15		20		20		25		30	
Distance (mm)	G		100	140	140	180	180	250	180	250	180	250	250	300
Assembly screw (ISO 4762) Nut (DIN 934)	H		M8		M10		M16		M20		M24		M24	
Tightening torque (Nm)			38		75		320		650		1000		1100	
Safety catch screws (DIN 916)	L		M6		M8		M10		M12		M16		M20	
Moment of inertia (10 ⁻³ Nm/kgm ²)			3	3.1	7.4	7.7	25	25.2	89.3	90.4	230	236	721	726
Material			steel		steel		steel		steel		steel		steel	
Approximate weight (kg)			3		4.7		11		20.7		35		68.8	
Torsional stiffness (10 ³ Nm/rad)	C _T		220		550		700		1700		2800		6200	
Axial ± (mm)			1		1.5		2		2.5		2.5		3	
Lateral ± (mm)			0.8	1	1	1.3	1.4	1.5	1.4	1.6	1.6	1.9	2.2	2.4
Angular ± (degree)			1°		1°		1°		1°		1°		1°	
Maximum speed (1/min.)			10000		8000		6000		5000		4500		4000	

Bore range Ø		Ø 18 - 30	Ø 30.1 - 44	Ø 44.1 - 65	Ø 65.1 - 85	Ø 85.1 - 110	Ø 110.1 - 140
Set screw size*		M5	M8	M10	M12	M16	M20

ORDERING EXAMPLE	LPA	700	250	42	38.1	XX
Model	●					
Size		●				
Overall length mm			●			
Bore D1 H7				●		
Bore D2 H7					●	
For custom features place an XX at the end of the part number and describe the special requirements (e.g. LPA / 700 / 250 / 42 / 38.1 / XX; XX=with puller holes)						

Special designation only (e.g. special hub for large bore).

DISC PACK COUPLINGS LP