

LP2

WITH KEYWAY MOUNTING 350 - 20,000 Nm

ABOUT

FEATURES

- ▶ high torsional stiffness
- ▶ double flex design
- ▶ customer specified length available

MATERIAL

- ▶ **Disc packs:** highly elastic spring steel
- ▶ **Hubs and spacer:** high strength steel

DESIGN

Two precision machined coupling hubs and precision spacer tube mounted to the disc packs by means of high strength screws and bushings for alignment and frictional clamping of the assembly. Axial retention with DIN 916 set screws.

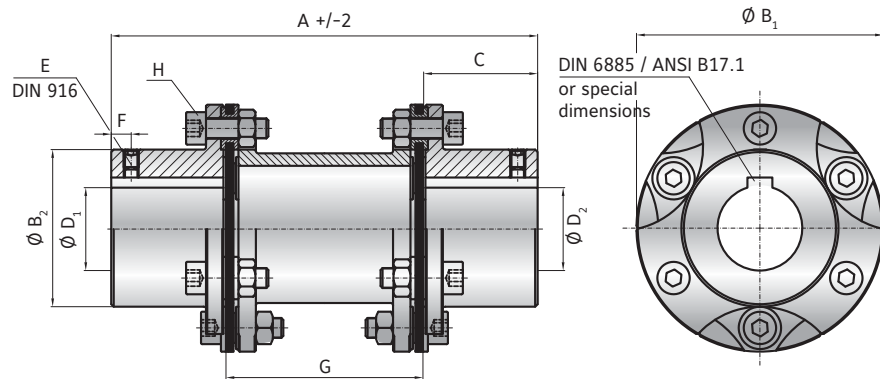

MODEL LP2

SIZE		300		700		2000		4000		7000		10000	
Rated torque (Nm)	T_{KN}	350		700		2000		4500		7600		10000	
Maximum torque (Nm)	T_{Kmax}	700		1400		4000		9000		15200		20000	
Overall length (mm)	A	170	186	206	226	286	292	320	340	370	394	470	482
Outside diameter (mm)	B_1	99		128		150		198		238		298	
Hub diameter (mm)	B_2	63		78		86		120		140		194	
Hub fit length (mm)	C	45		55		75		90		100		125	
Bore diameter available from \emptyset to \emptyset H7 (mm)	$D_{1/2}$	18 - 48		25 - 58		28 - 64		38 - 90		50 - 102		70 - 140	
Set screw (DIN 916)	E	see table (depends on bore diameter)*											
Distance to screw (mm)	F	15		15		20		20		25		30	
Distance (mm)	G	80	96	96	116	136	142	140	160	170	194	220	232
Assembly screw (ISO 4762) Nut (DIN 934)	H	M8		M10		M16		M20		M24		M24	
Tightening torque (Nm)		38		75		320		650		1000		1100	
Moment of inertia ($10^{-3}kgm^2$)	J_{ges}	3	3.1	7.4	7.7	25	25.2	89.3	90.4	230	236	721	726
Material		steel		steel		steel		steel		steel		steel	
Approximate weight (kg)		3		4.7		11		20.7		35		68.8	
Torsional stiffness ($10^3Nm/rad$)	C_T	220		550		700		1700		2800		6200	
Axial \pm (mm)		1		1.5		2		2.5		2.5		3	
Lateral \pm (mm)		0.8	1	1	1.3	1.4	1.5	1.4	1.6	1.6	1.9	2.2	2.4
Angular \pm (degree)		1°		1°		1°		1°		1°		1°	
Maximum speed (1/min.)		10000		8000		6000		5000		4500		4000	
Bore range \emptyset (mm)		\emptyset 18 - 30		\emptyset 30.1 - 44		\emptyset 44.1 - 65		\emptyset 65.1 - 85		\emptyset 85.1 - 110		\emptyset 110.1 - 140	
Set screw size*		M5		M8		M10		M12		M16		M20	

ORDERING EXAMPLE	LP2	700	206	38.1	42	XX
Model	●					
Size		●				
Overall length mm			●			
Bore D1 H7				●		
Bore D2 H7					●	
For custom features place an XX at the end of the part number and describe the special requirements (e.g. LP2 / 700 / 206 / 38.1 / 42 / XX; XX=stainless steel hubs and spacer)						

DISC PACK COUPLINGS LP