

**EK2**

# STANDARD VERSION WITH CLAMPING HUB

## 6 - 2,150 Nm

### ABOUT



#### FEATURES

- ▶ easy mounting
- ▶ highly concentric assembly
- ▶ vibration damping

#### MATERIAL

- ▶ **Hubs:** up to size 450 high strength aluminum; size 800 steel
- ▶ **Elastomer:** wear resistant thermally stable TPU

#### DESIGN

Two concentrically machined hubs with curved jaws and clamping screws. Elastomer is press fit for zero backlash; standard versions are electrically isolating.

ORDERING EXAMPLE  
see page 71

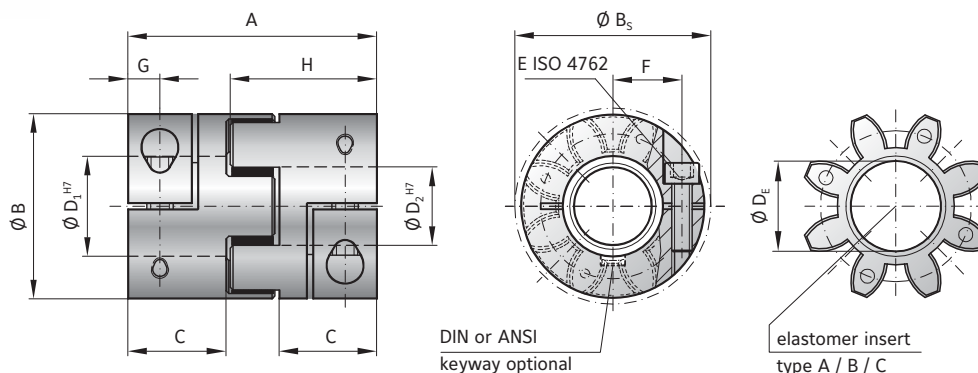

### MODEL EK2

SIZE	20			60			150			300			450			800		
Type (Elastomer insert)	A	B	C	A	B	C	A	B	C	A	B	C	A	B	C	A	B	C
Rated torque (Nm) $T_{KN}$	17	21	6	60	75	20	160	200	42	325	405	84	530	660	95	950	1100	240
Max. torque* (Nm) $T_{Kmax}$	34	42	12	120	150	35	320	400	85	650	810	170	1060	1350	190	1900	2150	400
Overall length (mm) A	66			78			90			114			126			162		
Outside diameter (mm) B	42			56			66.5			82			102			136.5		
Outside diameter with screw head (mm) $B_s$	44.5			57			68			85			105			139		
Mounting length (mm) C	25			30			35			45			50			65		
Inside diameter range H7 (mm) $D_{1/2}$	8 - 25			12 - 32			19 - 36			20 - 45			28 - 60			35 - 80		
Inside diameter of elastomer (mm) $D_e$	19.2			26.2			29.2			36.2			46.2			60.5		
Clamping screw (ISO 4762) E	M5			M6			M8			M10			M12			M16		
Tightening torque of the clamping screw (Nm)	8			15			35			70			120			290		
Distance between centers (mm) F	15.5			21			24			29			38			50.5		
Distance (mm) G	8.5			10			12			15			17.5			23		
Hub length (mm) H	39			46			52.5			66			73			93.5		
Moment of inertia per hub ( $10^{-3} \text{ kgm}^2$ ) $J_1/J_2$	0.016			0.05			0.13			0.4			0.9			9.5		
Approx. weight (kg)	0.15			0.35			0.6			1.1			1.7			10		
Speed standard ( $\text{min}^{-1}$ )	12,500			11,000			10,000			9,000			8,000			4,000		
Speed balanced ( $10^3 \text{ min}^{-1}$ )	45	60	35	31	31	25	22	26	18	22	26	16	16	17	12	13	13	8

For information on shaft misalignment, torsional stiffness, and other details about the elastomer inserts see pages 66 + 67.

\* Maximum transmittable torque of the clamping hub depends on the bore diameter

Size	Ø 8	Ø 16	Ø 19	Ø 25	Ø 30	Ø 32	Ø 35	Ø 45	Ø 50	Ø 55	Ø 60	Ø 65	Ø 70	Ø 75	Ø 80
20	20	35	45	60											
60		50	80	100	110	120									
150			120	160	180	200	220								
300			200	230	300	350	380	420							
450					420	480	510	600	660	750	850				
800							700	750	800	835	865	900	925	950	1,000

Higher torque possible with keyways

ELASTOMER  
COUPLINGS EK | TX