

BZ

OPTIONS / SPECIAL SOLUTIONS

1,900 - 2,080,000

FLEXIBLE GEAR COUPLINGS - FURTHER POSSIBILITIES

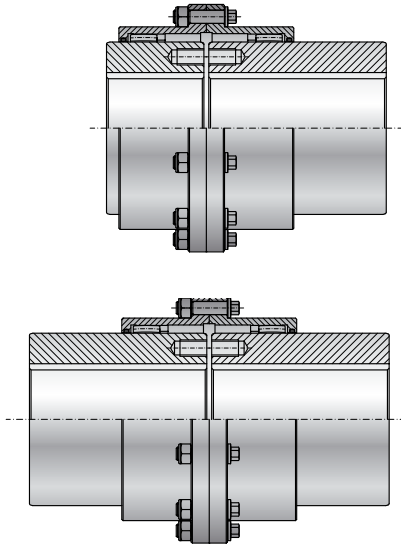

WITH EXTENDED HUB ON ONE OR BOTH ENDS

- ▶ Hub length is customizable
- ▶ Easy replacement of existing gear couplings
- ▶ Optimal utilization of available space

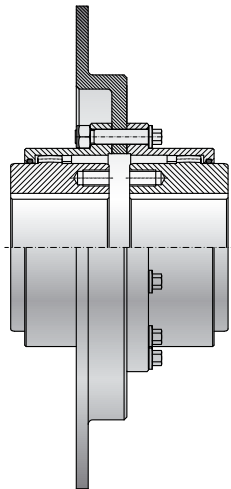

WITH BRAKE DISC

- ▶ custom dimensions available
- ▶ use for holding or emergency stopping

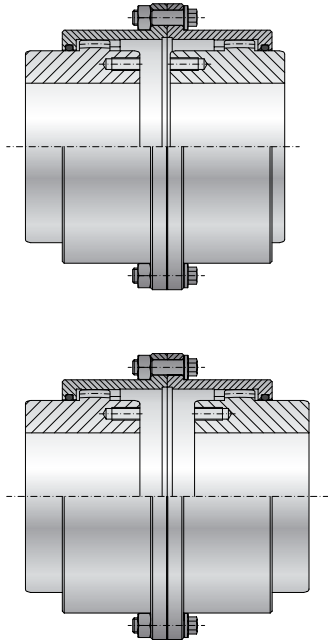

WITH REVERSED HUB ON ONE OR BOTH ENDS

- ▶ for minor increases in the distance between shaft ends
- ▶ optimized torque transfer with best shaft engagement
- ▶ longer life