

MVC₄

MEDIUM VOLTAGE SOLID STATE SOFT STARTER

New Improved Design



5kV
CLASS

7kV
CLASS

15kV
CLASS

DRIVE CENTRE 
Industrial Automation Systems Integrators

57 Galaxy Blvd., Units 1 & 2, Toronto, ON M9W 5P1
TEL: (416) 231-6767
www.drivecentre.ca

3 YEAR
WARRANTY

with factory startup



MVC4

MEDIUM VOLTAGE SOLID STATE SOFT STARTER

4th Generation Enhancements

- Intelligent PFC Controller
- Energy Efficient Green Design
- Patented Design for Extended Lead Length
- Improved Power Ride-Through
- Corona Free 15kV Design



Line Diagram

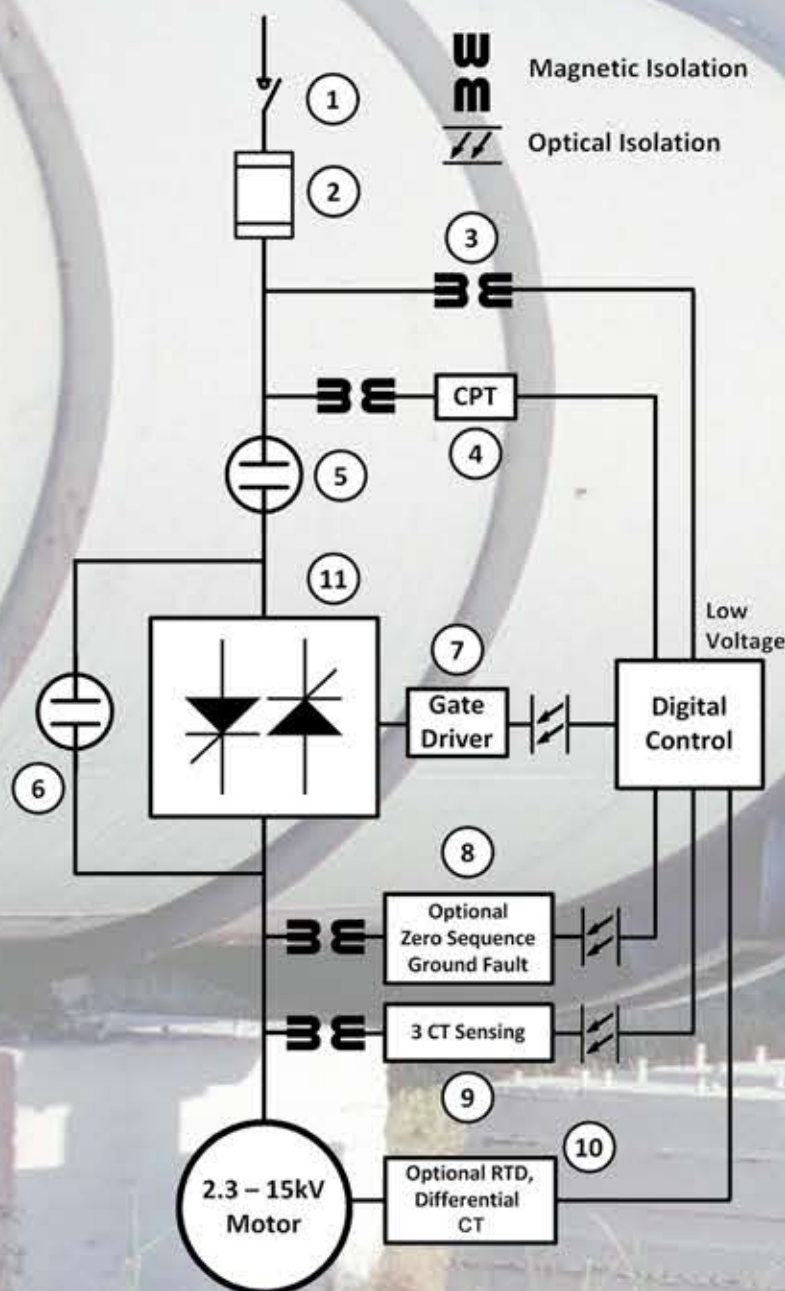

1. Load Break / Fault Make Disconnect Switch with Visible Ground Safety Bar
2. Coordinated Motor Fuse Protection
3. Magnetic Isolated PT for Voltage Sensing 60K Bil up to 7.2KV, 110K Bil up to 13.8KV
4. Control Power Transformer
5. Isolation Contactor Rated for Across the Line Start
6. Bypass Contactor Rated for Across the Line Start
7. Sustained Pulse Fiber Optical Isolated Gate Drive
8. Optional Zero Sequence Ground Fault Fiber Optically Isolated
9. Current Sensing Card Fiber Optically Isolated
10. Optional RTD, Differential CT (TE-RTD12)
11. Heavy Duty SCR Stack Assembly With Ring Transformer Sustained Pulse Firing

Complete Motor Protection

The MVC 4 Series soft starter provides the highest standard of motor control and unsurpassed protection for critical motor applications.

True Thermal Modeling

Monitors the motor for excessive thermal conditions due to starting, running and even ambient conditions.

Thermal Model Biasing

Adjusts for heating effects of phase current imbalance or optional RTD inputs.

Retentive Thermal Memory

For continuous overload protection even after a complete Power loss. When power is restored, the MVC 4 remembers the last thermal condition of the motor, observes the off time via a real-time clock and adjusts the thermal model accordingly.

Non-Volatile Memory

Stores the thermal memory without the need for batteries.

True Time Thermal Tracking

Adjusts the thermal model for different cooling rates based on motor temperature, running state or power loss.

ANSI / IEE Number	System/Protection Features	Standard
19	Reduced voltage soft start	✓
27	Under voltage	✓
37	Undercurrent	✓
46	Current imbalance	✓
47	Phase rotation	✓
48	Locked rotor / Incomplete sequence	✓
49	I ² t electronic motor overload	✓
50	Instantaneous electronic over current trip	✓
51	Over current	✓
55	Power factor trip	✓
59	Over voltage protection	✓
66	Starts per hour and time between starts	✓
81	Frequency variance	✓
86	Lockout / start inhibit	✓
50N/51G/N	Ground fault detection, instantaneous and current	Optional
49/38	Stator and bearing RTD protection	Optional
14	Speed switch and tachometer trip	Optional

Dynamic Reset Response

Reset is only allowed after the motor has sufficient thermal capacity for a successful restart.

Start any Motor any Application

Choose the acceleration ramp that is best for your application with the flexibility of microprocessor based ramp control.

Pumps, Fans, Blowers & Conveyors

Closed Loop Torque (CLT™) using PID algorithms is ideal for deep well pumps or systems where the load conditions change from one start to the next. Linear Speed Ramping can be achieved by adding a tachometer feedback signal from the motor.

Compressors & Chillers

Voltage Ramp with Current Limit for applications that need the smoothness of voltage ramping while maintaining the ability to start in limited power environments. For maximum motor power where the available power supply is severely limited, a Current Limit/Current Step start can be used.

Process Machinery

The Jog function can be used in initial machine setup. Apply just enough voltage/torque to rotate the motor shaft without accelerating to full speed. Dual ramps are built-in, allowing for different load conditions and ramping requirement.

Generator Powered & Mobile Equipment

Protect the integrity of your process even when power conditions are less than perfect. Reliable SCR firing even during frequency drift that may occur with portable equipment or backup generators.

Specialty Motor Applications

- **Synchronous Exciter**
The MVC 4 Series can be integrated with synchronous exciters in both brush and brushless packages.
- **Wound Rotor**
Apply the exact rotor resistance needed for your application, while soft starting the stator with the MVC 4.
- **Reversing or 2 speed**
Controls can be built-in, or the MVC 4 Series can be retrofitted behind existing 2 speed controllers.
- **Inching / Spotting Control**
For low speed load positioning to line up access ports, test blade positions, etc.
- **Multiple Motor**
Control and protect multiple motors from one soft starter.



Advanced Integration

The MVC 4 Series soft starter is specifically designed for ease of integration into automation systems, the MVC 4 offers communications and flexible I/O as standard.

Flexible I/O

- 120Vac control power input accepts long control circuit runs without the need for interposing relays.
- 8 programmable relay outputs for control flexibility without the need for external auxiliary relays or add-on cards.
- 2 programmable analog outputs (0 - 10Vdc or 4 - 20mA).

Communication Ready

Built-in comm ports

- RS-232 for one on one communications with a PC.
- RS-485 for multi-drop communications with Modbus RTU protocol as standard.
- Profibus, DeviceNet, EtherNet/IP, PROFINET, Modbus TCP (Communication Modules are options).

MVC Series MLink Commissioning Software

The MVC MLink Windows® based software offers users the ability to program, startup and troubleshoot the MVC Series Soft Starter via the built-in RS485 connection. The MVC Series MLink reduces startup time and allows for commissioning data to be backed up and e-mailed directly from the software. Other features Include:

- Parameter editing and commissioning
- E-mail and Export commissioning data directly from the software
- Parameter compare functions
- Parameter settings export to popular file format (PDF, XLS, RTF, etc...)
- Application Setup Wizard
- Visual Programming, point and click on visual terminal strip
- Monitor Panel with 4 programmable signals
- Trend-recorder with 6 programmable channels, storage and playback mode
- Status and Diagnostics Panel, status, fault history and event log overview
- Communication connection for serial, USB and Ethernet
- Comprehensive help and product user manual
- Multi-drop network support
- Demo modes for all interactive functions.
- Automatic Software Updates



Complete Starter Model Numbers - Class E-2 Controller

MVC4

- ESWG

Voltage	Amps.	Available for Input Voltage
10 = 1000V	100 = 100A	(2300V – 13800V)
23 = 2300V	200 = 200A	(1000V – 13800V)
33 = 3300V	320 = 320A	(13800V)
41 = 4160V	400 = 400A	(1000V – 13800V)
66 = 6600V	600 = 630A	(2300V – 11000V)
69 = 6900V	600 = 600A	(13800V)
72 = 7200V	1000 = 1000A	(2300V – 13800V)
110 = 11000V		
138 = 13800V		

Specification

The MVC 4 Series soft starter provides the highest standard of motor control and unsurpassed protection for critical motor applications.

Type of Load

3-phase medium voltage AC induction or synchronous motors

AC Supply Voltage

1000, 2300, 3300, 4160, 6000/7200V, 11-15kV
VAC +10% to -15%, 50/60 Hz line voltages

HP Ratings

Up to 10,000 HP @ 7.2kV (800 Amps)

Up to 20,000 HP @ 15kV (800 Amps)

Contact factory for higher rating requirements

Overload Rating

AC53b 600-30-60m

Power Circuits

Series strings of SCR power modules (1 to 6 pairs of SCRs per phase depending on voltage rating)

SCR Peak Inverse Voltage

Line Voltage	PIV Rating	Line Voltage	PIV Rating
1000	4500	6600	14500
2300	6600	6900-7200	26000
3300	9000	11000	27000
4160	13000	13-15kV	39000
6000	18000		

BIL Rating

1000V: 30kV

2300V - 7200V: 60kV

11000 - 15000V: 110kV

Transient Voltage Protection

dv/dt circuits (1 per SCR pair)

Vacuum Bypass Contactor

Standard on all models, line start rated

Ambient Operating Conditions

0 - 50°C (82° F to 122° F) (Optional -20° to 50° C with heaters)

5 - 95% relative humidity

0 - 3300 ft (1000m above sea level without derating)

Digital Control Unit (DCU)

Programmable keypad/operator with 2 lines x 20 character backlit LCD display. Status/Alarm LEDs (indicate: Power, Run, Alarm, Trip, Aux 1 - 8)

Differential Protection

TE-RTD12 for Differential Protection

Auxiliary Contacts

Multiple Form C contacts rated 5A @ 250VAC max.

6 fully programmable relays (including fail-safe operation)

5 dedicated relays (fault, at-speed, etc.)

Programmable Features

Motor FLA, service factor, insulation class

Dual Ramp Adjustments - Two independent settings for:

- Initial Torque 0 - 100% of nominal torque, voltage or current

- Current Limit 200 - 600% of motor FLA

- Acceleration Time 1 - 120 seconds

Power Ramp Function

Three Custom Curves Via plotted torque/time axis points

Pump-Flex™ Decel 1 - 60 seconds with begin & end torque adj

Kick Start 0.1 - 2.0 seconds (10 - 100% voltage)

Tach Feedback (option) Closed loop speed ramp

Motor and Starter Protection

Electronic Overload

Phase Loss

Phase Imbalance

Phase Reversal

Short Circuit Detection

Over / Under Current

Over / Under Voltage

Shorted SCR / Shunt Trip

Starter Over-Temp

Coast Down Lockout

Starts per Hour Lockout

Time between starts

RTD Input (Option)

Ground Fault (Option)

Statistical Data

Elapsed run time, last start time, average starting current, stores history of up to 60 events (data includes date & time, phase & ground fault current). Also displays time-to-trip, remaining inhibit time and starts/hour values.

Metering (Voltage & Current)

Percent of FLA, phase currents, kVAR, kVA, kW, power factor, demand, avg. start current, remaining thermal register, thermal capacity to start, measured capacity to start, time since last start, line frequency, phase order, RTD values (optional)

Enclosure

NEMA 12 with 3R optional (not for direct sun applications), top and bottom entrance plates, 11 gauge steel, ASA #61 gray powder coated paint.

CORPORATE HEADQUARTERS

Motortronics / Phasetronics

1600 Sunshine Drive

Clearwater, Florida 33765

Tel: 727.573.1819 or 888.767.7792

Fax: 727.573.1803 or 800.548.4104

E-mail: sales@motortronics.com

www.motortronics.com

INTERNATIONAL LOCATIONS

Motortronics Int'l Korea Co Ltd

601, Daeryung Techno Tower 5-cha

Gasan-dong, Geumcheon-gu

Seoul, Korea 9153-774

Tel: 82-2-867-5808 / Fax: 82-2-867-6004

www.motortronics-korea.com



MOTORTRONICS™

Solid State AC Motor Control

M & P Machinery & Electronics Control

113 Zaoshan Road

Qingdao, China 266100

Tel: 86-532-87660633

Fax: 86-532-87660733

www.mp-cn.com

PN: MVC4-071514