



LINEATOR™ Advanced Universal Harmonic Filter for VFD's Questions and Answers

This document has been written to provide answers to the more frequently asked questions we have received regarding the application of the LINEATOR™ Advanced Universal Harmonic Filter on Variable Frequency Drives (VFD's). This information will be of interest to both those experienced in treatment of harmonics generated by VFD's and those new to the problem of harmonics. For additional information visit our Website at <http://www.mirusinternational.com>.

1. [What are non-linear loads and why are they a concern today?](#)
2. [Do different types of non-linear loads generate different harmonics?](#)
3. [Why do non-linear loads have low power factors and why is it important to have a high power factor?](#)
4. [What is a Variable Frequency Drive and how does it generate harmonics?](#)
5. [What problems do non-linear loads and harmonics create?](#)
6. [How do non-linear loads create current and voltage harmonics?](#)
7. [What ill effects do the harmonics created by VFD's have on themselves?](#)
8. [What is IEEE Std 519 and how does it apply to VFD installations?](#)
9. [What is the LINEATOR™ AUHF and how does it treat VFD harmonics?](#)
10. [How is the LINEATOR™ different than other forms of passive harmonic filters?](#)
11. [What other forms of harmonic treatment are available for VFD's?](#)
12. [How does the LINEATOR™ compare to a 12-Pulse or 18-Pulse VFD?](#)
13. [Is the LINEATOR™ compatible with all VFD's?](#)
14. [Is the LINEATOR™ suitable for generator applications?](#)
15. [What if my VFD is equipped with a by-pass?](#)
16. [Can I use a single LINEATOR to supply multiple VFD's?](#)
17. [Can I get a computer simulation to demonstrate compliance with IEEE Std 519 or simply to show the LINEATOR™'s effectiveness in a specific application?](#)
18. [What kind of performance guarantee does the LINEATOR™ have?](#)
19. [What information is required to properly apply the LINEATOR™ AUHF?](#)

DRIVE CENTRE 
Industrial Automation Systems Integrators

57 Galaxy Blvd., Units 1 & 2, Toronto, ON M9W 5P1
TEL: (416) 231-6767
www.drivecentre.ca

[<Back to Questions>](#)

1. What are non-linear loads and why are they a concern today?

A load is considered non-linear if its impedance changes with the applied voltage. The changing impedance means that the current drawn by the non-linear load will not be sinusoidal even when it is connected to a sinusoidal voltage. These non-sinusoidal currents contain harmonic currents that interact with the impedance of the power distribution system to create voltage distortion that can affect both the distribution system equipment and the loads connected to it.

In the past, non-linear loads were primarily found in heavy industrial applications such as arc furnaces, large variable speed drives, heavy rectifiers for electrolytic refining, etc. The harmonics they generated were typically localized and often addressed by knowledgeable experts.

Times have changed. Harmonic problems are now common in not only industrial applications but in commercial buildings as well. This is due primarily to new power conversion technologies, such as the Switch-mode Power Supply (SMPS), which can be found in virtually every power electronic device (computers, servers, monitors, printers, photocopiers, telecom systems, broadcasting equipment, banking machines, etc.). Another major influence is the more widespread use of variable frequency drives in commercial HVAC applications (chillers and fans) and industrial pumping (oil and gas, water/waste water, etc.). Their proliferation has made non-linear loads a substantial portion of the total load in most commercial buildings as well as industrial facilities.

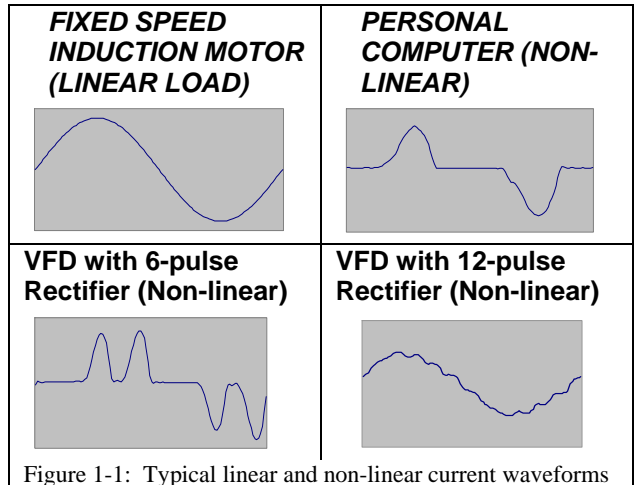

Figure 1-1: Typical linear and non-linear current waveforms

Examples of the current drawn by various types of equipment are shown in Figure 1-1. The most common form of distorted current is a pulse waveform with a high crest factor. The VFD is one such load since it consists of a 6-pulse rectifier bridge (to convert AC to DC) and a large filter capacitor on its DC bus. The VFD draws current in short, high-amplitude pulses that occur right at the positive and negative peaks of the 3-phase supply voltage. Typically these high current pulses will cause clipping or flat-topping of the voltage waveform. Further discussions on voltage flat-topping and its effect on connected equipment can be found in answers to Questions 6 and 7.

[<Back to Questions>](#)

2. Do different types of non-linear loads generate different harmonics?

By far the majority of today’s non-linear loads are rectifiers with DC smoothing capacitors. These rectifiers typically come in 3 types – (i) single phase, line-to-neutral, (ii) single phase, phase-to-phase and (iii) three-phase.

Single-phase line-to-neutral rectifier loads, such as switch-mode power supplies in computer equipment, generate current harmonics 3rd, 5th, 7th, 9th and higher. The 3rd will be the most predominant and typically the most troublesome. 3rd, 9th and other odd multiples of the 3rd harmonic are often referred to as triplen harmonics and because they add arithmetically in the neutral are also considered zero sequence currents. Line-to-neutral non-linear loads can be found in computer data centers, telecom rooms, broadcasting studios, schools, financial institutions, etc.

208V single-phase rectifier loads can also produce 3rd, 5th, 7th, 9th and higher harmonic currents but if they are reasonably balanced across the 3 phases, the amplitude of 3rd and 9th will be small. Because they are connected line-line, these loads cannot contribute to the neutral current. The largest current and voltage harmonics will generally be the 5th followed by the 7th. Typical single phase, 208V rectifier loads include the switch-mode power supplies in computer equipment and peripherals.

Three-phase rectifier loads are inherently balanced and therefore generally produce very little 3rd and 9th harmonic currents unless their voltage supply is unbalanced. Their principle harmonics are the 5th and 7th with 11th and 13th also present. They cannot produce neutral current because they are not connected to the neutral conductor. The rectifiers of variable speed drives and Uninterruptible Power Supplies (UPS) are typical examples of three-phase rectifier loads.

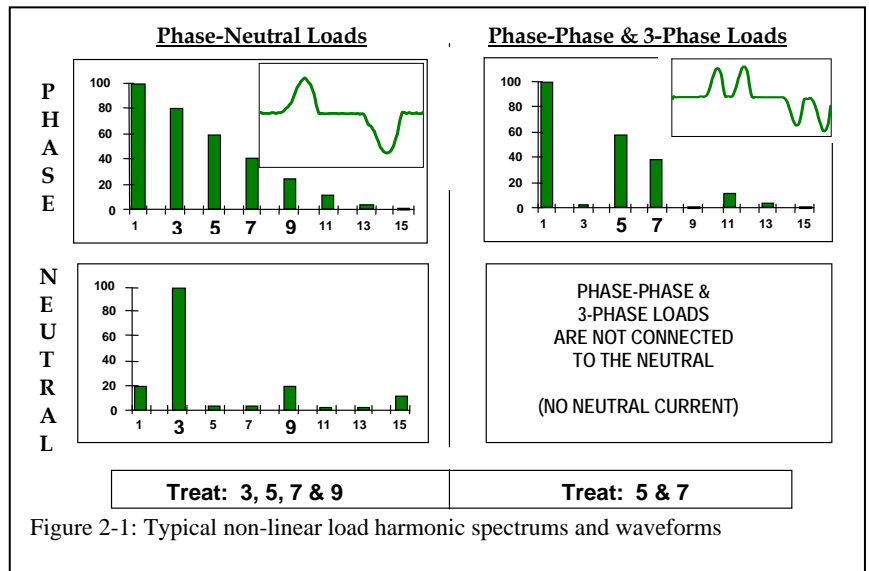

Figure 2-1: Typical non-linear load harmonic spectrums and waveforms

[<Back to Questions>](#)

3. Why do non-linear loads have low power factors and why is it important to have a high power factor?

Power factor is a measure of how effectively a specific load consumes electricity to produce work. The higher the power factor, the more work produced for a given voltage and current. Figure 3-1 shows the power vector relationships for both linear and non-linear loads. Power factor is always measured as the ratio between real power in kilowatts (kW) and apparent power in kilovoltamperes (kVA).

For linear loads, the apparent power in kVA ($S = V \cdot I$) is the vector sum of the reactive power in kVAR (Q) and the real power in kW (P). The power factor is $P/S = \cos\Phi$, where Φ is the angle between S and P. This angle is the same as the displacement angle between the voltage and the current for linear loads. For a given amount of current, increasing the displacement angle will increase Q, decrease P, and lower the PF. Inductive loads such as induction motors cause their current to lag the voltage, capacitors cause their current to lead the voltage, and purely resistive loads draw their current in-phase with the voltage. For circuits with strictly linear loads (a rare situation) simple capacitor banks may be added to the system to improve a lagging power factor due to induction motors or other lagging loads.

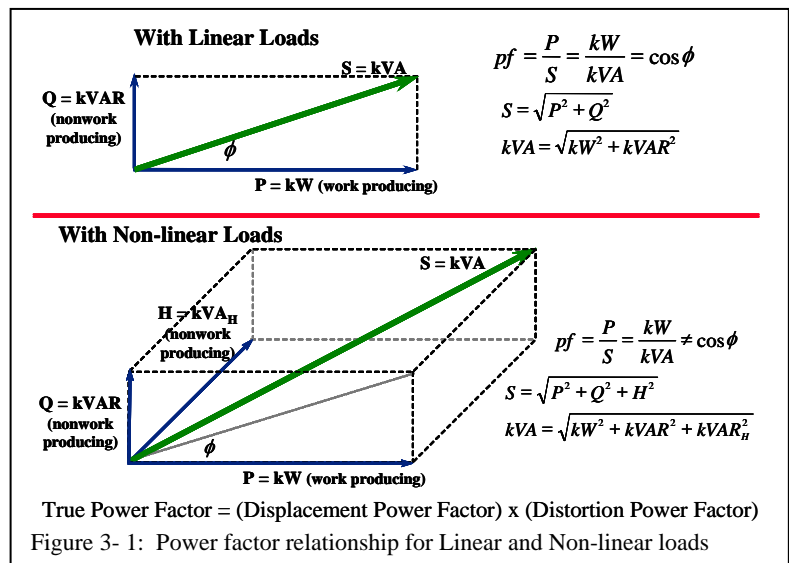

For non-linear loads, the harmonic currents they draw produce no useful work and therefore are reactive in nature. The power vector relationship becomes 3 dimensional with distortion reactive power, H, combining with both Q and P to produce the apparent power which the power system must deliver. Power factor remains the ratio of kW to kVA but the kVA now has a harmonic component as well. True power factor becomes the combination of displacement power factor and distortion power factor. For most typical non-linear loads, the displacement power factor will be near unity. True power factor however, is normally very low because of the distortion component. For example, the displacement power factor of a 6-Pulse VFD without a reactor will be near unity but its total power factor is often in the 0.65 – 0.7 range. The best way to improve a poor power factor caused by non-linear loads is to remove the harmonic currents.

Most Utilities charge their customers for energy supplied in kilowatt-hours during the billing period plus a demand charge for that period. The demand charge is based upon the peak load during the period. The demand charge is applied by the utility because it must provide equipment large enough for the peak load even though the customer's average power may be much lower. If the power factor during the peak period (usually a 10 minute sliding window) is lower than required by the utility (usually 0.9 or 0.95), the utility may also apply a low PF penalty charge as part of the demand charge portion of the bill.

Suppose the peak demand was 800kW with apparent power consumption of 1000kVA (a PF of 0.8). If a power factor penalty was applied at 0.9, the utility would charge the customer as if his demand was 0.9 x 1000kVA = 900kW even though his peak was really 800kW, a penalty of 100kW. Improving the power factor to 0.85 at 1000kVA demand would lower the penalty to just 50kW. For power factors of 0.9 to 1.0, there would be no penalty and the demand charge would be based upon the actual peak kW. The demand charge is often a substantial part of the customer's overall power bill, so it is worthwhile to maintain good power factor during peak loading and reducing the harmonic current as drawn by the loads can help achieve this.

References:

1. Roger C. Dugan, *Electrical Power Systems Quality*, McGraw-Hill, New York NY, 1996, pp. 130-133
2. H. Rissik, *The Fundamental Theory of Arc Convertors*, Chapman and Hall, London, 1939, pp 85-97

[<Back to Questions>](#)

4. What is a Variable Frequency Drive and how does it generate harmonics?

A Variable Frequency Drive (VFD) is a solid state device that converts utility power to a variable voltage and frequency in order to control the speed of a 3-phase induction motor. By controlling the motor's speed, both energy savings and better motor control can be achieved.

Figure 4.1 shows a typical VFD schematic diagram. The front-end rectifier and its DC bus smoothing capacitors make the VFD a non-linear load since it will draw current in a non-sinusoidal manner.

The characteristic harmonics generated by a diode bridge rectifier will follow the relationship below:

$$h = np \pm 1, \text{ where: } h = \text{the harmonic number}$$

$$n = \text{any integer}$$

$$p = \text{the pulse number of the rectifier}$$

Most VFD's use a 3-phase, 6-pulse ($p = 6$) rectifier which results in currents of harmonic number 5, 7, 11, 13, 17, 19, etc. being generated. When dual rectifiers are used and phase shifted by 30° a 12-pulse scheme is created. 12-pulse VFD's will only have residual amounts of 5th and 7th harmonics since substituting $p = 12$ in the above equation results in harmonics 11, 13, 23, 25, etc. Other multipulse schemes such as 18 and 24 can be used to reduce harmonics further.

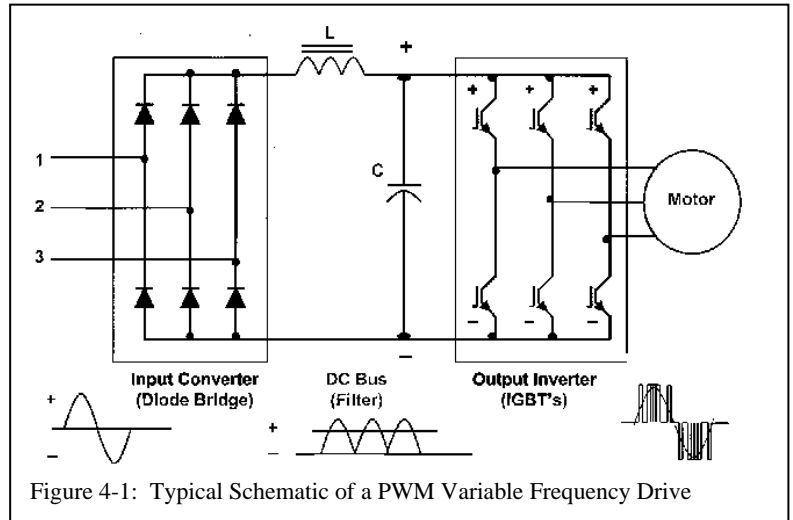

Figure 4-1: Typical Schematic of a PWM Variable Frequency Drive

[<Back to Questions>](#)

5. What problems do non-linear loads and harmonics create?

Most power systems can accommodate a certain level of harmonic currents but will experience problems when they become a significant component of the overall load. As these higher frequency harmonic currents flow through the power system, they can create problems such as:

- Overheating of electrical distribution equipment, such as cables, transformers, standby generators, etc.
- Overheating of rotating equipment, such as electric motors
- High voltages and circulating currents caused by harmonic resonance
- Equipment malfunctions due to excessive voltage distortion
- Increased internal losses in connected equipment resulting in component failure and shortened lifespan
- False operation of protection equipment
- Metering errors
- Lower system power factor preventing effective utilization
- Voltage regulator problems on diesel generators
- Inability of automatic transfer switches to operate in closed transition

Harmonics overheat equipment by several means. For example, in electric machines and transformers, harmonic currents cause additional power losses by (i) increasing the eddy currents that flow in their laminated cores, (ii) through increased leakage currents across insulation and (iii) by producing skin effect in conductors

The fact that harmonic currents create voltage distortion as they flow through the power system's impedance makes their impact even more serious. It is voltage distortion, not current distortion, that will affect the connected equipment on the power system. For more on how non-linear loads create voltage distortion and how this can affect connected equipment, see Questions 6.

[<Back to Questions>](#)

6. How do non-linear loads create current and voltage harmonics?

The front-end rectifier of a VFD is an excellent example of a non-linear load. Because it draws current in non-sinusoidal pulses, the VFD is a significant generator of harmonic currents. When found in high densities VFD's can be a major contributor to voltage distortion. The pulsed current of a 3-phase diode bridge rectifier will produce voltage distortion in the form of flat-topping. Since current is consumed only at the peak of the voltage waveform (to charge the smoothing capacitor), voltage drop due to system impedance will also occur only at the peak of the voltage waveform. A flattened voltage peak will reduce the DC bus voltage of the VFD, reduce its power disturbance ride-through capability, and increase both its current draw and I²R losses.

Another way to analyze the operation of the system with non-linear loads is to calculate the effect of each individual harmonic current as it flows through the various impedances of the distribution system. Fourier analysis tells us that the 6-pulse current drawn by the VFD's rectifier has a fundamental frequency component plus odd harmonics which include the 5th, 7th, 11th and 13th. When modeling the distribution system, we can think of each VFD as a generator of harmonic currents. Each harmonic current injected into the power system by a non-linear load will flow through the system impedance, resulting in a voltage drop at that harmonic frequency. The amount of voltage drop follows Ohm's Law (V_h = I_h x Z_h) where:

- V_h = voltage at harmonic number h
- I_h = amplitude of current harmonic h
- Z_h = impedance of the system to harmonic h.

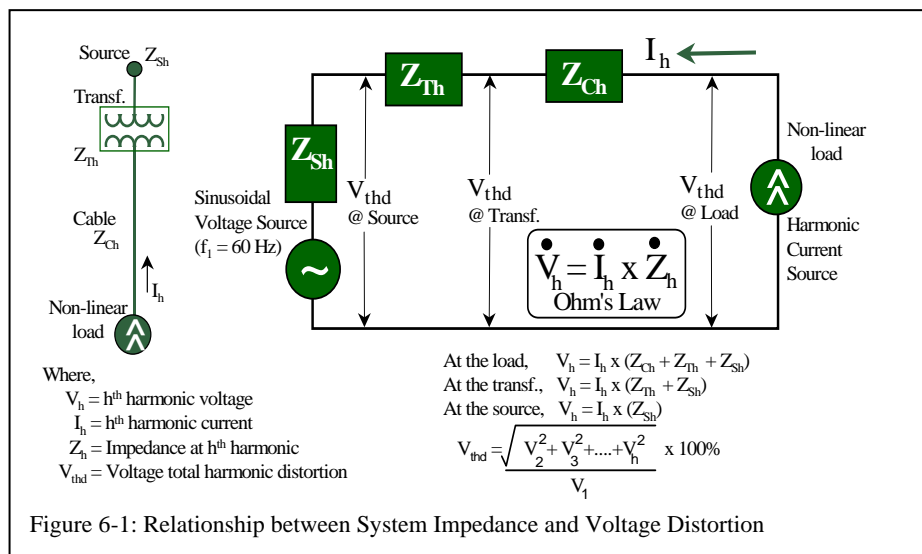

Figure 6-1 shows the relationship between system impedance and the voltage and current distortion components at several points in a typical power system.

We can calculate the RMS value of the voltage or current distortion if we know the RMS values of all of the components. Parseval's Theorem tells us that the RMS value of a waveform is equal to the square root of the sum of the squares of the RMS values of the fundamental component and all of the harmonic components of the waveform.

The fundamental is not a distortion component, so the RMS value of the distortion is just the square root of the sum of the squares of the harmonic components. Usually this is expressed as percentage of the value of the fundamental component and is called the *Total Harmonic Distortion*, or *THD*.

Voltage total harmonic distortion (V_{thd}) is calculated as:

$$V_{thd} = \frac{\sqrt{V_2^2 + V_3^2 + V_4^2 + V_5^2 + \dots}}{V_1} \times 100\%$$

Similarly, current total harmonic distortion is calculated as:

$$I_{thd} = \frac{\sqrt{I_2^2 + I_3^2 + I_4^2 + I_5^2 + \dots}}{I_1} \times 100\%$$

Voltage distortion then is a function of both the system impedance and the amount of harmonic current in the system. The higher the system impedance (ie. long cable runs, high impedance transformers, the use of diesel generators or other weak sources) the higher the voltage distortion.

In Figure 6-1, we see that voltage distortion is greatest at the loads themselves, since the harmonic currents are subjected to the full system impedance (cables, transformer and source) at that point. This is a characteristic most often misunderstood. It means that even if voltage distortion levels are low at the service entrance, they can be unacceptably high at the loads themselves. It also emphasizes the importance of keeping system impedances relatively low when servicing non-linear loads.

Voltage distortion can be minimized by removing the harmonic currents (I_h) and/or lowering the system impedance (Z_h) to the harmonics. (For further information on the relationship between voltage drop and voltage distortion and how to minimize them, we recommend two MIRUS technical papers titled (1) *'Taming the Rogue Wave – Techniques for Reducing Harmonic Distortion'* and (2) *'How the Harmonic Mitigating Transformer Outperforms the K-Rated Transformer'*).

7. What ill effects do harmonics created by VFD's have on themselves and the motor they supply?

Typical voltage distortion in the form of a severely flat-topped voltage waveform will translate to a lower DC bus voltage within the VFD. A lower DC voltage will prevent the inverter section of the VFD from generating a full rms AC voltage to the motor. When running near full load, a motor starved for voltage will draw more than its rated current, overheat and be prone to failure.

In addition, commutation notching/overvoltages caused by the operation of thyristor bridge rectifiers (or SCR's) in DC Drives or similar loads, have been known to cause AC Drive shutdowns and failures. Figure 7.1 shows voltage distortion on an off-shore oil platform with DC Drives. The severe voltage notching and overvoltages caused AC Drive failures until they were protected by LINEATOR™ AUHF's.

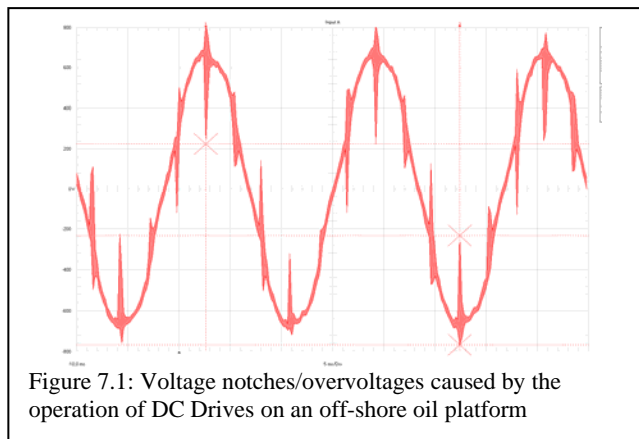

[<Back to Questions>](#)

8. What is IEEE Std 519 and how does it apply to VFD installations?

IEEE Std 519 was first introduced in 1981 as 'Recommended Practices and Requirements for Harmonic Control in Electrical Power Systems'. Most recently revised in 1992, it provides direction on dealing with harmonics introduced by static power converters and other nonlinear loads so that power quality problems can be averted. It is being applied by consulting engineers and enforced by Utilities more frequently in recent years as the use of Variable Frequency Drives and other non-linear loads has grown.

Although IEEE Std 519 can be useful for ensuring that VFD harmonics are controlled for trouble-free operation, it can be a somewhat difficult standard to apply. Two reasons for this are that it can be difficult to determine an appropriate point of common coupling (PCC) and to establish a demand current at the design stage. This is because the standard does not provide a very clear definition for PCC and the recommended definition of demand current is a value that can only be determined by measurements taken after installation. For one interpretation of how to apply IEEE Std 519 see the reference paper below.

In most VFD applications, it is difficult to meet the harmonic limits defined in IEEE Std 519 without some form of harmonic treatment. A minimum requirement is an AC line reactor or DC link choke but usually this simple form of treatment falls short of compliance. Often engineers will specify multipulse VFD's (typically 12 or 18-pulse) but these can be expensive, bulky and less efficient options. Combining a LINEATOR™ Advanced Universal Harmonic Filter with a standard 6-pulse VFD can be a very effective method of meeting IEEE Std 519 harmonic limits.

Reference:

1. A. Hoevenaars, K. LeDoux, M. Colosino, 'Interpreting IEEE Std 519 and Meeting Its Harmonic Limits in VFD Applications', PCIC-2003-15, PCIC 2003 Conference Proceedings, pp 145-150.

9. What is the LINEATOR™ AUHF and how does it treat VFD harmonics?

The LINEATOR™ a purely passive device consisting of a revolutionary new inductor combined with a relatively small capacitor bank. Its innovative design achieves cancellation of all the major harmonic currents generated by VFD's and other similar 3-phase, 6-pulse rectifier loads. By reducing current harmonic distortion to < 8% and often as low as 5%, the LINEATOR™ matches 18-Pulse VFD performance in a smaller footprint, at lower cost and with higher efficiency.

[<Back to Questions>](#)

10. How is the LINEATOR™ different from other forms of passive harmonic filters?

Although a truly passive filter, the LINEATOR™ exhibits none of the problems that plague conventional filters. The unique winding configuration of the LINEATOR™ reactor provides much better attenuation of harmonics than standard reactors thereby allowing the LINEATOR™ to get exceptional performance even with a much smaller capacitor bank than found in all other passive filters.

The large capacitor banks in both trap filters and broadband filters present a capacitive reactance to the system, especially under light loads. This can be a beneficial feature where inductive loads require a compensating reactance to improve a low displacement power factor. However, in many VFD applications, displacement power factor is quite high even though overall power factor is low due to the harmonic content. Compensation for inductive loads is not necessary and, in fact, can cause problems especially when the supply is an emergency standby generator. To address this, more sophisticated filters will be equipped with a mechanism for switching out the capacitors under light loads, increasing cost and complexity. Even under no load conditions, the capacitive reactance of the LINEATOR™ is so low that switching out the capacitors is unnecessary.

The conventional trap filter has no directional properties. It therefore, can easily be overloaded by attracting harmonics from upstream non-linear loads. The LINEATOR™, on the other hand, will present a high impedance to line side harmonics eliminating the possibility of inadvertent importation and overloading.

At frequencies below its tuned frequency, a conventional filter will appear capacitive. This capacitance has the potential of resonating with the power systems natural inductance. When a filter is tuned to a higher order harmonic, such as the 11th, it can easily resonate at a lower harmonic frequency, such as the 5th or 7th. The natural resonance frequency of the LINEATOR™ is below that of any predominant harmonic, therefore inadvertent resonance is avoided.

The filtering effectiveness of a trap filter is dependent upon the amount of harmonics present at untuned frequencies as well as the residual at the tuned frequency. To obtain performance better than 15% THID, multiple tuned branches are often required. Some broadband filters claim < 12% THID but require relatively large capacitor banks to achieve this. Even larger capacitors are required if further reduction in THID is desired. The LINEATOR™ will reduce current distortion to < 8% over the entire operating range and typically achieves near 5% THID at normal operating levels.

[<Back to Questions>](#)

11. What other forms of harmonic treatment are available for VFDs?

There are various methods presently available for treatment of VFD harmonics. Each has its advantages and disadvantages but none can achieve the price/performance level of the LINEATOR™.

Reactors and chokes are a relatively low cost solution but are only moderately effective and their high impedance can introduce trouble-some voltage drops.

Conventional tuned or trap filters, as their name implies, require tuning to a specific harmonic frequency. Their effectiveness is marginal unless multiple tuned elements are incorporated. Also, they are prone to problems such as resonance with other system components, importation of harmonics from upstream non-linear loads and a leading power factor.

By treating a wider spectrum of harmonics, broad-band filters are more effective than tuned filters but can also be more expensive. Although they address some of the issues associated with tuned filters, they are not trouble-free. Specifically, their large series inductor necessitates the use of a large capacitor bank to compensate for the voltage drop. These capacitors create a leading power factor which has been known to cause excitation control problems with generators.

	REACTOR	TUNED FILTER	LOW-PASS FILTER	MULTI PULSED	PHASE SHIFTING	ACTIVE FILTER	LINEATOR AUHF
Current Distortion	< 35%	< 15%	< 12%	< 12%	< 15%	< 5%	< 8%
Effective without Multiple Loads	Yes	Yes	Yes	Yes	No	Yes	Yes
Meets IEEE 519	Rarely	Maybe	Maybe	Maybe	Maybe	Yes	Yes
Attracting Upstream Harmonics	No	Yes	No	No	No	No	No
Engine Generator Compatibility	Partial	No	No	Yes	Yes	Yes	Yes
Inherent Transient Suppression	Yes	No	Yes	No	No	No	Yes
Efficiency	High	Moderate	Moderate	Moderate	Moderate to High	Low	High
Reduction in TIF Factor	Moderate	Moderate	High	Moderate	Moderate	High	High
Physical Size	Small	Large	Large	Very Large	Moderate to Large	Very Large	Moderate
Connection	Series	Parallel	Series	Series	Series	Parallel	Series
Price	Low	Moderate to High	High	High	Low to moderate	Very High	Moderate

Figure 11-1: Comparison Table of Various Forms of Harmonic Treatment for VFD's

In multi-pulsed systems, the drive manufacturer will phase shift between multiple front-end rectifiers to cancel harmonics. Some 18 and 24 pulsed systems can achieve Total Harmonic Current Distortion (THID) of < 8%, but they require a larger footprint and can become quite expensive.

Phase shifting transformers can be a very cost effective method of harmonic treatment but require multiple 6-pulse rectifier loads operating simultaneously. A quasi 12-pulse scheme (ie. cancellation of 5th & 7th harmonics) can be created by phase shifting one VFD against a second similar VFD. 18 and 24 pulse schemes require three and four VFD's respectively.

Active filters treat harmonics by measuring the level of harmonic current present in the system and injecting currents of opposite polarity to cancel them. Excellent performance can be achieved but reliability is sometimes an issue and their high cost normally makes their use prohibitive.

Table 11-1 provides a comparison of the various forms of VFD harmonic treatment for different parameters.

[<Back to Questions>](#)

12. How does the LINEATOR™ compare to a 12-Pulse or 18-Pulse VFD?

12 and 18-Pulse VFD's use phase shifting transformers and multiple bridges to reduce the current harmonics generated by the VFD. Under balanced voltage conditions, 12-Pulse VFD's can typically achieve current total harmonic distortion levels at full load in the 12% to 15% range while 18-Pulse VFD's can achieve 5% to 8%. Performance will degrade however when the applied voltages are even slightly unbalanced. In addition, the relatively high losses in the phase shifting transformers required for a multi-pulse application will lower the efficiency of the entire VFD package.

The LINEATOR™ applied to a 6-Pulse VFD, on the other hand, will match the performance of the 18-Pulse VFD in reducing current distortion while maintaining high efficiencies. Figures 12-1, 12-2 and 12-3 provide a comparison between a typical 18-Pulse VFD and a LINEATOR™ / 6-Pulse VFD combination. To ensure that a fair comparison was made, the identical 6-Pulse VFD module that was used in the 18-Pulse VFD was also used with the LINEATOR™ as well.

Although the 18-Pulse VFD solution and the LINEATOR™/6-Pulse combination compared favourably with respect to their ability to reduce input current distortion under balanced voltage conditions, the LINEATOR™/6-Pulse combination outperformed the 18-Pulse in many other areas.

Figure 12-1 shows the current distortion measurements with both well balanced and 1% imbalanced supply voltages. The LINEATOR™ / 6-Pulse maintained its excellent performance even with the voltage imbalance of 1%. The 18-Pulse solution had very good performance with a well balanced 3-phase supply but was much less effective with the higher voltage imbalance. Since a slight voltage imbalance is not unusual, the 18-Pulse solution will not always be able to guarantee good performance.

The advantages of the LINEATOR™/6-Pulse are even more evident when a comparison of efficiencies is observed. The LINEATOR™ / 6-Pulse combination achieved efficiencies that were 2% - 3% points higher than the 18-Pulse across the entire operating range. This would translate into very substantial energy savings and an improved payback for the installation.

The VFD's DC bus voltage level is another interesting comparison. At light loads, the capacitors within the LINEATOR™ will tend to boost the VFD's DC bus voltage slightly. The unique reactor design of the LINEATOR™ allows it to achieve its excellent performance while minimizing this voltage boost to 5% or less.

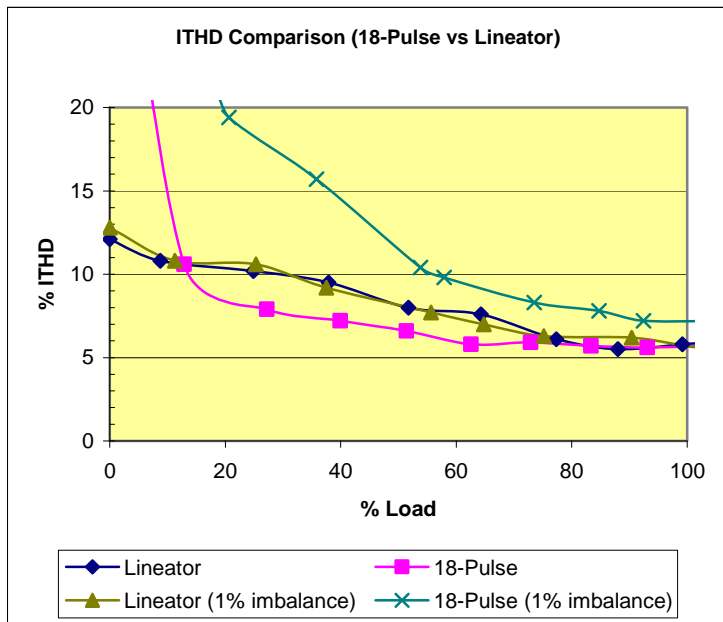

Figure 12-1: Input Current Distortion comparison – 18-Pulse vs

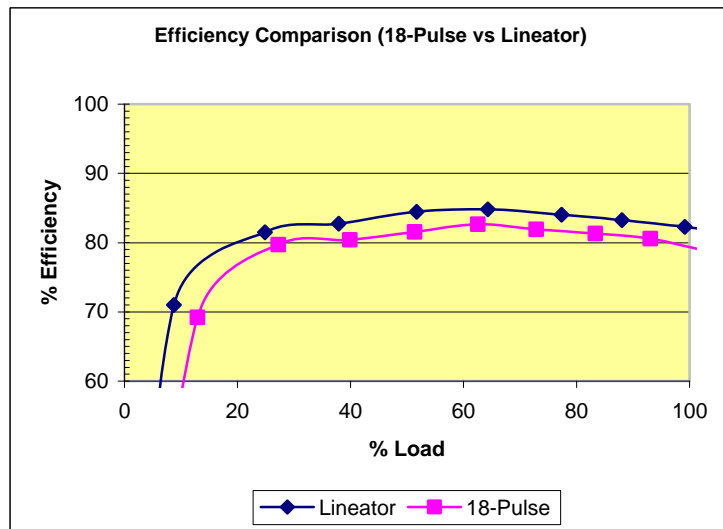

Figure 12-2: Efficiency comparison – 18-Pulse vs LINEATOR™/6-Pulse combination

[<Back to Questions>](#)

What is arguably more important is the DC bus voltage drop at full load. Any impedance added to reduce input current distortion will introduce a voltage drop as the VFD is loaded. Even a 5% AC line reactor will introduce a 5% voltage drop when operated at full load. As the voltage drops, the motor will have to draw more current in order to deliver the power required for the application. As current increases the losses in the motor will increase proportional to the square of this current. The motor will run much hotter and could be susceptible to overheating and pre-mature failure.

As shown in Figure 12-3, the 18-Pulse VFD introduced more than an 8% DC bus voltage drop at full load. This is due to the fact that the 18-Pulse solution requires significantly more impedance to reach the performance level of the LINEATOR™. The total impedance includes the phase shifting transformer, reactors to prevent cross-commutation, an AC reactor ahead of the phase shifting transformer and the AC line reactor within the VFD itself. The impedance of the LINEATOR™ is a combination of the reactor and capacitors resulting in much lower through impedance presented to the VFD. The high number of inductive components in the 18-Pulse VFD also explains why the losses are much higher and efficiency lower.

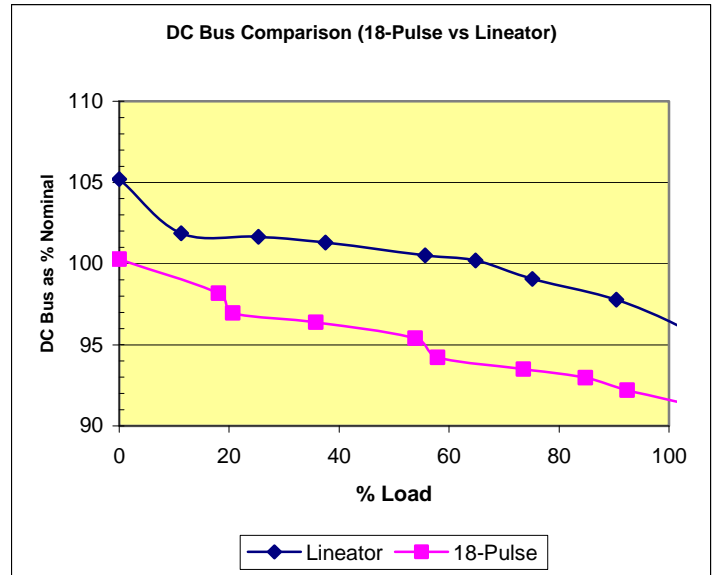

Figure 12-3: DC Bus Voltage comparison – 18-Pulse vs

13. Is the LINEATOR™ compatible with all VFD's?

The standard LINEATOR™ AUHF Type D is designed to reduce the harmonic currents generated by an AC PWM Variable Frequency Drive equipped with a 6-pulse diode bridge rectifier. This includes a VFD that uses an SCR bridge for pre-charge purposes. It is compatible with all PWM AC Drive configurations.

For thyristor bridge (or SCR) applications, such as DC Drives and industrial rectifiers, a Type T LINEATOR should be selected. The Type T unit is designed to accept the phase back angle introduced by the thyristor operation. Reduction of current distortion will be slightly less than that achieved with a Type D unit operating on a diode bridge but still will achieve < 8% ITHD at full load operation.

[<Back to Questions>](#)

14. Is the LINEATOR suitable for generator applications?

In general, generators are reasonably well equipped to handle resistive or inductive loads but do not perform well under highly capacitive loading. This is primarily due to the inability of the generator's excitation controls to adjust to the voltage boost that the capacitors will introduce.

Figure 14-1 shows a typical Reactive Capability Curve for a generator. Reactive power in kVAR as a % of the generator's rated kVA is shown on the X-axis with lagging or inductive loads on the left side and leading or capacitive loads on the right side. Generator loading in KW as a % of rated kVA is shown on the Y-axis. The generator will operate properly with any loading that falls inside the outer curves.

As can be seen, the generator handles well any heavy inductive loads over its entire load range, accepting up to 85% inductive reactance at no load and 60% at full load. It performs less well however, when the loading is capacitive. At no load, capacitive reactive must be less than 20%.

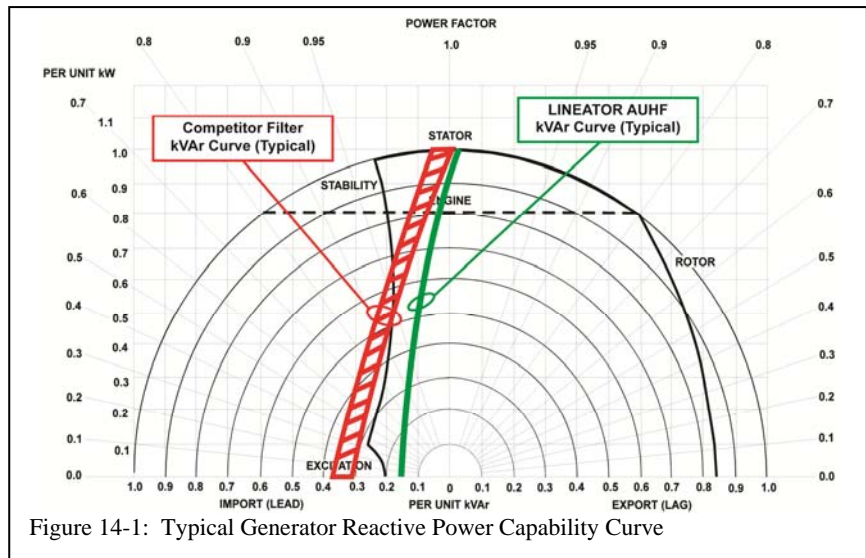

Figure 14-1: Typical Generator Reactive Power Capability Curve

Most competitive passive filters require large capacitor banks in order to achieve the harmonic reduction performance of the LINEATOR AUHF. As a result, they are very rarely suitable for generator applications. The unique configuration of the LINEATOR reactor, on the other hand, allows for a much smaller capacitor bank which ensures that it is compatible with the generator. The green trace in Figure 14-1 shows the maximum capacitive reactance of the LINEATOR AUHF. Even at no load, it is very comfortably lower than the maximum allowed (<15%). The red trace shows the typical capacitive reactance values of competitive filters which falls outside the acceptable limits. As a result, the LINEATOR can be guaranteed to operate without problems on any generator application whereas competitive filters cannot.

15. What if my VFD is equipped with a by-pass?

On Variable Frequency Drive (VFD) installations designed or specified with a bypass circuit, it is recommended that the LINEATOR™ AUHF be installed within the bypass circuit as shown in Figure 15-1.

When the LINEATOR™ is left in the circuit with the VFD bypassed, its through impedance will cause a voltage drop at the motor. This typically will not be enough to under excite or completely ‘starve the motor of voltage’ but will cause the motor to draw more current to compensate for the lower voltage. This could lead to slightly higher slip, heavier losses, lower torque and the potential for overheating. If it is determined that the motor can accept the voltage drop, then the LINEATOR can be left in the circuit when the VFD is being by-passed.

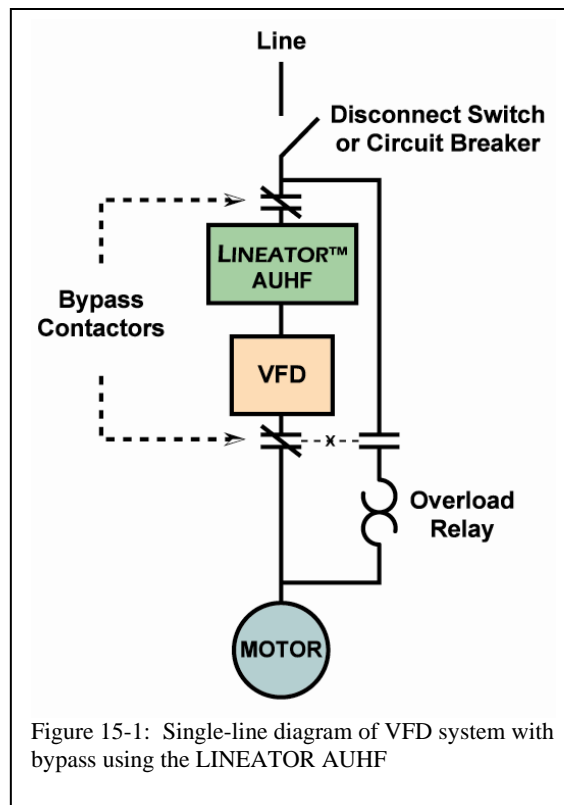

16. Can I use a single LINEATOR to supply multiple VFD's?

A single LINEATOR™ can be used to supply multiple VFD's but in such an application all downstream loads must be VFD's. The trapezoidal output voltage of the LINEATOR™, although ideal for a VFD application, is not suitable for fixed speed motors or other linear loads.

[<Back to Questions>](#)

17. Can I get a computer simulation to demonstrate compliance with IEEE Std 519 or simply to show the LINEATOR™'s effectiveness in a specific application?

In many applications, it is desirable to perform computer simulations prior to the VFD installation in order to ensure that the design will meet harmonic limits as defined in IEEE Std 519 or some other harmonic standard. In order to provide this service to our customers, Mirus has developed a custom computer simulation program, known as 'SOLV', which has been field proven to provide an accurate prediction of performance provided proper system information is applied. If a computer simulation is required, simply contact Mirus technical support.

[<Back to Questions>](#)

18. What kind of performance guarantee does the LINEATOR™ have?

Mirus has the best performance guarantee in the industry because, unlike most competitive filters, it is not conditional upon pre-existing voltage distortion or system impedance levels. The standard LINEATOR guarantee is as follows:

MIRUS guarantees that the LINEATOR™ AUHF will perform as advertised to reduce harmonic distortion caused by AC Variable Speed Drives and other non-linear loads equipped with 3-phase, 6-pulse, diode bridge rectifiers. A properly selected and installed LINEATOR™ will:

1. Reduce Current Total Harmonic Distortion (ITHD), as measured at the LINEATOR™ input terminals, to < 8% at full load operation.
2. Reduce Current Total Demand Distortion (ITDD), as measured at the LINEATOR™ input terminals, to < 8% over the entire operating range.
3. Minimize the contribution to Voltage Harmonic Distortion of all VSD's equipped with the LINEATOR™ to < 5% total and < 3% for individual harmonics, as defined by IEEE Std 519-1992.
4. NOT become overloaded by other upstream harmonic sources.
5. NOT resonate with other power system components.
6. NOT have compatibility problems with engine generator sets properly sized for the load.

MIRUS' entire liability and Purchaser's exclusive remedy, at MIRUS' sole discretion, shall be the repair, replacement or full refund of purchase price of the product that does not meet MIRUS' Performance Guarantee and which is returned to MIRUS with a written authorization and a copy of the paid invoice. This guarantee is void if failure of the product has resulted from accident, abuse or misapplication.

In no event shall MIRUS be liable for loss, damage, or expense directly or indirectly arising from the use of the product, or from any other cause, except as expressly stated in this guarantee. MIRUS makes no warranties, expressed or implied, including any warranty as to the merchantability or fitness for a particular purpose or use other than as stated herein. MIRUS is not liable for any consequential or special damages arising out of any breach of warranty, and for any operation or maintenance of the product.

19. What information is required to properly apply the LINEATOR™ AUHF?

Review of the following questions prior to the use of a LINEATOR AUHF on a VFD application will assist in ensuring a trouble-free installation.

1. What is the system voltage and frequency?

The LINEATOR™ is available in both 50Hz and 60Hz and all nominal voltages up to 690V.

2. What is the HP rating of the VFD and motor?

For ease of application, VFD's are typically rated to motor shaft HP. To match this convention, the LINEATOR™ has also been rated to motor shaft HP. Therefore, a 100 HP application would normally call for a 100 HP VFD and a matching 100 HP LINEATOR™. The VFD is designed to handle motor losses as well as motor shaft power while the LINEATOR™ is designed for both motor losses and VFD losses in addition to motor shaft HP. LINEATOR™ performance is guaranteed to be <8% ITHD at full load and <8% ITDD over the full operating range of the VFD. Occasionally, an application will call for a VFD that has been oversized relative to the motor shaft HP (ie. motor is expected to be replaced with a larger one at a later date). The LINEATOR™ should be sized to match this higher rated VFD but there will be a slight compromise in performance since the full load rating of the LINEATOR™ will not be reached when the motor is undersized.

3. What type of load is the motor driving, i.e. fan, pump etc.?

The LINEATOR AUHF is designed to handle any motor load, be it variable or constant torque. Some VFD's are dual rated so care should be taken to match the appropriate VFD rating for the load.

4. Is the rectifier a simple diode bridge (as in standard PWM AC Drives) or a thyristor bridge (as in DC Drives or industrial rectifiers)?

The LINEATOR AUHF is available in two model types – Type D and Type T. Type D is used on standard diode bridge rectifiers and Type T is used on thyristor bridge rectifiers (or SCR). Typically Type T units will be one size larger than their Type D equivalent.

5. What is the VFD model number and manufacturers name?

Basic information on the type of VFD will help ensure that the appropriate LINEATOR™ model is chosen.

6. What is the KVA rating and %Z of the transformer or generator feeding the VFD?

If we can collect this type of information along with a single line diagram we can use MIRUS' SOLV computer simulation software to predict the level of harmonics with and without the LINEATOR™ installed to demonstrate its ability to meet IEEE Std 519 limits.

7. Does the VFD have a bypass circuit arrangement?

If the VFD has a bypass circuit, it is recommended that the LINEATOR™ be connected to the VFD such that it can be bypassed along with the VFD. However, if it is determined that the motor can withstand the voltage drop introduced by the LINEATOR™, it may be left in the circuit during VFD by-pass.

8. Will the LINEATOR™ be used on multiple VFD's or have loads connected downstream that are not VFD's?

A single LINEATOR™ can be used to supply multiple VFD's but in such an application all downstream loads must be VFD's. The trapezoidal output voltage of the LINEATOR™, although ideal for a VFD application, is not suitable for fixed speed motors or other linear loads.