



Figure 1. 40 Series Brake

Standard Housing		Wt. Lbs.		Inertia Rotating Parts
Model	Torque Lb. Ft.	Net	Pkg'd	WK ² in Lb. Ft. ²
2-42001-012	3/4 or 3/8	1 1/2	2 1/2	.001

Table 1. List of Models

WARNING

Brake performance and features must be carefully matched to the requirements of the application. Consideration must be given to torque requirements, especially where an overhauling condition exists, as well as thermal capacity, ambient temperature, atmospheric explosion hazards, type of enclosure and any other unusual conditions. Improper selection and installation of a brake and/or lack of maintenance may cause brake failure which could result in damage to property and/or injury to personnel. If injury to personnel could be caused by brake failure, additional means must be provided to insure safety of personnel. Do not operate manual release or energize brake coil before installation, in order to preserve prealignment of rotating discs for ease of installation.

IMPORTANT
Read this bulletin carefully before installing or operating this brake. Failure to comply with these instructions cancels all warranties.

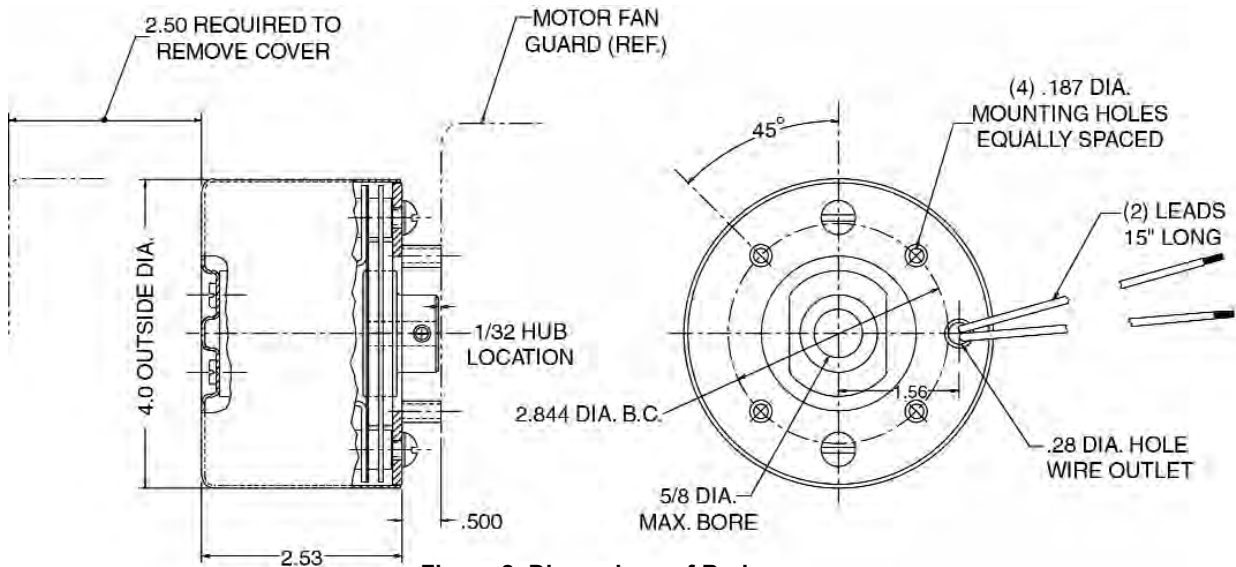

Figure 2. Dimensions of Brake

G040099-001

DESCRIPTION

This brake is spring set, electromagnetically released. It uses rotating and stationary disc contact to supply positive braking action. When energized, the release mechanism compresses a spring removing force on a pressure plate, and permits free rotation of a motor shaft.

Simplicity of design has reduced maintenance to an absolute minimum. As with any electromechanical equipment, however, periodic inspection and adjustment will assure optimum performance. As the friction disc wears, the magnet gap will increase. The magnet gap should be checked periodically and adjusted when necessary. NOTE: This brake is not intended for accurate positioning applications. It is designed for applications that require rapid stopping and holding power such as conveyors, door openers, etc.

INSTALLATION (See Figures 2, 3, 4 & 5)

Before installing, refer to section on Torque Selection.

1. Position hub (8) on motor shaft 1/32" from mounting surface of motor fan guard and securely tighten both set screws. Bore in hub (See Figure 2) is designed to give minimum clearance between hub and motor shaft. If hub is tight on shaft, use emery cloth on motor shaft, so that hub slides on freely. Loctite or similar adhesive may be used on motor shaft extension.
2. Remove cover screws (17), lockwashers (18) and cover (16).
3. Place brake on motor, guiding rotating discs (9) on hub. Mount brake so that grommet (7) is on the wire connection box side of motor. Depress operator assembly lever (19) and align discs if needed. Attach brake securely to motor mounting surface using machine screws (5), lock washer (4) and spacers (2). Use of needlenose pliers to guide and hold spacer may be helpful. Brake bracket (3) is to be concentric with motor shaft within .010 T.I.R. and square within .010.
4. Brake is connected in parallel with motor line leads, therefore brake is energized when power is applied to motor (115V, 60Hz).
5. Energize brake and motor briefly to insure proper action.
6. Bring solenoid lead wires thru grommet (7) to make the electrical connection. Replace cover and cover screws.

TORQUE SELECTION

The brake is designed so that the torque can be changed from 3/4 lb. ft. to 3/8 lb. ft.

The brake as furnished has two rotating discs (9), and will have a nominal static torque rating of 3/4 lb. ft. To reduce torque to 3/8 lb. ft. a rotating disc must be removed and the solenoid air gap has to be readjusted. Proceed as follows:

Depress solenoid plunger and remove the rotating disc (9) which is closest to the solenoid. Release plunger. Set air gap "A" at 3/8 inches by turning set screw (23) clockwise. Depress solenoid plunger several times and recheck air gap "A".

MAINTENANCE AND SERVICE

FRICITION DISC REPLACEMENT (See Figures 3 & 5)

CAUTION: High start-stop rates may damage motor and/or brake. Consult motor manufacturer whenever high cycling rates are involved.

When total wear on rotating discs (9) reaches .04", replace discs as follows:

1. Disconnect solenoid (25) from circuit and remove cover (16).
2. Remove locknuts (15), washers (14), operator assembly (13), pressure plate (12), stationary disc (11), friction disc (9), stationary disc (10), and friction disc (9).
3. Replace worn discs and assemble in reverse order. Discs must slide freely on hub (8).

NOTE: Stationary disc (10) is .060 in. thick, and must be in the location shown in Fig. 5. Stationary disc (11) is .030 in. thick, and must be located as shown.

4. Before installing operator assembly (13) turn adjusting screw (23) counterclockwise 4 or 5 turns to allow operator to be bolted down without interference.
5. Readjust air gap "A" (See Wear Adjustment).

SOLENOID REPLACEMENT (See Figure 3)

CAUTION: Load to be removed or blocked. Brake will be inoperative during this procedure.

1. Disconnect solenoid (25) from circuit, and remove cover (16).
2. Remove solenoid assembly (25) and torque spring (21) by removing fillister head screws (28) and split lock washers (27).
3. Insert new solenoid assembly by sliding plunger (20) into slot of operator assembly lever (19), keeping torque spring around plunger.
4. Fasten solenoid assembly to mounting bracket (26) with fillister head screws (28) and split lock washers (27).
5. Adjust air gap "A" (See Wear Adjustment).

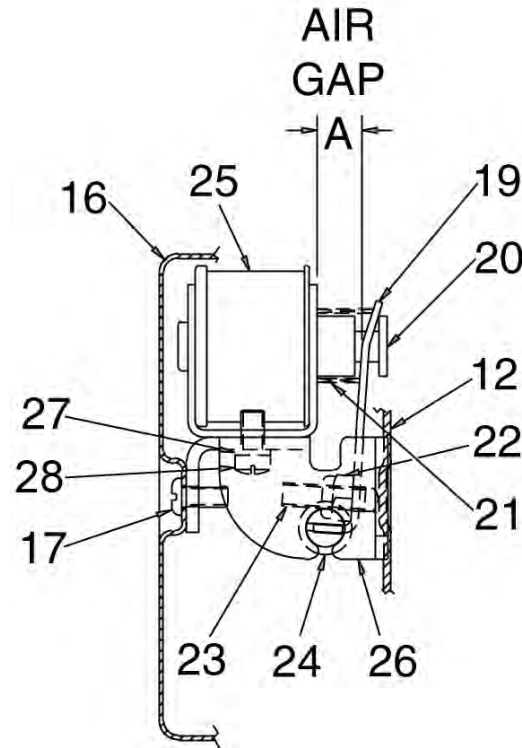

Figure 3. Brake Gap Adjustment

WEAR ADJUSTMENT (See Figure 3).

As friction discs wear, magnet air gap "A" increases, thereby increasing stopping time of brake. Before air gap "A" reaches 7/16" maximum (measured on center line of plunger) adjustment for wear is required. Any delay in adjusting air gap will result in a loss of torque and/or coil burn out.

To adjust brake, proceed as follows:

1. Remove cover (16).
2. Insert allen wrench into adjusting screw (23) and turn clockwise until solenoid air gap is approximately 3/8". Gap is measured between operator assembly lever (19) and solenoid (25) "C" frame, at center line of plunger (20).

NOTE: The 3/8" dimension for the air gap is a nominal position. On low horsepower units, the gap may have to be slightly larger.

Observe motor starting characteristics after adjusting gap. Motor should start quickly. If not, increase air gap by turning adjusting set screw (23) 1/8 turn counterclockwise.

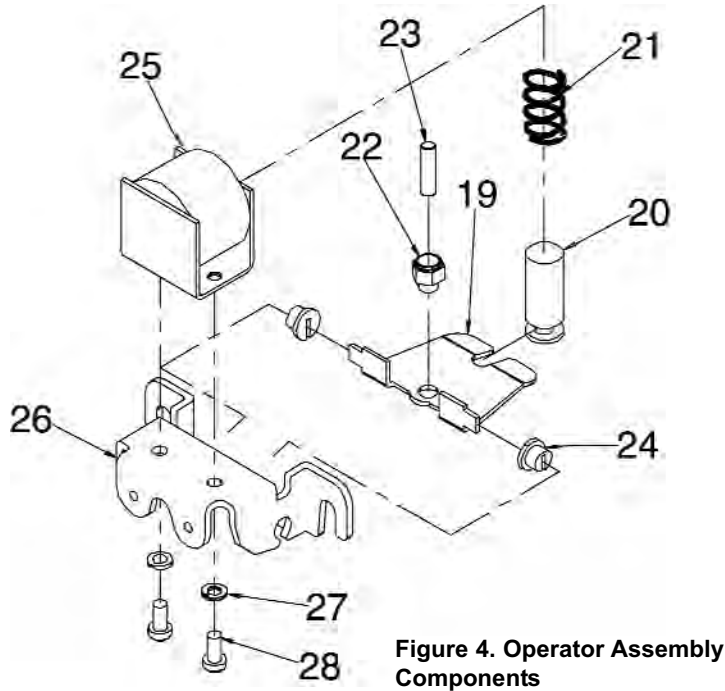

Figure 4. Operator Assembly Components

Table 2. Parts for Operator Assembly*

ITEM NO.	DESCRIPTION
19	Lever Assembly includes Clinch Nut (22)
20	Solenoid Plunger
21	Torque Spring
22	Clinch Nut #10-32
23	Set Screw #10-32x3/4
24	Nylon Bushing
25	Solenoid includes Plunger (20) (115V 60Hz)
26	Mounting Bracket
27	Lock Washer #10
28	Screw Fillister HD #10-32 x .375

*Operator Assembly sold as complete unit only. See Table 3, Item 13.

Table 3. Replacement Parts for Brake Assembly

ITEM NO.	PIECES REQ'D	DESCRIPTION	PART NO.
1	2	Round head screw	W001002-105
2	4	Spacer	G040032-001
3	1	Bracket	G040029-001
4	4	Lockwasher	W004006-003
5	4	Fillister hd screw	W001009-026
6	2	Spacer	G040040-001
7	1	Grommet	W027001-002
8	1	Hub w/ set screws	*
9	2	Rotating disc	G040041-001
10	1	Stationary disc-inner	G040044-001
11	1	Stationary disc-outer	G040042-001
12	1	Pressure plate	H040024-001
13	1	Operator assembly	**
14	2	Washer	W004003-002
15	2	Locknut	W003001-013
16	1	Cover	H040025-001
17	2	Screw, slotted hex washer head	W001046-042
18	2	Lockwasher	W004006-003

*Specify model number and bore size.

**Specify model number, voltage and hertz.

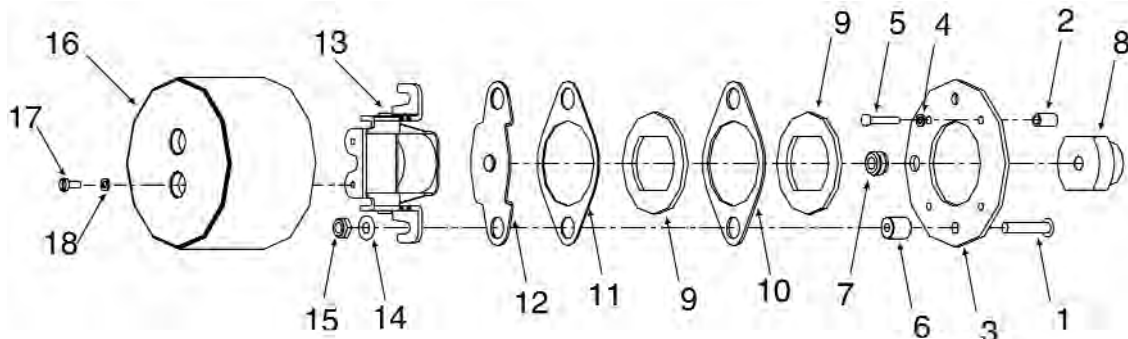

Figure 5. Brake Assembly Components

SYMPTOM	POSSIBLE CAUSE(S)	CORRECTIVE ACTION
Brake does not release.	<ol style="list-style-type: none"> 1. Broken or damaged parts. 2. Wrong voltage. 3. Burned out coil. 4. Incorrect wiring connections or broken wires. 5. Plunger binding due to worn parts. 	<ol style="list-style-type: none"> 1. Replace. 2. Check voltage. Voltage must not vary more than + 10% rated voltage. 3. Replace solenoid assembly (Item No. 25). 4. Check for bad electrical or incorrect connections or broken wires. 5. De-butt plunger (Item No. 20) or replace solenoid (Item No. 25).
Brake does not stop properly.	<ol style="list-style-type: none"> 1. Broken or damaged parts. 2. Worn friction discs. 3. Hub positioned incorrectly. 4. Incorrect alignment between brake and motor shaft. 5. Excessive air gap. 	<ol style="list-style-type: none"> 1. Replace. 2. Replace if worn. Refer to section on Friction Disc Replacement. 3. Refer to section on Installation. Reposition if required. 4. Correct alignment. Refer to section on Installation. 5. Refer to section on Wear Adjustment.
Brake chatters or hums.	<ol style="list-style-type: none"> 1. Wrong voltage supply for coil. 2. Excessive air gap. 3. Loose or broken shading pole, part of solenoid assembly. 4. Wrong size lead wires. 	<ol style="list-style-type: none"> 1. Replace coil with correct voltage rating. 2. Adjust air gap. Refer to section on Wear Adjustment. 3. Clean or replace solenoid assembly (Item No. 25). 4. Disconnect or rewire source voltage to brake.

SPECIFICATIONS

Nominal Static Torque3/4 LB. Ft. (2 rotating discs)
Rating3/8 Lb. Ft. (1 rotating disc)
Inertia of Brake Rotating Parts (WK ²)001 Lb. Ft.
Enclosure	Standard Drip-proof
Input Speed	3600 RPM (max)
Duty Cycle	Continuous
Service Factor	1.0
Maximum Ambient	40°C
*Electrical	{ Voltage Hertz Holding Amps Inrush Amps	115V
		.60
		.016
		.036

*Contact factory for other voltage and frequency.

ORDERING INFORMATION

The following data should be furnished with your order for:

REPLACEMENT PARTS

- Brake Model Number
- Part Number from Table 2 or Table 3
- Part Description from Table 2 or Table 3
(On hub order furnish bore dia. & keyway dimensions)
(On electrical parts specify voltage, phase & frequency)

REPLACEMENT BRAKE

- Model Number
- Voltage, Phase & Frequency
- Hub Bore & Keyway Dimensions

WARRANTY

Seller warrants products manufactured by it and supplied hereunder to be free from defects in materials and workmanship under normal use and proper maintenance for a period of twelve months from date of shipment. If within such period any such products shall be proved to Seller's reasonable satisfaction to be defective, such products shall be repaired or replaced at Seller's option Seller's obligation and Buyer's exclusive remedy hereunder shall be limited to such repair and replacement and shall be conditioned upon Seller's receiving written notice of any alleged defect no later than 10 days after its discovery within the warranty period and, at Seller's option, the return of such products to Seller, f.o.b. its factory, when such return is feasible. Seller reserves the right to satisfy its warranty obligation in full by reimbursing Buyer for all payments it makes hereunder, and Buyer shall thereupon return the products to Seller. Seller shall have the right to remedy such defects. Seller makes no warranty with respect to wear or use items, such as belts, chains, sprockets, discs and coils, all which are sold strictly AS IS.

The foregoing warranties are exclusive and in lieu of all other express and implied warranties (except of title) including but not limited to implied warranties of merchantability, fitness for a particular purpose, performance, or otherwise, and in no event shall the Seller be liable for claims (based upon breach of express or implied warranty, negligence, product liability, or otherwise) for any other damages, whether direct, immediate, incidental, foreseeable, consequential, or special.

