

Baldor SmartMotor™

Installation & Operating Manual



9/02

MN750

57 Galaxy Blvd., Units 1 & 2, Toronto, ON M9W 5P1
TEL: (416) 231-6767
www.drivecentre.ca

Table of Contents

Section 1	
Quick Start Guide	1-1
Section 2	
General Information	2-1
Overview	2-1
Safety Notice:	2-3
Section 3	
Receiving & Installation	3-1
Receiving & Inspection	3-1
Location and Mounting	3-1
Cover Removal	3-1
AC Power Considerations	3-2
AC Line Impedance	3-2
Protective Devices	3-2
Power Disconnect	3-2
AC Power Connections	3-3
DC Power Connections	3-4
Installing Optional Items	3-4
Dynamic Braking (DB) Hardware	3-4
Optional Remote Keypad Mounting	3-4
Analog Input and Output	3-6
Analog Input	3-6
Analog Output	3-6
External Trip Input	3-7
Opto Isolated Inputs and Output	3-7
Opto-isolated Inputs	3-7
Opto-Isolated Output	3-7
Operating Mode & Connection Diagram Examples	3-8
Keypad Operating Mode	3-8
#1, 2 Wire 7 Speed Operating Mode	3-9
#2, 2 Wire External Trip Operating Mode	3-10
#3, 2 Wire 3 Speed Operating Mode	3-11
#4, 3 Wire 3 Speed Operating Mode	3-12
#5, 3 Wire External Trip Operating Mode	3-13
#6, 2 Wire Electronic Pot Operating Mode	3-14
#7, 3 Wire, Electronic Pot Operating Mode	3-15
Profile Run Remote Operating Mode	3-15
Profile Run Local Operating Mode	3-16
PID Operating Mode	3-16
PID:Stop-Mode	3-17
Pre-Operation Checklist	3-17

Section 4	
Programming & Operation	4-1
Overview	4-1
Display Mode	4-2
Adjusting Display Contrast	4-2
Display Screens	4-3
Diagnostic Screens	4-4
Fault Log Access	4-5
Program Mode	4-5
Parameter Blocks Access for Programming	4-6
Changing Parameter Values when Security Code Not Used	4-7
Reset Parameters to Factory Settings	4-8
Operating the SmartMotor from the Keypad	4-9
Using the Keypad JOG Command	4-9
Speed Adjustment from the Keypad	4-10
Speed Adjustment Using Arrow Keys	4-10
Profile Run Changes	4-11
Security System Changes	4-12
Changing Parameter Values with a Security Code in Use	4-13
Security System Access Timeout Parameter Change	4-14
SmartMotor Parameters	4-15
Parameter Description	4-16
Section 5	
Troubleshooting	5-1
Overview	5-1
Troubleshooting	5-1
No Keypad Display	5-1
How to Access Display Screens	5-2
Diagnostic Information Screens	5-3
How to Set Date and Time	5-4
How to Access the Fault Log	5-5
How to Clear the Fault Log	5-5
Restore Factory Parameter Values	5-6
Section 6	
Specifications & Product Data	6-1
Specifications:	6-1
Ratings	6-5
Ratings	6-5
Terminal Tightening Torque Specifications	6-6
Terminal Tightening Torque Specifications	6-6
SmartMotor Dimensions	6-7
Appendix A	A-1
Dynamic Braking (DB) Hardware	A-1
Appendix B	B-1
Parameter Values	B-1
Appendix C	C-1
Remote Keypad Mounting Template	C-2

Section 1

Quick Start Guide

Overview

If you are an experienced user of Baldor controls, you are probably already familiar with the keypad programming and keypad operation methods. If so, this quick start guide has been prepared for you. This procedure will help get your system up and running in the keypad mode quickly and will allow motor and control operation to be verified. This procedure assumes that the Control, Motor and Dynamic Brake hardware are correctly installed (see Section 3 for procedures) and that you have an understanding of the keypad programming & operation procedures. It is not necessary to wire the terminal strip to operate in the Keypad mode (Section 3 describes terminal strip wiring procedures). The quick start procedure is as follows:

1. Read the Safety Notice and Precautions in section 2 of this manual.
2. Mount the drive.
3. Connect AC power. Refer to Section 3 “AC Power Connections”.
4. Plug in the keypad. Refer to Section 3, “Optional Remote Keypad Mounting” procedure.

Check of Electrical Items

1. Verify AC line voltage at source matches the SmartMotor rating.
2. Inspect all power connections for accuracy, workmanship, tightness and compliance to codes.
3. Verify SmartMotor is grounded to earth ground.
4. Check all signal wiring for accuracy.
5. Be certain all brake coils, contactors and relay coils have noise suppression. This should be an R-C filter for AC coils and reverse polarity diodes for DC coils. MOV type transient suppression is not adequate.

Check of Motor and Coupling

1. Verify freedom of motion of the motor shaft.
2. Verify that motor coupling is tight without backlash.
3. Verify the holding brakes, if any, are properly adjusted to fully release and set to the desired torque value.

Temporary Application of Power

1. Check all electrical and mechanical connections before applying power to the SmartMotor.
2. Verify that control logic inputs at the J1 connector are proper.
3. Temporarily apply power and observe that the bus power indicator is on or that the optional keypad display is on (if Keypad is connected). If this indication does not occur, check all connections and verify input voltage. If fault indication occurs, refer to the troubleshooting section of this manual.
4. Disconnect all power from the SmartMotor.

Minimum Required Parameter Settings and Control Set-up Checklist

If you are familiar with programming Baldor controls continue with the following steps. If not, proceed to the programming section of this manual before applying power to the drive.

Note: This list is the minimum program parameters required for operation of the control for initial start-up.

⚠ WARNING: Make sure that unexpected operation of the motor shaft during start up will not cause injury to personnel or damage to equipment.

1. Be sure drive operation is terminated and secured.
2. Remove all power sources from the motor. Wait at least 5 minutes before proceeding to step 3.
3. Remove cover. Remove the four (4) screws that secure the control cover and remove cover.
4. Connect the optional Keypad to the Keypad Connector (Figure 3-1). Run the keypad wires through the conduit to motor case.
5. Install the control cover. Place the cover on the control and install & tighten the four (4) screws that secure the control cover.
6. Apply power to the SmartMotor.
7. Set the operating mode at the Level 1 Input block Operating Mode parameter.
8. Set the desired minimum output frequency by setting the Min Output Freq parameter in the Level 2 Output Limits block.
9. Set the desired maximum output frequency by setting the Max Output Freq parameter in the Level 2 Output Limits block.
10. If the desired peak current limit is different than presently set the PK Current Limit parameter in the Level 2 Output Limits block.
11. If using an external analog command, check ANA CMD Select parameter to verify the SmartMotor is ready to accept your analog command signal.
12. Set the desired Volts/Hertz ratio by setting the V/HZ Profile Parameter in the Level 2 V/HZ and Boost Block.
13. If the load is a high initial starting torque type, the Torque Boost parameter in the Level 1 V/HZ and Boost Block may need to be increased. Also, the ACCEL TIME #1 parameter in the Level 1 ACCEL/DECEL Rate block may need to be increased.
14. Set the date and time parameter in the Diagnostic Info screens.
15. Select and program additional parameters to suit your application.

Section 2 General Information

Overview

The Baldor SmartMotor™ is an integrated industrial motor and inverter control that is simple and fast to install. Using Baldor SmartMotor™ will give you:

Designed Motor and Control Compatibility - By integrating the control electronics and the motor during the design and manufacturing process, we achieve better performance and compatibility. Just size the drive to the load characteristics. We even make sizing to the load characteristics easy by providing a Matched Performance™ curve.

Fewer Wiring Mistakes - Let Baldor pre-wire the motor to the control and eliminate one major wiring mistake potential. Just connect power and control wiring (if necessary) and you're ready to run. In addition, you save the cost of the wire and conduit between the motor and control. That is just another way Baldor adds value to our products. Baldor saves you money and eliminates expensive errors.

Fewer Programming Errors - How many hours have been spent trying to program the motor control to the motor characteristics? The Baldor SmartMotor™ is a factory assembled motor drive. Baldor pre-programs all the required motor setup adjustments. If you prefer, you can still access all the normal inverter adjustments through the optional keypad or standard RS-485 port to custom tailor your particular application.

Eliminate Reflected Wave Voltage - You may know this phenomenon by other names such as standing wave or voltage ring-up. If the distance between the motor and control is long and the switching frequency is just right, a standing wave can form between the motor and control. These standing waves can increase the voltage at the motor terminals causing the motor to fail prematurely. Locating the control near the motor can keep this problem from occurring. Until now it was not always possible to prevent long motor to control distances. The distance between the Baldor SmartMotor™ control and motor is measured in inches not feet.

Eliminate Panel Space - Trying to retrofit an existing fixed speed application to incorporate variable speed control and don't have the panel space to mount a motor control? Not a problem with the Baldor SmartMotor™. Since the control electronics are integrated into the motor design you only need to supply a power disconnect. In many cases you can probably use the existing wiring and conduit running to the motor location.

Power Module - The Baldor SmartMotor™ uses a definite purpose integrated power module specifically designed for Baldor SmartMotor™ use. Environmental heating is the most damaging element for motor and control design. By using a definite purpose power module Baldor reduces the potential for damaging heat generated from the motor or control. Simply taking a micro inverter and mounting it to a motor will not allow for cost effective integration. Premature failure has not been eliminated because the motor control electronics were not designed for high ambient temperature operations.

Patented TEFC Control Electronics Cooling - By using the motor shaft mounted cooling fan we can offer smaller package sizes and cost effective cooling for the motor and control. This patented design has been refined over several generations of products and the result can be seen on the Baldor SmartMotor™.

High Efficiency Inverter Duty Motor Designs - Building on Baldor's many years of experience in designing and manufacturing inverter duty motors, the Baldor SmartMotor™ incorporates the same design features as offered in our industry standard inverter duty motor product line. Some of the many features include Class H insulation system, 200°C Inverter Spike Resistant (ISR) magnet wire, low loss motor lamination, and precision rotor balance.

DC Bus Powered Logic Supply - The control circuitry is powered from the control's internal DC Bus for greater noise immunity and increased reliability. Additionally the power-loss-ride-through capability is increased when compared to designs using AC powered logic. The Baldor SmartMotor™ can be operated directly from a DC source such as found in automotive air conditioners and other battery powered devices.

Limited Warranty

For a period of two (2) years from the date of original purchase, BALDOR will repair or replace without charge controls which our examination proves to be defective in material or workmanship. This warranty is valid if the unit has not been tampered with by unauthorized persons, misused, abused, or improperly installed and has been used in accordance with the instructions and/or ratings supplied. This warranty is in lieu of any other warranty or guarantee expressed or implied. BALDOR shall not be held responsible for any expense (including installation and removal), inconvenience, or consequential damage, including injury to any person or property caused by items of our manufacture or sale. (Some states do not allow exclusion or limitation of incidental or consequential damages, so the above exclusion may not apply.) In any event, BALDOR's total liability, under all circumstances, shall not exceed the full purchase price of the control. Claims for purchase price refunds, repairs, or replacements must be referred to BALDOR with all pertinent data as to the defect, the date purchased, the task performed by the control, and the problem encountered. No liability is assumed for expendable items such as fuses.

Goods may be returned only with written notification including a BALDOR Return Authorization Number and any return shipments must be prepaid.

Safety Notice:

This equipment contains voltages that may be as great as 1000 volts! Electrical shock can cause serious or fatal injury. Only qualified personnel should attempt the start-up procedure or troubleshoot this equipment.

This equipment may be connected to other machines that have rotating parts or parts that are driven by this equipment. Improper use can cause serious or fatal injury. Only qualified personnel should attempt the start-up procedure or troubleshoot this equipment.

Precautions:

- ⚠ WARNING:** Be sure that you are completely familiar with the safe operation of this equipment. This equipment may be connected to other machines that have rotating parts or parts that are controlled by this equipment. Improper use can cause serious or fatal injury. Only qualified personnel should attempt the start-up procedure or troubleshoot this equipment.
- ⚠ WARNING:** SmartMotor is factory set to Remote operation mode. This means that if enabled (switch settings) the motor will run when power is applied. Be sure it is safe to run motor before power is applied.
- ⚠ WARNING:** Make sure that unexpected operation of the motor shaft during start will not cause injury to personnel or damage to equipment.
- ⚠ WARNING:** Do not attempt to service this equipment while bus voltage is present within the control. Remove input power and wait at least 5 minutes for the residual voltage in the bus capacitors to dissipate.
- ⚠ WARNING:** This unit has an automatic restart feature that will start the motor whenever input power is applied and a RUN (FWD or REV) command is issued and maintained. If an automatic restart of the motor could cause injury to personnel, the automatic restart feature should be disabled. Disable by changing the “Restart Auto/Man” parameter to MANUAL.
- ⚠ WARNING:** Be sure the system is properly grounded before applying power. Do not apply AC power before you ensure that all grounding instructions have been followed. Electrical shock can cause serious or fatal injury.
- ⚠ WARNING:** Do not remove cover for at least five (5) minutes after AC power is disconnected to allow capacitors to discharge. Dangerous voltages are present inside the equipment. Electrical shock can cause serious or fatal injury.
- ⚠ WARNING:** Improper operation of control may cause violent motion of the motor shaft and driven equipment. Be certain that unexpected motor shaft movement will not cause injury to personnel or damage to equipment. Peak torque of several times the rated motor torque can occur during control failure.
- ⚠ WARNING:** Motor circuit may have high voltage present whenever AC power is applied, even when motor is not rotating. Electrical shock can cause serious or fatal injury.

Continued on Next Page.

-
- ⚠ Caution:** Suitable for use on a circuit capable of delivering not more than 5000 RMS symmetrical short circuit amperes at rated voltage.
 - ⚠ Caution:** Do not mount the SmartMotor with the control cover in the down position. The cover must face up or to one side to keep liquids and contaminants away from the heatsink.
 - ⚠ Caution:** Avoid locating the SmartMotor immediately above or beside heat generating equipment, or directly below water or steam pipes.
 - ⚠ Caution:** Do not use power factor correction capacitors on the input power lines to the SmartMotor. Damage to the control may result if they are used.
 - ⚠ Caution:** Increasing the Torque Boost value may cause the motor to overheat at low speed.

Section 3

Receiving & Installation

Receiving & Inspection

The SmartMotor™ is thoroughly tested at the factory and carefully packaged for shipment. When you receive your drive, there are several things you should do immediately.

1. Observe the condition of the shipping container and report any damage immediately to the commercial carrier that delivered your control.
2. Verify that the part number of the control you received is the same as the part number listed on your purchase order.
3. If the control is to be stored for several weeks before use, be sure that it is stored in a location that conforms to published storage specifications. (Refer to Section 6 of this manual).

Location and Mounting

This section describes the proper mounting and wiring procedure of the Baldor SmartMotor™. If problems arise after installation, please refer to the Diagnostics and Troubleshooting section of this manual.

Select a mounting surface for the SmartMotor that allows installation using the mounting holes provided. The area selected should allow for free air circulation around the control. Provide at least two inches of clearance on all sides for maximum cooling efficiency.

Vibration Considerations

Excessive vibration can cause failure of the control. If control is subjected to vibration levels greater than 1G at 10 to 60 Hz, the control must be shock mounted.

Altitude Derating

Ratings apply to 3300 feet (1000 meters) altitude with no derating required. For installations at higher altitudes derate the continuous and peak output currents of the control by 2% for each 1000 feet above 3300 feet.

Temperature Derating

Control ratings apply to 40°C. Derate output by 2% per °C above 40°C. Maximum ambient is 55°C.

Wiring Consideration

All connections are at the connectors shown in Figures 3-2 and 3-3. All external wires for the SmartMotor should be run in a conduit that is separate from all other wiring. Be sure to use Class 1 wiring. The use of shielded wire is recommended for all control wiring.

Cover Removal

1. Be sure drive operation is terminated and secured.
2. Remove all power sources from the motor.
3. Remove cover. Remove the four (4) screws that secure the control cover and remove cover.
4. When wiring procedures etc. are complete, install the control cover. Place the cover on the control and install & tighten the four (4) screws that secure the control cover.

AC Power Considerations

Interconnection wiring is required between components such as the AC power source, SmartMotor, optional operator control stations, etc. Wire connectors that are used must be the correct size and installed using the crimp tool specified by the connector manufacturer.

System Grounding

Baldor Controls are designed to be powered from standard three phase lines that are electrically symmetrical with respect to ground. System grounding is an important step in the overall installation to prevent problems. The recommended grounding method is shown in Figure 3-1.

Figure 3-1 Recommended System Grounding

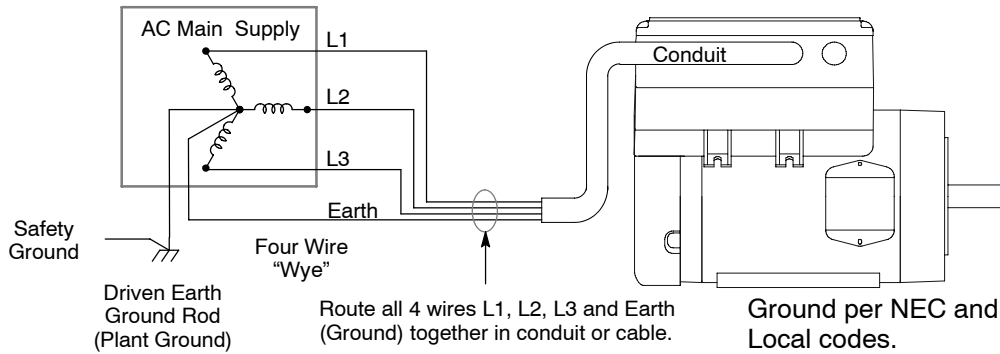

Ungrounded Distribution System

With an ungrounded power distribution system it is possible to have a continuous current path to ground through the MOV devices. To avoid equipment damage, an isolation transformer with a grounded secondary is recommended. This provides three phase AC power that is symmetrical with respect to ground.

AC Line Impedance

The Baldor control requires a minimum line impedance of 1% (voltage drop at the input is 1% minimum at rated input current). If the incoming power line does not have a minimum of 1% impedance, a 3 phase line reactor can be used to provide the needed impedance in most cases. Line reactors are optional and are available from Baldor.

The input impedance of the power lines can be determined as follows:

Measure the line to line voltage at no load and at full rated load.
Use these measured values to calculate impedance as follows:

$$\% \text{Impedance} = \frac{(\text{Volts}_{\text{No Load Speed}} - \text{Volts}_{\text{Full Load Speed}})}{(\text{Volts}_{\text{No Load Speed}})} \times 100$$

Note: Continuous input current requirement is provided in Table 3-1.

$$L = \frac{(V_{L-L} \times 0.01)}{(I \times 1.732 \times 377)}$$

- Where:
- L = minimum line inductance in Henries
 - V_{L-L} = input voltage measured from line to line
 - 0.01 = desired percentage of impedance
 - I = the continuous input current rating of the control
 - 1.732 = square root of three
 - 377 = constant used if the input frequency is 60 Hz.
Use 314 if the Input frequency is 50 Hz.

Line reactors serve several purposes which include:

1. Minimize voltage spikes from the power line that may otherwise cause the control to trip on over voltage spikes.
2. Minimize voltage harmonics from the control to the power line.
3. Provide additional short circuit capability at the control.

Protective Devices

Be sure a suitable input power protection device is installed. Use the recommended circuit breaker or fuses listed in Table 3-1. Input and output wire size is based on the use of copper conductor wire rated at 75 °C. The table is specified for SmartMotors that use a NEMA B motor design.

- Circuit Breaker: 3 phase, thermal magnetic.
Equal to GE type THQ or
TEB for 230 VAC or
GE type TED for 460 VAC.
- Fast Action Fuses: Buss KTN on 230 VAC or
Buss KTS on 460 VAC.
- Very Fast Action: Buss JJN on 230 VAC, or
Buss JJS on 460 VAC.
- Time Delay Fuses: Buss FRN on 230 VAC or
Buss FRS on 460 VAC.

Power Disconnect

A power disconnect should be installed between the input power service and the SmartMotor for a fail safe method to disconnect power. The SmartMotor will remain in a powered-up condition until all input power is removed from the control and the internal bus voltage is depleted.

Table 3-1 - SmartMotor Wire Size and Protection Devices

Catalog Number	Max Constant Torque HP	Input Wire		Input Breaker (240V=TEB, 460V=TED) Amps	Input Fuses Fast Acting (230V=KTN, 460V=KTS) Amps	Input Fuses Time Delay (230V=FRN, 460V=FRS) Amps
		AWG	mm ²			
NEMA 1 - 230 Volt Input						
CSM3546T - 2	1	14	2.08	7	6	5
CSM3558T - 2	2	14	2.08	15	12	9
CSM3611T - 2	3	14	2.08	15	15	12
CSM3615T - 2	5	12	3.31	20	25	20
CSM3710T - 2	7.5	10	5.26	30	35	30
CSM3714T - 2	10	10	5.26	40	45	35
NEMA 1 - 460 Volt Input						
CSM3546T - 4	1	14	2.08	3	3	2.5
CSM3558T - 4	2	14	2.08	7	5	4.5
CSM3611T - 4	3	14	2.08	7	8	6.3
CSM3615T - 4	5	14	2.08	15	12	10
CSM3710T - 4	7.5	14	2.08	15	17.5	15
CSM3714T - 4	10	14	2.08	20	20	17.5
NEMA 4 - 230 Volt Input						
CWDSM3546T - 2	1	14	2.08	7	6	5
CWDSM3558T - 2	2	14	2.08	15	12	9
CWDSM3611T - 2	3	14	2.08	15	15	12
CWDSM3615T - 2	5	12	3.31	20	25	20
CWDSM3710T - 2	7.5	10	5.26	30	35	30
CWDSM3714T - 2	10	10	5.26	40	45	35
NEMA 4 - 460 Volt Input						
CWDSM3546T - 4	1	14	2.08	3	3	2.5
CWDSM3558T - 4	2	14	2.08	7	5	4.5
CWDSM3611T - 4	3	14	2.08	7	8	6.3
CWDSM3615T - 4	5	14	2.08	15	12	10
CWDSM3710T - 4	7.5	14	2.08	15	17.5	15
CWDSM3714T - 4	10	14	2.08	20	20	17.5

Note: All wire sizes are based on 75° C copper wire. Smaller gauge wire that has a greater temperature rating may be used per NEC and local codes. Recommended breakers/fuses are based on 25° C ambient, MAX continuous output current and no harmonic current.

AC Power Connections Figures 3-2 and 3-3 show the 3 phase power connections. Connect input AC power to L1, L2 and L3. The phase rotation is not important as the control is not phase sensitive.

Single Phase Power Connections (1 & 2 HP versions only do not require derating)

Connect AC L1 to SmartMotor terminal L1.

Connect AC Neutral to SmartMotor terminal L2.

Jumper SmartMotor terminals L2 and L3 together. Use same wire size specified in Table 3-1 for L2/L3 jumper.

Derating:

1 - 2 hp No derating required.

3-10 hp Derate hp by 40% of the nameplate rating.

DC Power Connections Operation of the SmartMotor using a DC power source is possible. The DC power leads should be connected to L1 and L2 using disconnect and protection devices. The DC voltage level must be equivalent to the full wave rectified value of the nominal rated AC input voltage. For example, 280 to 340 VDC (for a 230 VAC rating) and 535 to 680 VDC (for a 460 VAC rating). Protective devices should be sized using the equivalent AC ratings.

Installing Optional Items

Dynamic Braking (DB) Hardware Each SmartMotor is equipped with a factory installed dynamic brake transistor and brake resistor. These can provide 100% braking torque for 6 seconds of a 20% braking duty cycle. If the application requires additional dynamic braking capability, an optional external braking kit may be required. Please contact Baldor for availability and selection of DB hardware. Brake calculation methods are given in Appendix A.

Optional Remote Keypad Mounting The optional keypad may be remotely mounted using the optional Baldor keypad extension cable. The keypad assembly comes complete with the screws and gasket required to mount it to an enclosure. When the keypad is properly mounted to a NEMA Type 4 enclosure, it retains the Type 4 indoor rating.

Tools Required:

- Drill motor, center punch, tap handle, screwdrivers (Phillips and straight) and crescent wrench.
- 8-32 tap and #29 drill bit.
- 1-1/4" standard knockout punch (1-11/16" nominal diameter).
- RTV sealant.
- (4) 8-32 nuts and lock washers.
- Extended 8-32 screws (socket fillister) are required if the mounting surface is thicker than 12 gauge and is not tapped (clearance mounting holes).
- Remote keypad mounting template. (See Appendix B for template. Tear out copy is included at the end of this manual).

Mounting Instructions: (See Appendix B)

For tapped mounting holes

1. Locate a flat mounting surface that is a minimum of 4" wide x 5.5" high. Material should be sufficient thickness (14 gauge minimum).
2. Place the template on the mounting surface or mark the holes as shown on the template.
3. Accurately center punch the 4 mounting holes (marked A) and the large knockout (marked B).
4. Drill four #29 mounting holes (A). Thread each hole using an 8-32 tap.
5. Locate the 1-1/4" knockout center (B) and punch using the manufacturers instructions.
6. Debur knockout and mounting holes making sure the panel stays clean and flat.
7. Apply RTV to the 4 holes marked (A).
8. Assemble the keypad to the panel. Use 8-32 screws, nuts and lock washers.
9. From the inside of the panel, apply RTV over each of the four mounting screws and nuts. Cover a 3/4" area around each screw while making sure to completely encapsulate the nut and washer.

Figure 3-1 Baldor SmartMotor™ 35 Frame Connections

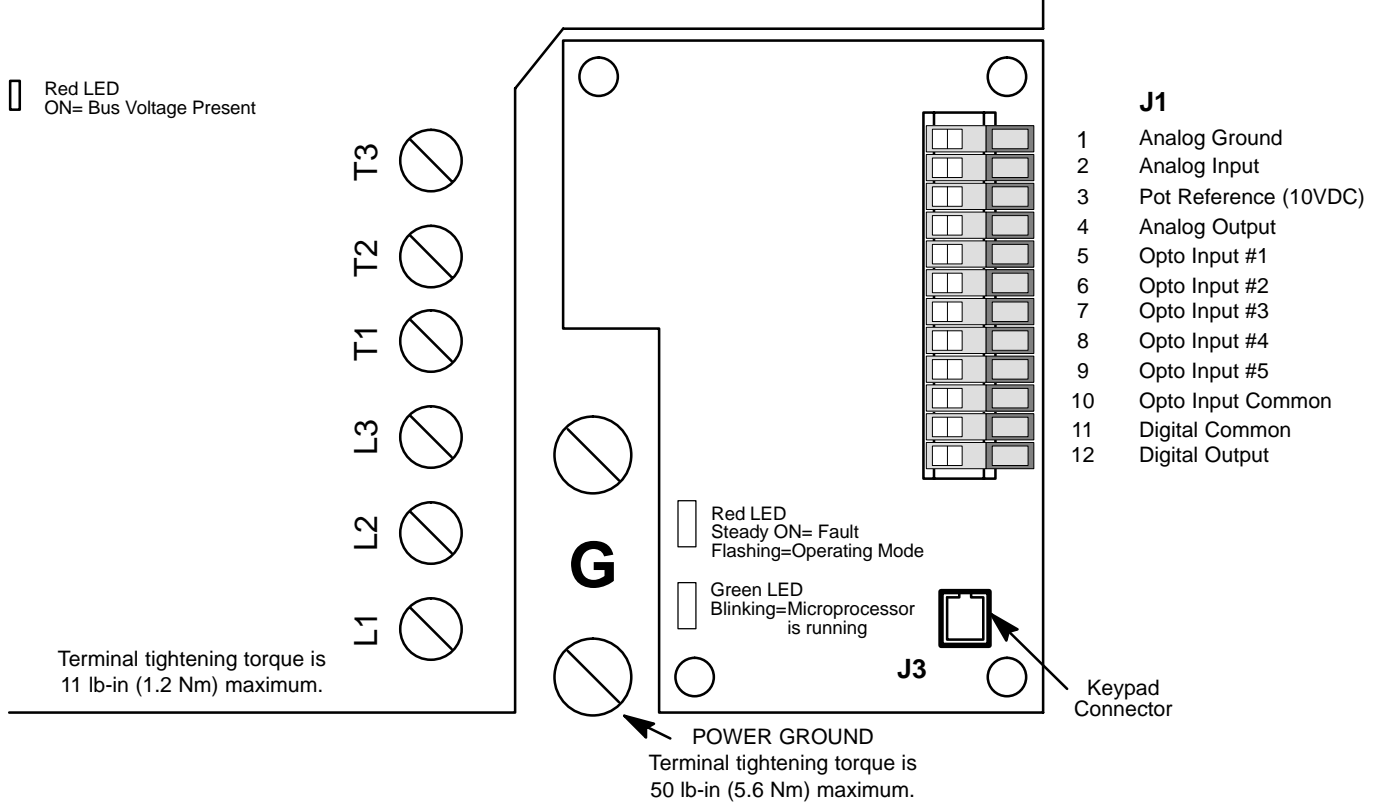
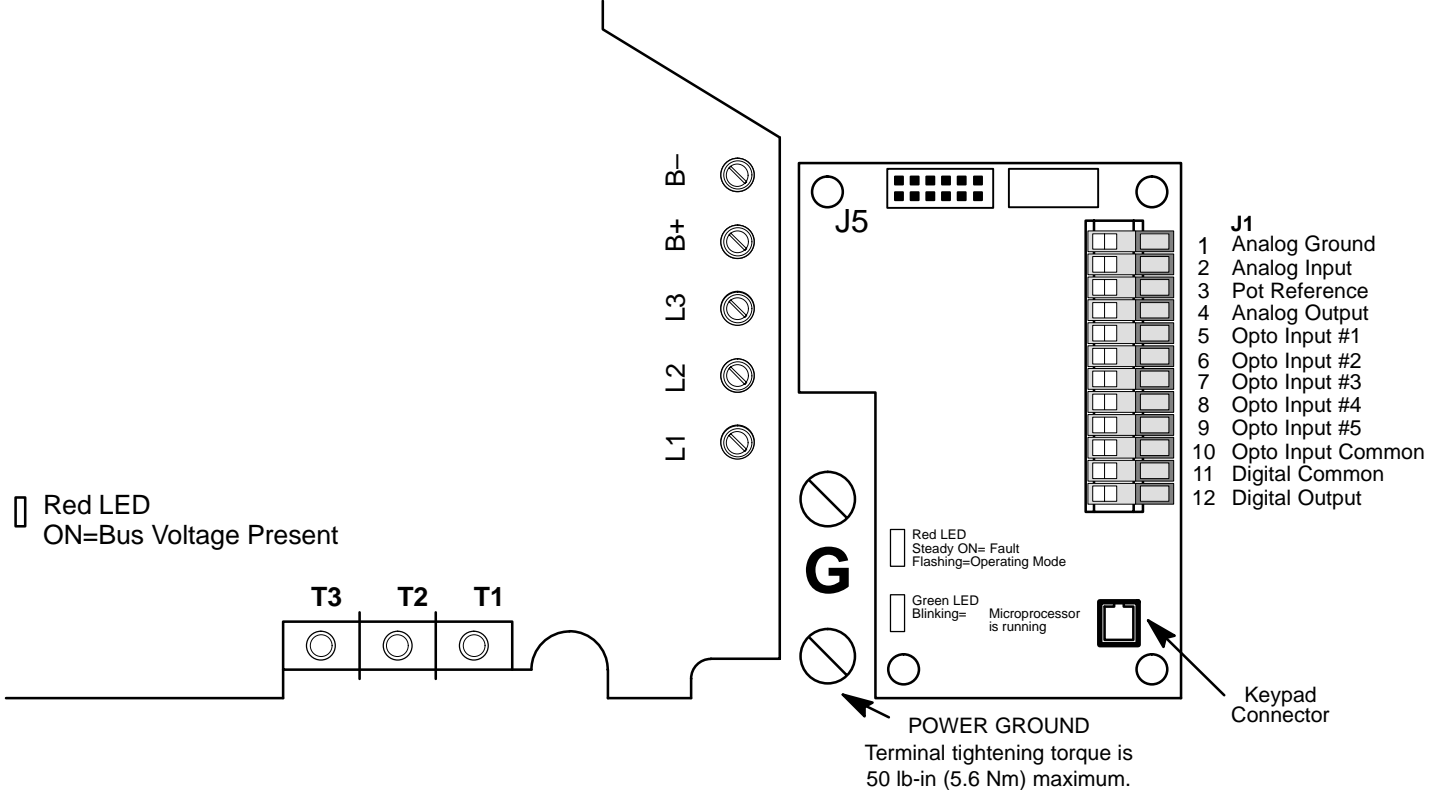

Figure 3-2 Baldor SmartMotor™ 36/37 Frame Connections



Analog Input and Output

Analog Input

An analog input is available at J1-1, J1-2 and J1-3. A potentiometer value of 5k Ω or 10k Ω , 0.5 watts may be used as a speed command. See Figure 3-3.

When using a potentiometer as the speed command, the ANA CMD Select parameter of the Level 1 Input block must be set to "Potentiometer".

When using a potentiometer as the process feedback, the Level 2 Process Control block Process Feedback parameter must be set to "Potentiometer".

Note: A 0-5VDC, 0-10VDC, 4 to 20mA or 0 to 20mA speed command signal may be connected across J1-1 and J1-2 instead of a potentiometer. The Level 1 Input block ANA CMD Select parameter (or the Level 2 Process Control block Process Feedback parameter) must be set to the appropriate value. See Figure 3-4.

Figure 3-3 Analog Potentiometer Input

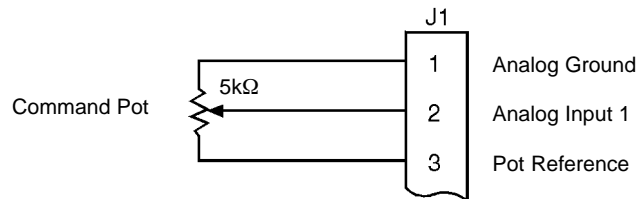
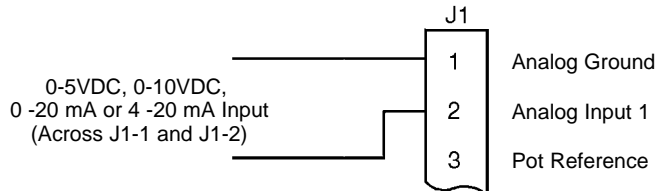

Figure 3-4 Analog Voltage or Current Input



Analog Output

One programmable analog output is provided at J1-4. See Figure 3-5. The return for this output is J1-1 analog ground. This output is scaled 0-5VDC / 0-10 VDC (1mA maximum output current) and can be used to provide real-time status of various control conditions. The Analog Output condition is programmed in the Level 1 Output block Analog OUT#1 parameter.

Figure 3-5 Analog Output Connection

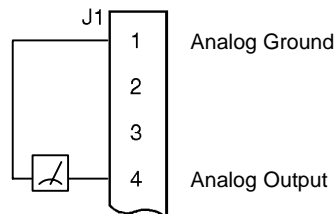

External Trip Input

Terminal J1-9 is available for connection to a normally closed thermostat or overload relay in several operating modes (Keypad, 2 Wire/Trip, 3 Wire/Trip, Profile Run Local, PID and PID:Stop). The thermostat or overload relay should be a dry contact type with no power available from the contact. If the motor thermostat or overload relay activates (opens) the control will automatically shut down and give an External Trip fault. See Figure 3-6.

Note: Do not run these wires in the same conduit as the AC power wires.

To activate the External Trip input, the Level 2 Protection Block External Trip parameter must be set to "ON".

Figure 3-6 External Trip Input

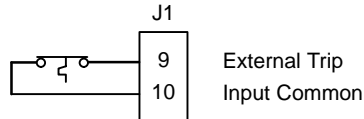

Opto Isolated Inputs and Output

Opto-isolated Inputs

Five Opto Isolated inputs are provided. Contact closure to the Input Common at J1-10 activates the input. The connections are shown in Figure 3-7.

The Opto Input mode is programmed in the Level 1 Input block Operating mode parameter.

Figure 3-7 Opto Input Configurations

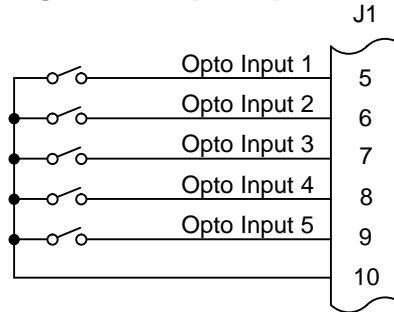

Opto-Isolated Output

One programmable Opto-isolated output is available at terminals J1-12 (J1-11 Common). The connections are shown in Figure 3-8. It may be configured for sinking or sourcing 60 mA. The maximum voltage from opto output to common when active is 1.0 VDC (TTL compatible).

If the opto output is used to directly drive a relay, a flyback diode rated at 1A, 100 V minimum (1N4002) should be connected across the relay coil.

The Opto Output condition is programmed in the Level 1 Output block Opto Output #1 parameter.

Figure 3-8 Opto-isolated Output Configurations

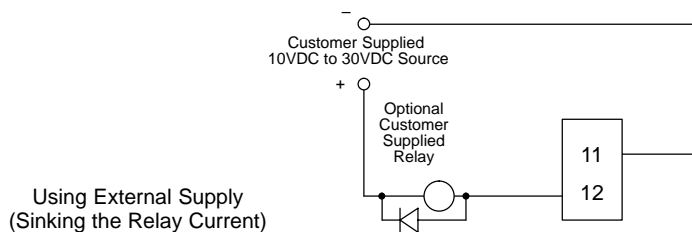

Operating Mode & Connection Diagram Examples

Several operating modes are available. These operating modes define the basic drive connections and the operation of the input and output terminals. These operating modes are selected by the Level 1 Input Block Operating Mode parameter.

Available operating modes include:

Note: Contact Baldor factory to change operating modes from the terminal strip.

- Keypad (Figure 3-9)
- 2 Wire, 7 Speed (Figure 3-10)
- 2 Wire, Trip (Figure 3-11)
- 2 Wire, 3 Speed (Figure 3-12)
- 3 Wire, 3 Speed (Figure 3-13)
- 3 Wire, Trip (Figure 3-14)
- 2 Wire, Electronic Pot (Figure 3-15)
- 3 Wire, Electronic Pot (Figure 3-16)
- Profile Run Remote (Figure 3-17)
- Profile Run Local (Figure 3-18)
- PID Mode (Figure 3-19)
- PID:Stop-Mode (Figure 3-20)

Keypad Operating Mode

Figure 3-9 Keypad Operating Mode

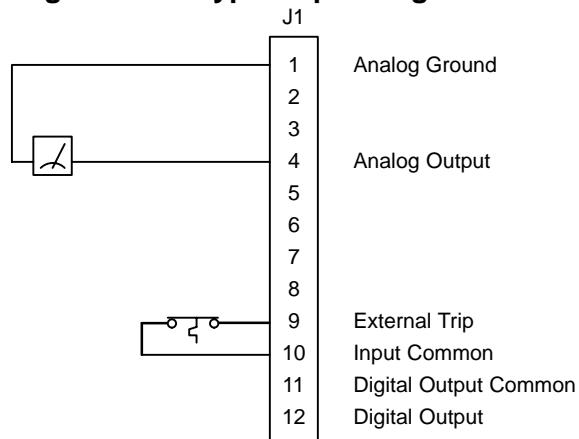

- J1-9 If J1-9 is connected, you must set Level 2 Protection block, External Trip to "ON" to activate the opto input.
CLOSED allows normal control operation.
OPEN causes an external trip fault. The control will disable and the motor coasts to a stop. An external trip fault is displayed (also logged in the fault log).

#1, 2 Wire 7 Speed Operating Mode

Figure 3-10 2 Wire 7 Speed Operating Mode

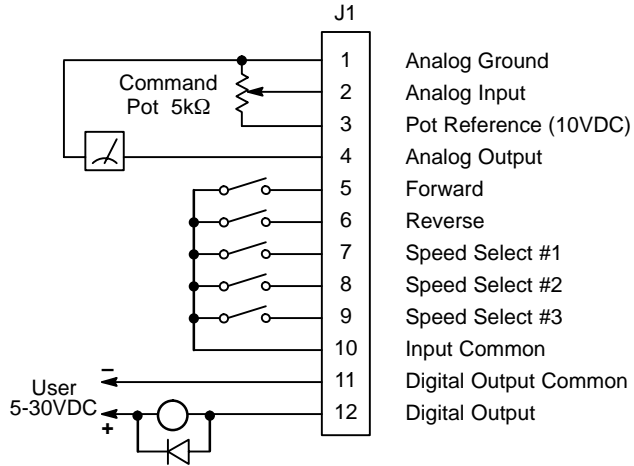

- J1-5 CLOSED operates the motor in the forward direction.
- J1-6 CLOSED operates the motor in the reverse direction.
- J1-7 Speed Select (See Table 3-2).
- J1-8 Speed Select (See Table 3-2).
- J1-9 Speed Select (See Table 3-2).

Note: For modes without a Fault Reset input, a fault can be cleared if Forward and Reverse switches are simultaneously closed and held for 2 seconds.

Note: The Analog Input (J1-2 & J1-1) is selected if all switches are open.

Table 3-2 Switch Truth Table for 2 Wire 7 Speed Mode

Function	J1-7	J1-8	J1-9
Analog Input	Open	Open	Open
Preset Speed #1	Closed	Open	Open
Preset Speed #2	Closed	Closed	Open
Preset Speed #3	Closed	Closed	Closed
Preset Speed #4	Closed	Open	Closed
Preset Speed #5	Open	Open	Closed
Preset Speed #6	Open	Closed	Closed
Preset Speed #7	Open	Closed	Open

#2, 2 Wire External Trip Operating Mode

Figure 3-11 2 Wire External Trip Operating Mode

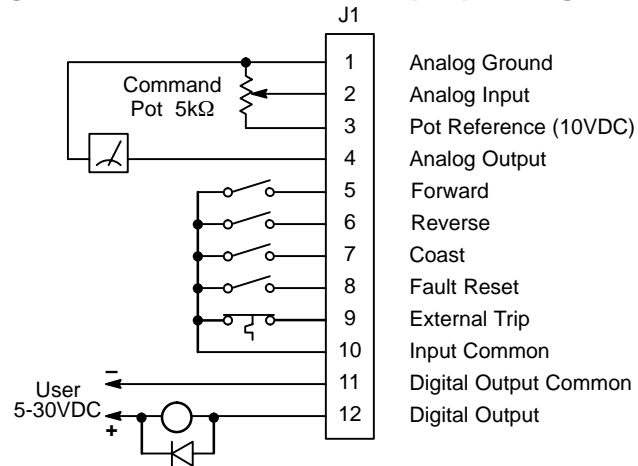

- J1-5 CLOSED operates the motor in the forward direction.
- J1-6 CLOSED operates the motor in the reverse direction.
- J1-7 CLOSED allows motor to coast (no braking).
- J1-8 CLOSED to reset fault condition.
- J1-9 If J1-9 is connected, you must set Level 2 Protection block, External Trip to "ON" to activate the opto input.
CLOSED allows normal control operation.
OPEN causes an external trip fault. The control will disable and the motor coasts to a stop. An external trip fault is displayed (also logged in the fault log).

#3, 2 Wire 3 Speed Operating Mode

Figure 3-12 2 Wire 3 Speed Operating Mode

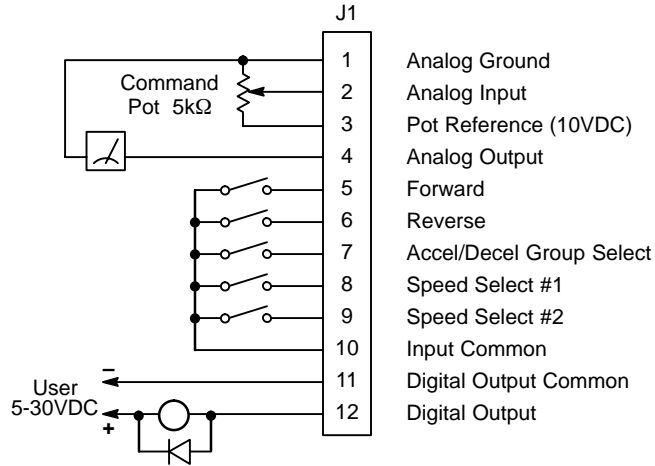

- J1-5 CLOSED operates the motor in the forward direction.
- J1-6 CLOSED operates the motor in the reverse direction.
- J1-7 CLOSED selects Accel/Decel group #2.
OPENED selects Accel/Decel group #1.
- J1-8 Speed Select (See Table 3-3).
- J1-9 Speed Select (See Table 3-3).

Note: For modes without a Fault Reset input, a fault can be cleared if Forward and Reverse switches are simultaneously closed and held for 2 seconds.

Note: The Analog Input (J1-2 & J1-1) is selected if all switches are open.

Table 3-3 Switch Truth Table for 2 Wire 3 Speed Mode

Function	J1-8	J1-9
Analog Input	Open	Open
Preset Speed #1	Closed	Open
Preset Speed #2	Closed	Closed
Preset Speed #3	Open	Closed

#4, 3 Wire 3 Speed Operating Mode

Figure 3-13 3 Wire 3 Speed Operating Mode

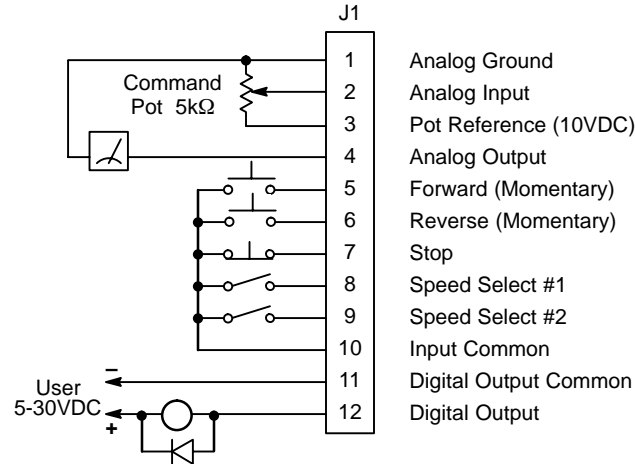

- J1-5 Momentary CLOSED operates the motor in the forward direction.
- J1-6 Momentary CLOSED operates the motor in the reverse direction.
- J1-7 When OPEN commands motor to stop.
- J1-8 Speed Select (See Table 3-4)
- J1-9 Speed Select (See Table 3-4)

Note: For modes without a Fault Reset input, a fault can be cleared if Forward and Reverse switches are simultaneously closed and held for 2 seconds.

Note: The Analog Input (J1-2 & J1-1) is selected if all switches are open.

Table 3-4 Switch Truth Table for 3 Wire 3 Speed Mode

Function	J1-8	J1-9
Analog Input	Open	Open
Preset Speed #1	Closed	Open
Preset Speed #2	Closed	Closed
Preset Speed #3	Open	Closed

#5, 3 Wire External Trip Operating Mode

Figure 3-14 3 Wire External Trip Operating Mode

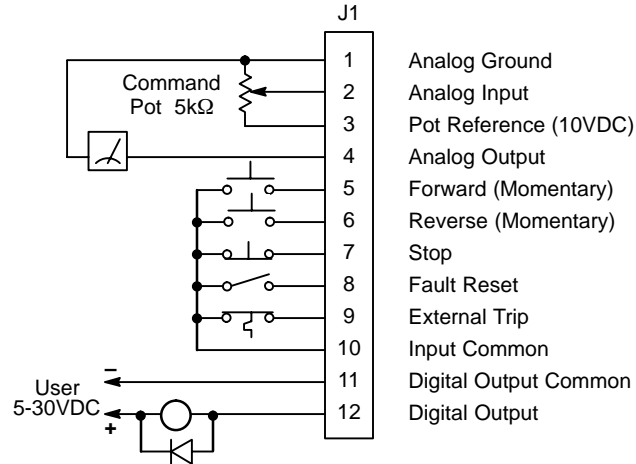

- J1-5 Momentary CLOSED operates the motor in the forward direction.
- J1-6 Momentary CLOSED operates the motor in the reverse direction.
- J1-7 When OPEN commands motor to stop.
- J1-8 CLOSED to reset fault condition.
- J1-9 If J1-9 is connected, you must set Level 2 Protection block, External Trip to "ON" to activate the opto input.
CLOSED allows normal control operation.
OPEN causes an external trip fault. The control will disable and the motor coasts to a stop. An external trip fault is displayed (also logged in the fault log).

#6, 2 Wire Electronic Pot Operating Mode

Figure 3-15 2 Wire Electronic Pot Operating Mode

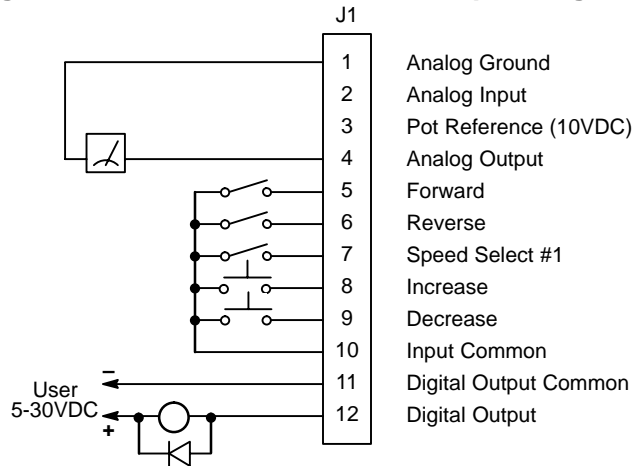

- J1-5 CLOSED operates the motor in the forward direction.
- J1-6 CLOSED operates the motor in the reverse direction.
- J1-7 OPENED selects Electronic Potentiometer
CLOSED selects Preset Speed #1 (See Table 3-5)
- J1-8 Momentary CLOSED increase motor speed while contact is closed.
- J1-9 Momentary CLOSED decrease motor speed while contact is closed.

Note: For modes without a fault reset input, a fault can be cleared if forward and reverse switches are simultaneously closed and held for 2 seconds.

Table 3-5 Switch Truth Table for 2 Wire Electronic Pot Mode

Function	J1-7
Electronic Potentiometer (EPOT)	Open
Preset Speed #1	Closed

#7, 3 Wire, Electronic Pot Operating Mode

Figure 3-16 3 Wire, Electronic Pot Operating Mode

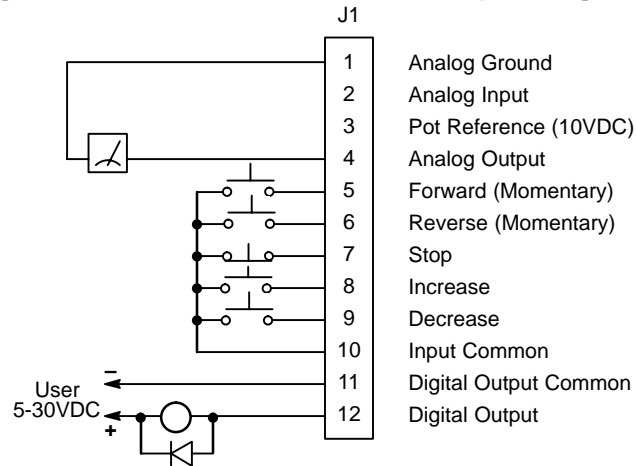

- J1-5 Momentary CLOSED operates the motor in the forward direction.
- J1-6 Momentary CLOSED operates the motor in the reverse direction.
- J1-7 When OPEN commands motor to stop.
- J1-8 Momentary CLOSED increase motor speed while contact is closed.
- J1-9 Momentary CLOSED decrease motor speed while contact is closed.

Note: For modes without a Fault Reset input, a fault can be cleared if Forward and Reverse switches are simultaneously closed and held for 2 seconds.

Profile Run Remote Operating Mode

Figure 3-17 Profile Run Remote Operating Mode

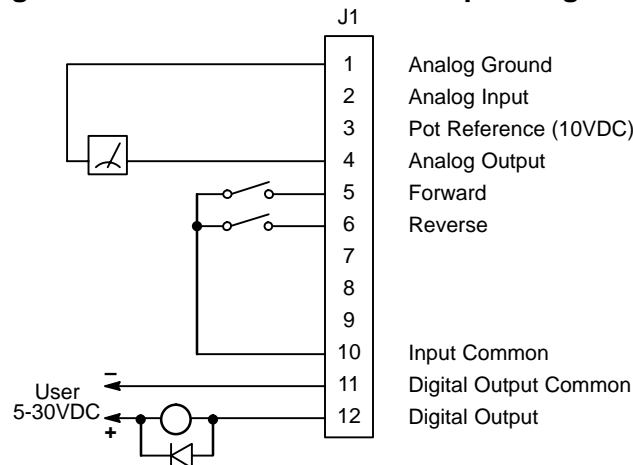

- J1-5 CLOSED allows the motor to continue the profile. When closed, the profile will resume in the direction and speed of the profile (may be forward or reverse).
- J1-6 CLOSED allows the motor to continue the profile. When closed, the profile will resume in the direction and speed of the profile (may be forward or reverse).

Note: For modes without a Fault Reset input, a fault can be cleared if Forward and Reverse switches are simultaneously closed and held for 2 seconds.

Profile Run Local Operating Mode

Figure 3-18 Profile Run Local Operating Mode

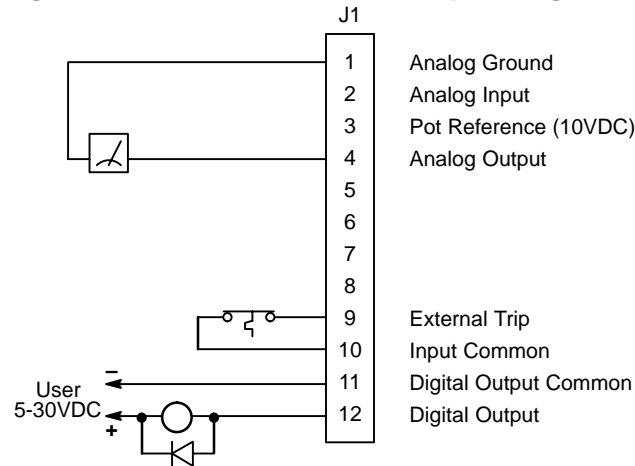

- J1-9 If J1-9 is connected, you must set Level 2 Protection block, External Trip to “ON” to activate the opto input.
 CLOSED allows normal control operation.
 OPEN causes an external trip fault. The control will disable and the motor coasts to a stop. An external trip fault is displayed (also logged in the fault log).

Analog and Digital outputs are active but operation is controlled by the keypad in this mode. No input switches except J1-9 are recognized.

PID Operating Mode

Figure 3-19 PID Mode

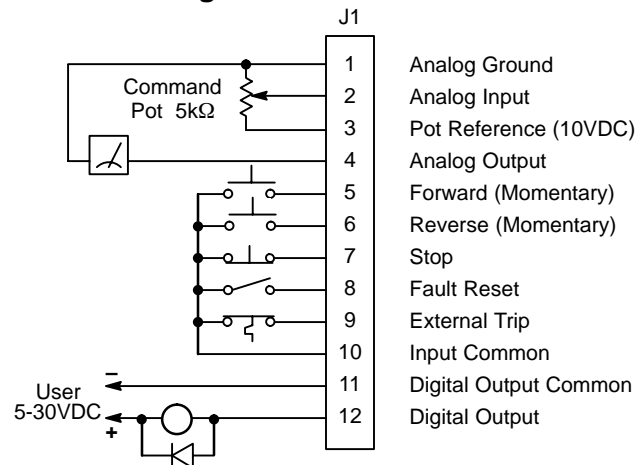

- J1-5 Momentary CLOSED operates the motor in the forward direction.
 J1-6 Momentary CLOSED operates the motor in the reverse direction.
 J1-7 When OPEN commands motor to stop.
 J1-8 CLOSED to reset fault condition.
 J1-9 If J1-9 is connected, you must set Level 2 Protection block, External Trip to “ON” to activate the opto input.
 CLOSED allows normal control operation.
 OPEN causes an external trip fault. The control will disable and the motor coasts to a stop. An external trip fault is displayed (also logged in the fault log).

PID:Stop-Mode

Figure 3-20 PID:Stop-Mode

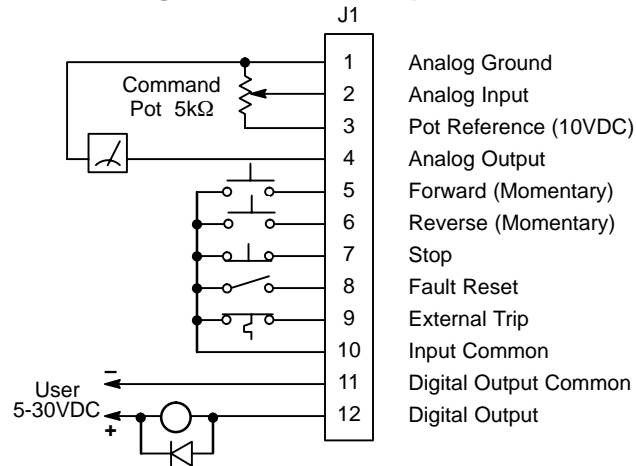

- J1-5 Momentary CLOSED operates the motor in the forward direction.
- J1-6 Momentary CLOSED operates the motor in the reverse direction.
- J1-7 When OPEN commands motor to stop.
- J1-8 CLOSED to reset fault condition.
- J1-9 If J1-9 is connected, you must set Level 2 Protection block, External Trip to “ON” to activate the opto input.
CLOSED allows normal control operation.
OPEN causes an external trip fault. The control will disable and the motor coasts to a stop. An external trip fault is displayed (also logged in the fault log).

Pre-Operation Checklist

Check of Electrical Items

1. Verify AC line voltage at source matches the SmartMotor rating.
2. Inspect all power connections for accuracy, workmanship, tightness and compliance to codes.
3. Verify SmartMotor is grounded to earth ground.
4. Check all signal wiring for accuracy.
5. Be certain all brake coils, contactors and relay coils have noise suppression. This should be an R-C filter for AC coils and reverse polarity diodes for DC coils. MOV type transient suppression is not adequate.

Check of Motor and Coupling

1. Verify freedom of motion of the motor shaft.
2. Verify that motor coupling is tight without backlash.
3. Verify the holding brakes, if any, are properly adjusted to fully release and set to the desired torque value.

Minimum Required Parameter Settings and Control Set-up Checklist

If you are familiar with programming Baldor controls continue with the following steps. If not, proceed to the programming section of this manual before applying power to the drive.

⚠ WARNING: Make sure that unexpected operation of the motor shaft during start up will not cause injury to personnel or damage to equipment.

Note: This list is the minimum program parameters required for operation of the control for initial start-up.

1. Be sure drive operation is terminated and secured.
2. Remove all power sources from the motor. Wait at least 5 minutes before proceeding to step 3.
3. Remove cover.
4. Connect the optional Keypad to the Keypad Connector (Figure 3-1). Route the keypad wires through the conduit to motor case.
5. Install the control cover.
6. Apply power to the SmartMotor.
7. Set the operating mode at the Level 1 Input block Operating Mode parameter.
8. Set the desired minimum output frequency by setting the Min Output Freq parameter in the Level 2 Output Limits block.
9. Set the desired maximum output frequency by setting the Max Output Freq parameter in the Level 2 Output Limits block.
10. If the desired peak current limit is different than presently set the PK Current Limit parameter in the Level 2 Output Limits block.
11. If using an external analog command, check ANA CMD Select parameter to verify the SmartMotor is ready to accept your analog command signal.
12. Set the desired Volts/Hertz ratio by setting the V/HZ Profile Parameter in the Level 2 V/HZ and Boost Block.
13. If the load is a high initial starting torque type, the Torque Boost parameter in the Level 1 V/HZ and Boost Block may need to be increased. Also, the ACCEL TIME #1 parameter in the Level 1 ACCEL/DECEL Rate block may need to be increased.
14. Set the date and time parameter in the Diagnostic Info area.
15. Select and program additional parameters to suit your application.

Section 4

Programming & Operation

Overview

The Baldor SmartMotor™ programming and operation is done with simple keystrokes on the keypad. The keypad is used to program the control parameters and to operate the motor when programmed for the Keypad operating mode. The Keypad Display is used to monitor the status and outputs of the control.

Figure 4-1 Keypad

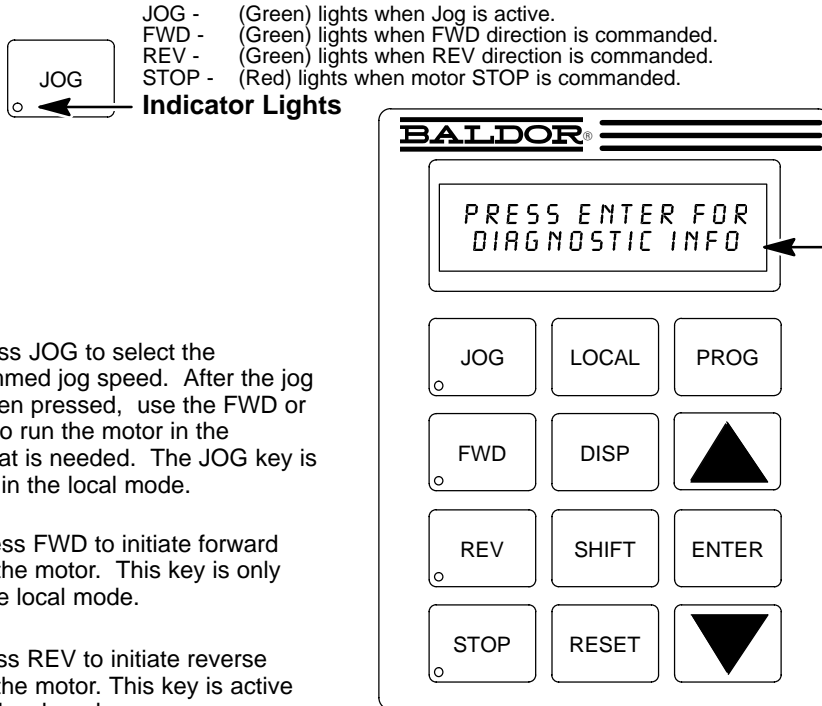

JOG - Press JOG to select the preprogrammed jog speed. After the jog key has been pressed, use the FWD or REV keys to run the motor in the direction that is needed. The JOG key is only active in the local mode.

FWD - Press FWD to initiate forward rotation of the motor. This key is only active in the local mode.

REV - Press REV to initiate reverse rotation of the motor. This key is active only in the local mode.

STOP - Press STOP to initiate a stop sequence. Depending on the setup of the control, the motor will either ramp or coast to a stop. This key is operational in all modes of operation unless it has been disabled by the Keypad Stop parameter in the Keypad (programming) Setup Block.

Note: If the control is operating in a remote mode and the stop key is pressed the control will change to the local mode when the stop command is initiated. to resume operation in the remote mode, press the LOCAL key.

LOCAL - Press LOCAL to change from remote to local (keypad) or local to remote operation. When the control is in the local mode all other external commands to the J1 terminal strip will be ignored with the exception of the external trip input.

DISP - Press DISP to return to display mode from programming mode. Provides operational status and advances to the next menu item. When in the program mode the DISP key is used to return to the display mode.

SHIFT - Press SHIFT in the program mode to control cursor movement. Pressing the SHIFT key once moves the blinking cursor one character position to the right. While in program mode, a parameter value may be reset to the factory preset value by pressing the SHIFT key until the arrow symbols at the far left of the keypad display are flashing, then press an arrow key. In the display mode the SHIFT key is used to adjust the keypad contrast.

RESET - Press RESET to clear all fault messages (in local or remote modes). Can also be used to return to the top of the block programming menu without saving any parameter value changes.

Keypad Display - Displays status information during Local or Remote operation. It also displays information during parameter setup and examination of the Fault Log.

PROG - Press PROG to enter the program mode. While in the program mode the ENTER key is used to edit a parameter setting.

▲ - (UP Arrow)
Press ▲ to change the value of the parameter being displayed. Pressing ▲ increments the value to the next greater value. Also, when the fault log or parameter list is displayed, the ▲ key will scroll upward through the list. In the local mode pressing the ▲ key will increase motor speed to the next greater value.

ENTER - Press ENTER to save parameter value changes and move back to the previous level in the programming menu. In the display mode the ENTER key is used to directly set the local speed reference. It is also used to select other operations when prompted by the keypad display.

▼ - (Down Arrow)
Press ▼ to change the value of the parameter being displayed. Pressing ▼ decrements the value to the next lesser value. Also, when the fault log or parameter list is displayed, the ▼ key will scroll downward through the list. In the local mode pressing the ▼ key will decrease motor speed to the next lesser value.

Display Mode

During normal operation the controller is in the DISPLAY MODE and the keypad displays the status of the control. When AC power is applied to the control, the keypad should display the status of the control. There are several output status values that can be monitored. When the control is in the DISPLAY MODE the information appears as follows:



* If the Level 1 Input block, Operating Mode parameter is set to "Profile Run", the display will change as follows:

Local Mode = LOCA or LCA
Remote Mode = REMA or RMA

In this example, the Control Operation would display "LOCA".

In addition, the DISPLAY MODE offers a combined display that gives the value of all output conditions simultaneously. The DISPLAY MODE also gives the user the ability to view diagnostic information and the FAULT LOG.

If there is no display visible, check to make sure that the brightness and contrast settings for the keypad display are correctly set. Use the following procedure to adjust the brightness and contrast of the display:

Adjusting Display Contrast (Contrast may be adjusted in display mode when motor is stopped or is running)

Action	Description	Display	Comments
Apply Power	No visible display		
Press DISP Key	Places control in display mode		
Press SHIFT	Allows display contrast adjustment		
Press ▲ or ▼ Key	Adjusts display intensity	ADJUST CONTRAST ⬇ (ENTER) TO SAVE	
Press ENTER	Saves level of contrast and exits to display mode	STOP FREQUENCY LOCAL 0.0 HZ	Typical display

Display Screens

Action	Description	Display	Comments	
Apply Power		INITIALIZING KEYPAD V1.01	Logo display for 5 seconds.	
	Display mode showing output frequency (Local Mode) ¹	STOP FREQUENCY LOCAL 0.0 HZ	No faults present. Local keypad mode. If in remote/serial mode, press local for this display.	
Press DISP key	Display mode showing motor speed (based on output frequency).	STOP MOTOR SPEED LOCAL 0 RPM		
Press DISP key	Display mode showing output current.	STOP CURRENT OUT LOCAL 0.0 A		
Press DISP key	Display mode showing output voltage.	STOP VOLTAGE OUT LOCAL 0 V		
Press DISP key	Display mode showing output voltage, current, frequency and motor RPM.	STP 0V 0 RPM LOC 0.0A 0.0 HZ		
Press DISP key	Fault Log entry point. To skip and display next screen, press DISP.	PRESS ENTER FOR FAULT LOG		Press ENTER to access the fault log.
Press DISP key	Diagnostic information entry point. Press DISP to continue to next display screen.	PRESS ENTER FOR DIAGNOSTIC INFO		Press ENTER to access diagnostic information.
Press DISP key	Modified parameter list entry point. To skip and display next screen, press DISP.	PRESS ENTER FOR MODIFIED PARAMS		Press ENTER to access the list of parameters modified from the factory set values.
Press DISP key	Speed command entry point. To skip and display next screen, press DISP.	PRESS ENTER FOR LOCAL SPEED REF		Press ENTER to access the speed command entry point.

¹ In Auto mode, the display would be as follows:

Action	Description	Display	Comments
	Display mode showing output frequency (Profile Run) Level 1 Input block, Operating Mode set to "PROF RUN-LOC"	STP 05 0CY LOCAL S#1 60.0HZ	No faults present. Local keypad mode. If in remote/serial mode, press local for this display.

Seconds remaining in the present speed of the profile

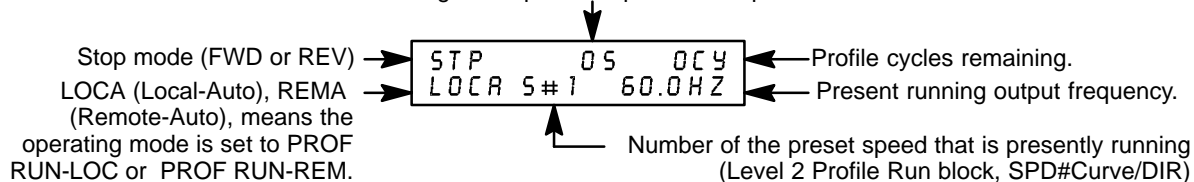

Diagnostic Screens

Action	Description	Display	Comments
Apply Power		<pre>INITIALIZING KEYPAD V1.01</pre>	Logo display for 5 seconds.
	Display mode showing output frequency (Local Mode) \square	<pre>STOP FREQUENCY LOCAL 0.0 HZ</pre>	No faults present. Local keypad mode. If in remote/serial mode, press local for this display.
Press DISP key 6 times	Scroll to diagnostic info block.	<pre>PRESS ENTER FOR DIAGNOSTIC INFO</pre>	Press ENTER to view diagnostic information if desired.
Press ENTER key	Access diagnostic information.	<pre>STOP FREQ REF LOCAL 2.0 HZ</pre>	
Press DISP key	Display mode showing control temperature.	<pre>STOP CONTROL TEMP LOCAL 25.0° C</pre>	Displays operating temperature in degrees C.
Press DISP key	Display mode showing bus voltage.	<pre>STOP BUS VOLTAGE LOCAL 321V</pre>	
Press DISP key	Display mode showing PWM Frequency.	<pre>STOP PWM FREQ LOCAL 2497 HZ</pre>	
Press DISP key	Display mode showing % overload current remaining.	<pre>STOP OVRLD LEFT LOCAL 100.00%</pre>	
Press DISP key	Display mode showing real time opto inputs & outputs states. (0=Open, 1=Closed)	<pre>DIGITAL I/O 00000 0</pre>	Opto Inputs states (Left); Opto Outputs states (Right).
Press DISP key	Display mode showing present date and time.	<pre>ENTER TO SET 12APR98 15:25:30</pre>	HR.MIN.SEC format.
Press DISP key	Display operating zone with rated HP and input voltage (for the operating zone) and control type.	<pre>1 HP STD CT 230V SMARTMOTOR</pre>	
Press DISP key	Display mode showing expansion board installed.	<pre>EXPANSION BOARD NOT INSTALLED</pre>	
Press DISP key	Display mode showing software version and revision installed in the control.	<pre>FRT END: 4.00 GSM-4.0-40</pre>	
Press DISP key	Displays exit choice. Press ENTER to exit.	<pre>PRESS ENTER FOR DIAGNOSTIC EXIT</pre>	Press ENTER to exit diagnostic information.

Fault Log Access

When a fault condition occurs, motor operation stops and a fault code is displayed on the Keypad display. The control keeps a log of up to the last 31 faults. If more than 31 faults have occurred the oldest fault will be deleted from the fault log to make room for the newest fault. To access the fault log perform the following procedure:

Action	Description	Display	Comments
Apply Power		INITIALIZING KEYPAD V1.01	Logo display for 5 seconds.
	Display mode showing output frequency	STOP FREQUENCY LOCAL 0.0 HZ	Display mode.
Press DISP key	Press DISP to scroll to the Fault Log entry point.	PRESS ENTER FOR FAULT LOG	
Press ENTER key	Diagnostic information entry point. To skip and display next screen, press DISP.	EXTERNAL TRIP 12 APR 98 15:25:30	Typical display of fault, date and time of fault.
Press ▲ or ▼ key	Scroll through fault messages.	PRESS ENTER FOR EXIT FAULT LOG	If no messages, the fault log exit choice is displayed.
Press ENTER key	Return to display mode.	STOP FREQUENCY LOCAL 0.0 HZ	Display mode stop key LED is on.

Program Mode

Use the Program Mode to customize the control for a variety of applications by programming the operating parameters. From the Display Mode press the PROG key to access the Program Mode. To return to the Display Mode, press the DISP key. Note that once a parameter is selected alternately pressing the Disp and Prog keys will change between the Display Mode and the selected parameter. When a parameter is selected for programming, the keypad display provides the following information:

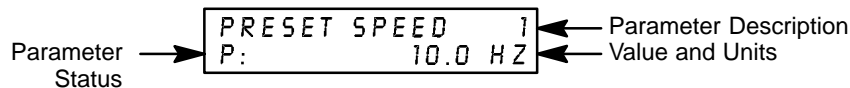

Parameter Status

- P: All programmable parameters are displayed with a P: in the lower left hand corner of the keypad display.
- V: If a parameter is displayed with a V:, the setting may be viewed but not changed while the motor is operating (or may only be changed by the factory, e.g. Motor Data).
- L: If the parameter is displayed with an L:, the setting is locked and the security access code must be entered before any changes can be made.

Parameter Blocks Access for Programming Use the following procedure to access parameter blocks to program the SmartMotor.

Action	Description	Display	Comments
Apply Power	Keypad Display shows this opening message. If no faults and programmed for LOCAL operation. If no faults and programmed for REMOTE operation. If fault is displayed, refer to the Troubleshooting section of this manual.	<pre>INITIALIZING KEYPAD V1.01</pre> <pre>STOP FREQUENCY LOCAL 0.0 HZ</pre> <pre>STOP FREQUENCY REMOTE 0.0 HZ</pre>	Logo display for 5 seconds. Display mode. Display mode.
Press PROG key		<pre>PRESS ENTER FOR PRESET SPEEDS</pre>	Press ENTER to access preset speed parameters.
Press ▲ or ▼ key	Scroll to the ACCEL/DECEL block.	<pre>PRESS ENTER FOR ACCEL/DECEL RATE</pre>	Press ENTER to access Accel and Decel rate parameters.
Press ▲ or ▼ key	Scroll to the Level 2 Block.	<pre>PRESS ENTER FOR LEVEL 2 BLOCKS</pre>	Press ENTER to access Level 2 Blocks.
Press ENTER key	Level 2 block entry point.	<pre>PRESS ENTER FOR OUTPUT LIMITS</pre>	Scroll to desired parameter value. Make changes as desired.
Press ▲ or ▼ key	Scroll to Programming Exit menu.	<pre>PRESS ENTER FOR PROGRAMMING EXIT</pre>	
Press ENTER key	Return to display mode.	<pre>STOP FREQUENCY LOCAL 0.0 HZ</pre>	

Changing Parameter Values when Security Code Not Used Use the following procedure to program or change a parameter already programmed into the SmartMotor when a security code is not being used.

This example shows how to change the operating mode from Keypad to 2 Wire/7Speed.

Action	Description	Display	Comments
Apply Power	Keypad Display shows this opening message.	INITIALIZING KEYPAD V1.01	Logo display for 5 seconds.
	If no faults and programmed for LOCAL operation.	STOP FREQUENCY LOCAL 0.0 HZ	Display mode. Stop LED on.
Press PROG key	Enter program mode.	PRESS ENTER FOR PRESET SPEEDS	
Press ▲ or ▼ key	Scroll to Level 1 Input Block.	PRESS ENTER FOR INPUT	Press ENTER to access INPUT block parameter.
Press ENTER key	Access Input Block.	OPERATING MODE P: KEYPAD	Keypad mode shown is the factory setting.
Press ENTER key	Access Operating Mode parameter.	OPERATING MODE ◄ □ KEYPAD	□ represents blinking cursor.
Press ▲ key	Scroll to make your selection.	OPERATING MODE ◄ □ #1 2WIRE/7SPD	Typical selection.
Press ENTER key	Saves selected parameter value.	OPERATING MODE ◄ □ #1 2WIRE/7SPD	
Press ▲ key	Scroll to menu exit.	PRESS ENTER FOR MENU EXIT	
Press ENTER key	Return to Input Block.	PRESS ENTER FOR INPUT	
Press DISP key	Return to Display Mode.	STOP FREQUENCY LOCAL 0.0 HZ	Typical display mode.
Press LOCAL key	Enables Remote 2 Wire/7 Speed operation.	STOP FREQUENCY REMOTE 0.0 HZ	Typical display in Remote mode.

Reset Parameters to Factory Settings Sometimes it is necessary to restore the parameter values to the factory settings. Follow this procedure to do so. Note that any of your specific application parameters will be lost when resetting the control to factory settings.

Action	Description	Display	Comments
Apply Power	Keypad Display shows this opening message.	INITIALIZING KEYPAD V1.01	Logo display for 5 seconds.
	If no faults and programmed for LOCAL operation.	STOP FREQUENCY LOCAL 0.0 HZ	Display mode. Stop LED on.
Press PROG key	Enter program mode.	PRESS ENTER FOR PRESET SPEEDS	
Press ▲ or ▼ key	Scroll to Level 2 Blocks.	PRESS ENTER FOR LEVEL 2 BLOCKS	
Press ENTER key	Select Level 2 Blocks.	PRESS ENTER FOR OUTPUT LIMITS	
Press ▲ key	Scroll to the Miscellaneous block.	PRESS ENTER FOR MISCELLANEOUS	
Press ENTER key	Select Miscellaneous block.	RESTART AUTO/MAN P: MANUAL	
Press ▲ key	Scroll to Factory Settings parameter.	FACTORY SETTINGS P: NO	
Press ENTER key	Access Factory Settings parameter.	FACTORY SETTINGS ◄ □ NO	□ represents blinking cursor.
Press ▲ key	Scroll to YES, to choose original factory settings.	FACTORY SETTINGS ◄ □ YES	
Press ENTER key	Restores factory settings.	FACTORY SETTINGS * LOADING PRESETS	***Loading Presets" is first message "Operation Done" is next.
Press ▲ key	Scroll to menu exit.	PRESS ENTER FOR MENU EXIT	
Press DISP key	Return to display mode.	STOP FREQUENCY LOCAL 0.0 HZ	Display mode. Stop LED on.

Operating the SmartMotor from the Keypad If the control is configured for remote or serial control, the LOCAL Mode must be activated before the controller may be operated from the keypad. To activate the LOCAL Mode the motor must, first be stopped using the keypad STOP key (if enabled), or by remote commands or serial commands.

Note: Pressing the keypad STOP key (if enabled) will automatically issue a motor stop command and change to LOCAL mode.





The LOCAL Mode overrides any remote or serial control inputs except for the External Trip input.

The control can operate the motor in three (3) different ways from the keypad.

1. JOG Command.
2. Speed adjustment with Keypad entered values.
3. Speed adjustment using the Keypad arrow keys.

Note: If the control has been configured for Keypad in the operating mode parameter (level 1, input block), then no other means of operation is permitted other than from the keypad.

Using the Keypad JOG Command

Action	Description	Display	Comments
Apply Power	Keypad Display shows this opening message.		Logo display for 5 seconds.
	If no faults and programmed for LOCAL operation.		Display mode. Stop LED on.
Press JOG key	Enter programmed JOG speed.		JOG key LED on.
Press and hold FWD or REV key	Move SmartMotor forward or reverse at JOG speed.		SmartMotor runs while FWD or REV key is pressed. JOG & FWD (or REV) LED's on.
Release the FWD or REV key. Press JOG key	Disables JOG mode.		JOG LED off. Stop key LED on.

Speed Adjustment from the Keypad

Action	Description	Display	Comments
Apply Power	Keypad Display shows this opening message.	<pre>INITIALIZING KEYPAD V1.01</pre>	Logo display for 5 seconds.
	If no faults and programmed for LOCAL operation.	<pre>STOP FREQUENCY LOCAL 0.0 HZ</pre>	Display mode. Stop LED on.
Press ENTER key	Select the speed parameter.	<pre>LOCAL SPEED REF 000.0 0.0 HZ</pre>	
Press SHIFT key	Move blinking cursor right one digit.	<pre>LOCAL SPEED REF 000.0 0.0 HZ</pre>	<input type="checkbox"/> represents blinking cursor.
Press ▲ key	Increase tens value by one digit.	<pre>LOCAL SPEED REF 010.0 0.0 HZ</pre>	
Press ENTER key	Save new value and return to display mode.	<pre>STOP FREQUENCY LOCAL 0.0 HZ</pre>	
Press FWD or REV key	SmartMotor runs FWD or REV at commanded speed.	<pre>FWD FREQUENCY LOCAL 10.0 HZ</pre>	FWD (REV) LED on.
Press STOP key	SmartMotor decelerates.	<pre>STOP FREQUENCY LOCAL 0.0 HZ</pre>	Display mode. Stop LED on.

Speed Adjustment Using Arrow Keys

Action	Description	Display	Comments
Apply Power	Keypad Display shows this opening message.	<pre>INITIALIZING KEYPAD V1.01</pre>	Logo display for 5 seconds.
	If no faults and programmed for LOCAL operation.	<pre>STOP FREQUENCY LOCAL 0.0 HZ</pre>	Display mode. Stop LED on.
Press FWD or REV key	SmartMotor runs FWD or REV at selected speed.	<pre>FWD FREQUENCY LOCAL 0.0 HZ</pre>	FWD key LED on.
Press ▲ key	Increase motor speed.	<pre>FWD FREQUENCY LOCAL 20.0 HZ</pre>	Display mode.
Press ▼ key	Decrease motor speed.	<pre>FWD FREQUENCY LOCAL 10.0 HZ</pre>	Display mode.
Press STOP key	SmartMotor decelerates.	<pre>STOP FREQUENCY LOCAL 0.0 HZ</pre>	Display mode. Stop LED on.
Press FWD or REV key	SmartMotor runs FWD or REV at commanded speed.	<pre>FWD FREQUENCY LOCAL 10.0 HZ</pre>	Motor runs at previously set speed.

Profile Run Changes

Action	Description	Display	Comments
Apply Power	Keypad Display shows this opening message.	<pre>INITIALIZING KEYPAD V1.01</pre>	Logo display for 5 seconds.
	Display mode showing output frequency (Local Mode)	<pre>STOP FREQUENCY LOCAL 0.0 HZ</pre>	No faults present. Local keypad mode. If in remote/serial mode, press local for this display.
Press PROG key	Enter program mode.	<pre>PRESS ENTER FOR PRESET SPEEDS</pre>	
Press ▲ or ▼ key	Scroll to Level 2 block.	<pre>PRESS ENTER FOR LEVEL 2 BLOCKS</pre>	
Press ENTER key	Access Level 2 Blocks.	<pre>PRESS ENTER FOR OUTPUT LIMITS</pre>	
Press ▼ key	Scroll to Profile Run.	<pre>PRESS ENTER FOR PROFILE RUN</pre>	
Press ENTER key	Access first screen of Profile Run.	<pre>NUMBER OF CYCLES P: 0</pre>	Press ENTER to change value. Press ▲ or ▼ key to increase or Decrease value then ENTER.
Press ▲ or ▼ key	Access RP Restart Mode screen.	<pre>RP RESTART MODE P: PROF RE-START</pre>	Press ENTER to change value. Press ▲ or ▼ key to increase or Decrease value then ENTER.
Press ▲ or ▼ key	Access Speed #1 Accel/Decel Curve and Direction screen.	<pre>SPD# 1 CURVE/DIR P: ACC/DEC#1. FWD</pre>	Press ENTER to change value. Press ▲ or ▼ key to increase or Decrease value then ENTER.
Press ▲ or ▼ key	Access speed and direction Profile Time #1 screen.	<pre>PROFILE TIME #1 P: 05</pre>	Press ENTER to change value. Press ▲ or ▼ key to increase or Decrease value then ENTER.

Continue with SPD#2–7 CURVE/DIR and Profile Time #2-7.
Press DISP when finished to return to display mode.

Security System Changes

Action	Description	Display	Comments
Apply Power	Keypad Display shows this opening message.	<pre>INITIALIZING KEYPAD V1.01</pre>	Logo display for 5 seconds.
	If no faults and programmed for LOCAL operation.	<pre>STOP FREQUENCY LOCAL 0.0 HZ</pre>	Display mode. Stop LED on.
Press PROG key	Enter program mode.	<pre>PRESS ENTER FOR PRESET SPEEDS</pre>	
Press ▲ or ▼ key	Scroll to Level 2 Blocks.	<pre>PRESS ENTER FOR LEVEL 2 BLOCKS</pre>	
Press ENTER key	Access Level 2 Blocks.	<pre>PRESS ENTER FOR OUTPUT LIMITS</pre>	
Press ▲ key	Scroll to the Security Control block.	<pre>PRESS ENTER FOR SECURITY CONTROL</pre>	
Press ENTER key	Access the Security Control block.	<pre>SECURITY STATE P: OFF</pre>	
Press ▲ key	Scroll to the Access Code parameter.	<pre>ACCESS CODE P: 9999</pre>	
Press ENTER key	The Access Code parameter can be changed.	<pre>ACCESS CODE P: 9999 9999</pre>	<input type="checkbox"/> represents blinking cursor.
Press ▼ key	Use ▼ key to change value. Example: 8999.	<pre>ACCESS CODE P: 8999 9999</pre>	<input type="checkbox"/> represents blinking cursor.
Press ENTER key	Save Access Code parameter	<pre>ACCESS CODE P: 9999</pre>	Keypad Display will not show user access code. Record its' value for future reference.
Press ▼ key	Scroll to Security State.	<pre>SECURITY STATE P: OFF</pre>	
Press ENTER key	Access Security State parameter.	<pre>SECURITY STATE P: OFF</pre>	<input type="checkbox"/> represents blinking cursor.
Press ▲ key	Select Local Security.	<pre>SECURITY STATE LOCAL SECURITY</pre>	
Press ENTER key	Save selection.	<pre>SECURITY STATE P: LOCAL SECURITY</pre>	P: will change to L: after returning to display mode for longer than the time value set in the Access Timeout parameter.
Press DISP key	Return to Display mode.	<pre>STOP FREQUENCY LOCAL 0.0 HZ</pre>	Typical display mode.

Changing Parameter Values with a Security Code in Use This example shows how to change operating modes from Keypad to #1, 2 Wire7 Speed. (Similar to previous example that did not use security code).

Action	Description	Display	Comments
Apply Power	Keypad Display shows this opening message.	<pre>INITIALIZING KEYPAD V1.01</pre>	Logo display for 5 seconds.
	If no faults and programmed for LOCAL operation.	<pre>STOP FREQUENCY LOCAL 0.0 HZ</pre>	Display mode. Stop LED on.
Press PROG key	Enter program mode.	<pre>PRESS ENTER FOR PRESET SPEEDS</pre>	
Press ▲ or ▼ key	Scroll to Input block.	<pre>PRESS ENTER FOR INPUT</pre>	
Press ENTER key	Access Input block for Operating Mode changes.	<pre>OPERATING MODE L: KEYPAD</pre>	
Press ENTER key	When security on, parameter values cannot be changed.	<pre>.. ENTER CODE .. ◇ 9999 23956</pre>	
Press ▼ key	Enter the Access Code . Example: 8999.	<pre>.. ENTER CODE .. ◇ 8999 23956</pre>	□ represents blinking cursor.
Press ENTER key		<pre>OPERATING MODE ◇ □ KEYPAD</pre>	
Press ▲ or ▼ key	Scroll to make your selection.	<pre>OPERATING MODE ◇ □ #1 2WIRE/7SPD</pre>	
Press ENTER key	Save selected parameter	<pre>OPERATING MODE ◇ □ #1 2WIRE/7SPD</pre>	
Press ▲ or ▼ key	Scroll to Menu Exit block..	<pre>PRESS ENTER FOR MENU EXIT</pre>	
Press ENTER key	Returns to Input block.	<pre>PRESS ENTER FOR INPUT</pre>	
Press DISP key	Return to Display mode.	<pre>STOP FREQUENCY LOCAL 0.0 HZ</pre>	Typical display mode.

Note: Please record your access code and store it in a safe place. If you cannot gain entry into parameter values to change a protected parameter, please contact Baldor. Be prepared to give the 5 digit code located on the lower right side of the Keypad Display at the Security Control Access Code parameter prompt.

Security System Access Timeout Parameter Change

Action	Description	Display	Comments
Apply Power	Keypad Display shows this opening message.	INITIALIZING KEYPAD V1.01	Logo display for 5 seconds.
	If no faults and programmed for LOCAL operation.	STOP FREQUENCY LOCAL 0.0 HZ	Display mode. Stop LED on.
Press PROG key	Enter program mode.	PRESS ENTER FOR PRESET SPEEDS	
Press ▲ or ▼ key	Scroll to Level 2 Blocks.	PRESS ENTER FOR LEVEL 2 BLOCKS	
Press ENTER key	Access Level 2 Blocks.	PRESS ENTER FOR OUTPUT LIMITS	
Press ▲ key	Scroll to the Security Control block.	PRESS ENTER FOR SECURITY CONTROL	
Press ENTER key	Access the Local Security block.	SECURITY STATE L:LOCAL SECURITY	
Press ▲ key	Scroll to the Access Timeout parameter.	ACCESS TIMEOUT L: 0 SEC	
Press ENTER key	Attempt to access the Access Timeout parameter.	ACCESS CODE ◇:9999 23956	<input type="checkbox"/> represents blinking cursor.
Press ▼ key	Use ▼ key to change value. Example: 8999.	.. ENTER CODE .. ◇:8999 23956	Note: Ignore the 5 digit number to the right (example: 23956).
Press ENTER key	Save Access Code parameter and allow programming of Access Timeout parameter	ACCESS TIMEOUT ◇:000 0 S	Security code entered is correct. All parameters may be changed.
Press SHIFT key.	Move cursor right one digit.	ACCESS TIMEOUT ◇:000 0 S	Access Timeout can be any value between 0 and 600 seconds.
Press ▲ key 3 times	Change the 0 to 3.	ACCESS TIMEOUT ◇:030 0 SEC	Example: 30 seconds.
Press ENTER key	Save value.	ACCESS TIMEOUT P: □ 30 S	P: indicates all parameters are unlocked. This will change to L: (locked) after 30 SEC (Access Timeout).
Press DISP key	Return to Display mode.	STOP FREQUENCY LOCAL 0.0 HZ	Typical display mode.

Note: Please record your access code and store it in a safe place. If you cannot gain entry into parameter values to change a protected parameter, please contact Baldor. Be prepared to give the 5 digit code located on the lower right side of the Keypad Display at the Security Control Access Code parameter prompt.

SmartMotor Parameters (Ver 4.0)

LEVEL 1 BLOCKS		LEVEL 2 BLOCKS	
Preset Speeds Preset Speed #1 Preset Speed #2 Preset Speed #3 Preset Speed #4 Preset Speed #5 Preset Speed #6 Preset Speed #7	Input Operating Mode ANA CMD Select ANA CMD Inverse ANA CMD Offset ANA CMD Gain ANA CMD Filter	Output Limits Min Output Freq Max Output Freq PK Current Limit PWM Frequency Custom Units Decimal Places Value At Speed Units of Measure Protection External Trip PWM vs TEMP Foldback Protect Miscellaneous Restart Auto/Man Restart Fault/Hr Restart Delay Stability Comp Factory Settings Security Control Security State Access Timeout Access Code Motor Data Motor Voltage Motor Rated Amp Motor Rated Spd Motor Rated Freq Motor Mag Amps Brake Adjust Resistor Ohms Resistor Watts DC Brake Voltage DC Brake Freq Brake On Stop Brake On Rev Stop Brake Time Brake On Start Start Brake Time	Process Control Process Feedback Process Inverse Setpoint Source Setpoint Command Setpoint Max Step At Setpoint Band Process Prop Gain Process Int Gain Process Dif Gain Min Freq Hyst Communication Protocol Baud Rate Drive Address Skip Frequency Skip Freq #1 Skip Band #1 Skip Freq #2 Skip Band #2 Skip Freq #3 Skip Band #3 Synchro Starts Synchro-Starts Sync Start Freq Sync Scan V/F Sync Setup Time Sync Scan Time Sync V/F Recover Sync Direction Profile Run Number of Cycles RP Restart Mode SPD#1 Curve/Dir Profile Time #1 SPD#2 Curve/Dir Profile Time #2 SPD#3 Curve/Dir Profile Time #3 SPD#4 Curve/Dir Profile Time #4 SPD#5 Curve/Dir Profile Time #5 SPD#6 Curve/Dir Profile Time #6 SPD#7 Curve/Dir Profile Time #7
Accel / Decel Rate Accel Time #1 Decel Time #1 S-Curve #1 Accel Time #2 Decel Time #2 S-Curve #2	Output Opto Output #1 Zero Spd Set Pt At Speed Band Set Speed Point Overload Set PT Underload Set Pt ANA Volt Range Analog Out #1 Analog Scale #1 V/HZ and Boost Ctrl Base Freq Torque Boost Dynamic Boost Slip Comp Adj V/HZ Profile Max Output Volts		
Jog Settings Jog Speed Jog Accel Time Jog Decel Time Jog S-Curve Time			
Keypad Setup Keypad Stop Key Keypad Stop Mode Keypad Run Fwd Keypad Run Rev Keypad Jog Fwd Keypad Jog Rev			

Parameter Description

The following control adjustments are available within the SmartMotor to allow custom tailoring of the drive for particular applications. Table 4-1 and 4-2 provides a description of each parameter block.

The tables in Appendix A list the location and possible values of the control adjustments.

Table 4-1 Parameter Block Definitions Level 1

Block Title	Description
PRESET SPEEDS	7 preset speeds allow selection of 7 predefined motor operating frequencies. Each speed may be selected using external switches connected to J1-7, J1-8 and J1-9. For motor operation, a motor direction command must be given along with a preset speed command.
ACCEL/DECEL RATE	<p>Accel time is the number of seconds required for the motor to increase at a linear rate from 0Hz to the frequency specified in the "Maximum Output Frequency" parameter in the Output Limits Level 2 blocks.</p> <p>Decel time is the number of seconds required for the motor to decrease at a linear rate from the frequency specified in the "Maximum Output Frequency" parameter to 0Hz.</p> <p>S-Curve is a percentage of the total Accel or Decel time and provides smooth starts and stops. Figure 4-2 illustrates how motor acceleration is changed using a 40% S-Curve. 0% represents no "S" and 100% represents full "S" with no linear segment.</p> <p>Example: Maximum Output Frequency=100 Hz; Preset Speed = 50Hz, Accel Time=10 Sec. In this example, motor will be at speed 5 seconds after commanded because preset is half the max speed.</p> <p>Note: Accel Time #1, Decel Time #1 and S-Curve #1 are related. Likewise, Accel Time #2, Decel Time #2 and S-Curve #2 are related. These relations can be used to control any Preset Speed or External Speed Command (Pot).</p> <p>Note: Since the motor uses rotor slip to produce motor torque, the motor speed may not change in a linear manner with the applied frequency. Accel, Decel and S-Curve values may be adjusted for your application.</p> <p>Note: If faults (motor trips) occur during rapid Accel or Decel, selecting an S-curve may eliminate the faults without affecting the overall ramp time.</p>
JOG SETTINGS	<p>Jog Speed changes motor speed to the preset value for jog mode. To cause motor to operate at Jog Speed the FWD or REV key must be pressed or external command Forward (J1-5) or Reverse (J1-6). The motor will run at jog speed until FWD or REV key is released or external command signal is removed.</p> <p>Jog Accel Time changes the Accel Time to a new preset value for jog mode.</p> <p>Jog Decel Time changes the Decel Time to a new preset value for jog mode.</p> <p>Jog S-Curve changes the S-Curve to a new preset value for jog mode.</p>

Figure 4-2 S-Curve Example



Table 4-1 Parameter Block Definitions Level 1 - Continued

Block Title	Description
KEYPAD SETUP	<p>Stop Key - Allows keypad “STOP” key to initiate motor stop during remote or serial operation (if Stop key is set to Remote ON). If active, pressing “STOP” automatically selects Local mode and initiates the stop command.</p> <p>Stop Mode - Selects if the Stop command causes the motor to “COAST” to a stop or “REGEN” to a stop. In REGEN, the voltage and frequency to the motor is reduced at a rate set by “Decel Time”.</p> <p>Run FWD - Makes the keypad “FWD” key active in Local mode.</p> <p>Run REV - Makes the keypad “REV” key active in Local mode.</p> <p>Jog FWD - Makes the keypad “FWD” key active in Local Jog mode.</p> <p>Jog REV - Makes the keypad “REV” key active in Local Jog mode.</p>
INPUT	<p>Operating Mode (Wiring diagrams are shown in Section 3 “Operating Mode & Connection Diagram Examples”).</p> <p>Keypad; Allows keypad commands to control motor operation.</p> <p>2WIRE/7 SPD; Allows 2 wire control and 7 preset speed settings (plus Analog Command Input).</p> <p>2WIRE/TRIP; Allows 2 wire control and External Trip input.</p> <p>2WIRE/3 SPD; Allows 2 wire control, Ramp selection, and 3 preset speed settings (plus Analog Command Input). (Ramp selects Accel/Decel/S-Curve associated group #1 or 2 preset values. Open selects group #1 and closed selects group #2).</p> <p>3WIRE/3SPD; Allows 3 wire control and 3 preset speed settings (plus Analog Command Input).</p> <p>3WIRE/TRIP; Allows 3 wire control and External Trip input.</p> <p>2WIRE/EPOT; Allows 2 wire control and “EPOT” (electronic digital pot that allows selection of Analog input or Preset Speed #1).</p> <p>3WIRE/EPOT; Allows 3 wire control and “EPOT” (electronic digital pot that allows selection of Analog input or Preset Speed #1).</p> <p>PROF RUN-REM; Profile Run; Operating in the Remote mode.</p> <p>PROF RUN-LOC; Profile Run; Operating in the Local mode.</p> <p>PID Mode; Provides a closed loop general purpose PID set point control.</p> <p>PID:Stop–Mode;</p> <p>Serial Mode; (Reserved for future use).</p> <p>Serial–PID Mode; (Reserved for future use).</p> <p>ANA CMD Select - Selects the external speed reference to be used. The most simple method of speed control is to select POTENTIOMETER and connect a 5kΩ pot to J1-1, J1-2, and J1-3. If long distance is required between the external speed control and the SmartMotor, the 0-20mA or 4-20mA selections should be considered. Current loop allows long cable lengths without attenuation of the command signal.</p> <p>ANA CMD Inverse - “Off” will cause a low input voltage (e.g. 0VDC) to be a low motor speed command and a maximum input voltage (e.g. 10VDC) to be a maximum motor speed command. “ON” will cause a low input voltage (e.g. 0VDC) to be a maximum motor speed command and a maximum input voltage (e.g. 10VDC) to be a low motor speed command.</p> <p>ANA CMD Offset - Provides an offset to the Analog Input to minimize signal drift. For example, if the minimum speed signal is 1VDC (instead of 0VDC) the ANA CMD Offset can be set to -10% so the minimum voltage input is seen by SmartMotor as 0VDC.</p> <p>ANA CMD Gain - Provides an adjustment value to scale the speed reference signal. For example, if the maximum speed signal is 9VDC (instead of 10VDC) the ANA CMD Gain can be set to 111% so the maximum voltage input is seen by SmartMotor as 10VDC.</p> <p>ANA CMD Filter - Adjusts the amount of filtering of the speed reference signal. A value of 0 provides no noise rejection but fastest response to follow the Speed Reference. A value of 6 provides maximum filtering for best noise rejection but less response to speed reference signal changes.</p>

Table 4-1 Parameter Block Definitions Level 1 - Continued

Block Title	Description																																										
OUTPUT	<p>OPTO OUTPUT #1 - One optically isolated digital output that has two operating states, ON or OFF. This output may be configured to any of 9 conditions as follows:</p> <table border="0"> <thead> <tr> <th data-bbox="342 365 456 392">Condition</th> <th data-bbox="516 365 646 392">Description</th> </tr> </thead> <tbody> <tr> <td data-bbox="342 401 428 428">Ready -</td> <td data-bbox="516 401 1105 428">Active when power is applied and no faults are present.</td> </tr> <tr> <td data-bbox="342 436 483 464">Zero Speed -</td> <td data-bbox="516 436 1469 485">Active when output frequency to motor is below the value of the “Zero Spd Set Pt” Level 1 Output parameter.</td> </tr> <tr> <td data-bbox="342 493 456 520">At Speed -</td> <td data-bbox="516 493 1446 541">Active when output frequency is within the speed range defined by the “At Speed Band” Level 1 Output parameter.</td> </tr> <tr> <td data-bbox="342 550 500 577">At Set Speed -</td> <td data-bbox="516 550 1382 598">Active when output frequency is at or above the “Set Speed Point” Level 1 Output parameter.</td> </tr> <tr> <td data-bbox="342 606 456 634">Overload -</td> <td data-bbox="516 606 1219 634">Active if motor current increases above the Overload Set Pt value.</td> </tr> <tr> <td data-bbox="342 642 472 669">Underload -</td> <td data-bbox="516 642 1235 669">Active if motor current decreases below the Underload Set Pt value.</td> </tr> <tr> <td data-bbox="342 678 509 705">Keypad Control -</td> <td data-bbox="516 678 1081 705">Active when SmartMotor is in Local keypad control.</td> </tr> <tr> <td data-bbox="342 714 412 741">Fault -</td> <td data-bbox="516 714 938 741">Active when a fault condition is present.</td> </tr> <tr> <td data-bbox="342 749 456 777">Drive On -</td> <td data-bbox="516 749 1305 777">Active when SmartMotor is “Ready” and commanded to operate the motor.</td> </tr> <tr> <td data-bbox="342 785 451 812">Reverse -</td> <td data-bbox="516 785 1105 812">Active when SmartMotor is running in reverse direction.</td> </tr> <tr> <td data-bbox="342 821 505 848">Process Error -</td> <td data-bbox="516 821 1430 869">Active when the PID control loop process is outside the range specified by the Level 2 Process Control block, AT Setpoint Band parameter.</td> </tr> </tbody> </table> <p>ZERO SPD SET PT - Sets the frequency at which the Zero Speed opto output becomes active (turns on). When the frequency (internal) is less than the ZERO SPD SET PT, the Opto Output becomes active. This is useful for when a motor brake is to interlock operation with a motor.</p> <p>AT SPEED BAND - Sets the frequency band at which the At Speed opto output becomes active (turns on). When the frequency (internal) is within the band, the Opto Output becomes active. This is useful when another machine must not start until the SmartMotor reaches operating speed.</p> <p>SET SPEED POINT - Sets the frequency at which the Set Speed opto output becomes active (turns on). When the frequency (internal) is greater than the SET SPEED POINT, the Opto Output becomes active. This is useful when another machine must not start until the SmartMotor exceeds a predetermined speed.</p> <p>OVERLOAD SET PT - Sets the value of motor current that will cause an overcurrent fault to occur.</p> <p>UNDERLOAD SET PT - Sets the value of motor current that will cause an undercurrent fault to occur.</p> <p>ANA VOLT RANGE - Sets the full scale output voltage range of the Analog Output to either 0-5 or 0-10 volts to match the scale factor of an analog device.</p> <p>ANALOG OUT#1 - One Analog output set by ANA VOLT RANGE parameter may be configured to represent any of 7 conditions as follows:</p> <table border="0"> <thead> <tr> <th data-bbox="342 1367 456 1394">Condition</th> <th data-bbox="516 1367 646 1394">Description</th> </tr> </thead> <tbody> <tr> <td data-bbox="342 1402 472 1430">Frequency -</td> <td data-bbox="516 1402 1469 1478">Represents the output frequency actually applied to the motor. 0VDC = 0Hz and 10VDC = Max Hz (slip frequency compensation not included). This is a representation of the actual output to the motor.</td> </tr> <tr> <td data-bbox="342 1486 509 1514">Freq Command -</td> <td data-bbox="516 1486 1469 1535">Represents the commanded output frequency. 0VDC = 0Hz and 10VDC = Max Hz. This is a representation of the commanded frequency, not actual motor frequency.</td> </tr> <tr> <td data-bbox="342 1543 472 1570">AC Current -</td> <td data-bbox="516 1543 1338 1591">Represents the RMS value of the output current actually applied to the motor. 0VDC = 0A_{RMS} and 10VDC = Full load current (A_{RMS}).</td> </tr> <tr> <td data-bbox="342 1600 472 1627">AC Voltage -</td> <td data-bbox="516 1600 1338 1648">Represents the RMS value of the output voltage actually applied to the motor. 0VDC = 0V_{RMS} and 10VDC = Full voltage output (V_{RMS}).</td> </tr> <tr> <td data-bbox="342 1656 488 1684">Bus Voltage -</td> <td data-bbox="516 1656 1414 1705">Represents the bus voltage (5 or 10VDC full scale). For a 230VAC drive, full scale = 400VAC input. For a 460VAC drive, full scale = 800VAC input.</td> </tr> <tr> <td data-bbox="342 1713 472 1740">ZEROCAL -</td> <td data-bbox="516 1713 1292 1740">Sets output voltage to 0VDC. Can be used to set zero on external meter.</td> </tr> <tr> <td data-bbox="342 1749 472 1776">100% CAL -</td> <td data-bbox="516 1749 1354 1776">Sets output voltage to 10VDC. Can be used to set full scale on external meter.</td> </tr> <tr> <td data-bbox="342 1785 488 1812">Temperature -</td> <td data-bbox="516 1785 1247 1812">The temperature of the control heatsink has exceeded the safe level.</td> </tr> </tbody> </table> <p>ANALOG SCALE #1 - Scale factor for the Analog Output voltage. Useful to set the zero value or full scale range for external meters.</p>	Condition	Description	Ready -	Active when power is applied and no faults are present.	Zero Speed -	Active when output frequency to motor is below the value of the “Zero Spd Set Pt” Level 1 Output parameter.	At Speed -	Active when output frequency is within the speed range defined by the “At Speed Band” Level 1 Output parameter.	At Set Speed -	Active when output frequency is at or above the “Set Speed Point” Level 1 Output parameter.	Overload -	Active if motor current increases above the Overload Set Pt value.	Underload -	Active if motor current decreases below the Underload Set Pt value.	Keypad Control -	Active when SmartMotor is in Local keypad control.	Fault -	Active when a fault condition is present.	Drive On -	Active when SmartMotor is “Ready” and commanded to operate the motor.	Reverse -	Active when SmartMotor is running in reverse direction.	Process Error -	Active when the PID control loop process is outside the range specified by the Level 2 Process Control block, AT Setpoint Band parameter.	Condition	Description	Frequency -	Represents the output frequency actually applied to the motor. 0VDC = 0Hz and 10VDC = Max Hz (slip frequency compensation not included). This is a representation of the actual output to the motor.	Freq Command -	Represents the commanded output frequency. 0VDC = 0Hz and 10VDC = Max Hz. This is a representation of the commanded frequency, not actual motor frequency.	AC Current -	Represents the RMS value of the output current actually applied to the motor. 0VDC = 0A _{RMS} and 10VDC = Full load current (A _{RMS}).	AC Voltage -	Represents the RMS value of the output voltage actually applied to the motor. 0VDC = 0V _{RMS} and 10VDC = Full voltage output (V _{RMS}).	Bus Voltage -	Represents the bus voltage (5 or 10VDC full scale). For a 230VAC drive, full scale = 400VAC input. For a 460VAC drive, full scale = 800VAC input.	ZEROCAL -	Sets output voltage to 0VDC. Can be used to set zero on external meter.	100% CAL -	Sets output voltage to 10VDC. Can be used to set full scale on external meter.	Temperature -	The temperature of the control heatsink has exceeded the safe level.
Condition	Description																																										
Ready -	Active when power is applied and no faults are present.																																										
Zero Speed -	Active when output frequency to motor is below the value of the “Zero Spd Set Pt” Level 1 Output parameter.																																										
At Speed -	Active when output frequency is within the speed range defined by the “At Speed Band” Level 1 Output parameter.																																										
At Set Speed -	Active when output frequency is at or above the “Set Speed Point” Level 1 Output parameter.																																										
Overload -	Active if motor current increases above the Overload Set Pt value.																																										
Underload -	Active if motor current decreases below the Underload Set Pt value.																																										
Keypad Control -	Active when SmartMotor is in Local keypad control.																																										
Fault -	Active when a fault condition is present.																																										
Drive On -	Active when SmartMotor is “Ready” and commanded to operate the motor.																																										
Reverse -	Active when SmartMotor is running in reverse direction.																																										
Process Error -	Active when the PID control loop process is outside the range specified by the Level 2 Process Control block, AT Setpoint Band parameter.																																										
Condition	Description																																										
Frequency -	Represents the output frequency actually applied to the motor. 0VDC = 0Hz and 10VDC = Max Hz (slip frequency compensation not included). This is a representation of the actual output to the motor.																																										
Freq Command -	Represents the commanded output frequency. 0VDC = 0Hz and 10VDC = Max Hz. This is a representation of the commanded frequency, not actual motor frequency.																																										
AC Current -	Represents the RMS value of the output current actually applied to the motor. 0VDC = 0A _{RMS} and 10VDC = Full load current (A _{RMS}).																																										
AC Voltage -	Represents the RMS value of the output voltage actually applied to the motor. 0VDC = 0V _{RMS} and 10VDC = Full voltage output (V _{RMS}).																																										
Bus Voltage -	Represents the bus voltage (5 or 10VDC full scale). For a 230VAC drive, full scale = 400VAC input. For a 460VAC drive, full scale = 800VAC input.																																										
ZEROCAL -	Sets output voltage to 0VDC. Can be used to set zero on external meter.																																										
100% CAL -	Sets output voltage to 10VDC. Can be used to set full scale on external meter.																																										
Temperature -	The temperature of the control heatsink has exceeded the safe level.																																										

⚠ Caution: Increasing the Torque Boost value may cause the motor to overheat at low speed.

Table 4-1 Parameter Block Definitions Level 1 - Continued

Block Title	Description												
V/HZ AND BOOST	<p>CTRL BASE FREQ - Sets the point on the V/Hz profile where the output voltage becomes constant regardless of further increases in output frequency. This is the output frequency that the motor changes from constant torque (or variable torque) to constant horsepower operation.</p> <p>TORQUE BOOST - This value can be changed to increase or decrease the motor starting torque, This boost adjustment changes the output voltage from the normal value (defined by the V/Hz profile) by increasing or decreasing the starting output voltage by fixed values. Increasing the boost value may cause the motor to overheat. If adjustment is required, apply maximum load to the motor shaft. Increase the Torque Boost value until the shaft just starts to rotate.</p> <p>DYNAMIC BOOST - This value can be changed to increase or decrease the motor running torque, This boost adjustment changes the output voltage from the normal value (defined by the V/Hz profile) by increasing or decreasing the output voltage per output frequency ratio.</p> <p>SLIP COMP ADJ - This parameter allows adjustment for varying load conditions during normal operation. The Slip Comp Adjustment sets the maximum variation of output frequency under varying load conditions. As the motor current increases toward 100% of Motor Rated Amps, the control will increase the output frequency to compensate for motor slip.</p> <p>V/Hz Profile - This parameter defines how much voltage will be applied to the motor in various segments of the output frequency range. The V/Hz values can adjust the amount of available torque from the motor at various speed points. 5 options are available: (See Figure 4-3)</p> <table border="1"> <thead> <tr> <th>Option</th> <th>Description</th> </tr> </thead> <tbody> <tr> <td>Linear -</td> <td>Used for constant torque applications such as conveyor systems.</td> </tr> <tr> <td>9 Points -</td> <td>Factory set for optimum motor performance.</td> </tr> <tr> <td>33% Square Law-</td> <td>Variable torque application preset profile.</td> </tr> <tr> <td>67% Square Law-</td> <td>Variable torque application preset profile.</td> </tr> <tr> <td>100% Square Law-</td> <td>Variable torque application preset profile.</td> </tr> </tbody> </table> <p>MAX Output Volts - Sets the maximum output voltage available to the motor. In some cases, this value along with the CTRL Base Frequency can be adjusted to provide a wider constant torque range or wider constant horsepower speed range than is normally available from the motor.</p>	Option	Description	Linear -	Used for constant torque applications such as conveyor systems.	9 Points -	Factory set for optimum motor performance.	33% Square Law-	Variable torque application preset profile.	67% Square Law-	Variable torque application preset profile.	100% Square Law-	Variable torque application preset profile.
Option	Description												
Linear -	Used for constant torque applications such as conveyor systems.												
9 Points -	Factory set for optimum motor performance.												
33% Square Law-	Variable torque application preset profile.												
67% Square Law-	Variable torque application preset profile.												
100% Square Law-	Variable torque application preset profile.												
LEVEL 2 BLOCK	Enters level 2 block menu												

Figure 4-3 Volts/Hz Profile
Square Law V/Hz Curve

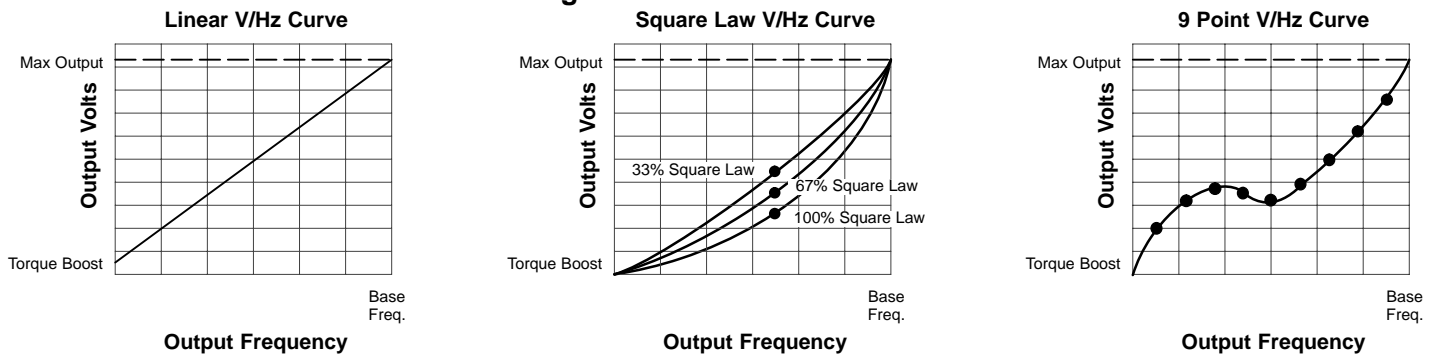

Table 4-2 Parameter Block Definitions Level 2

Block Title	Description
OUTPUT LIMITS	<p>MIN Output Frequency - Minimum value in Hz of the frequency to be applied to the motor.</p> <p>MAX Output Frequency - The maximum output frequency to the motor. This value may be exceeded slightly if Slip Compensation is active.</p> <p>PK Current Limit - The maximum output current to the motor. Values less than 100% are useful to limit motor torque that may damage driven equipment. Values of 101 to 150% can be sustained for 60 seconds and values between 151% and 200% can be sustained for 3 seconds.</p> <p>PWM Frequency - The frequency that the output transistors are switched. PWM should be as low as possible to minimize stress on the output transistors and motor windings. PWM frequency is also referred to as "Carrier" frequency.</p>
CUSTOM UNITS	<p>Decimal Places - The number of decimal places of the Output Rate display on the Keypad display. This value will be automatically reduced for large values.</p> <p>Value at Speed - The desired Output Rate value per motor RPM. The Output Rate is the number to the left of the "/" and the motor RPM is the number to the right of the "/". See also, Units of Measure.</p> <p>Units of Measure - The customized units of measure that are displayed with the Output Rate. To set the units text, first select the character by using the SHIFT key and use the ▲ and ▼ keys to scroll through the available character choices. If the desired character is not shown on the first line of the display, use the SHIFT key to move the cursor to the ▲ and ▼ arrow on the far left of the display. Once the cursor is on the Up/Down arrow special character, the arrow keys are used to select the character on the top line of the display. Then select the next character. See also, Value at Speed.</p>
PROTECTION	<p>External Trip - OFF - External Trip is Disabled. ON - If Operating Mode (Level 1 INPUT block parameter) is set to 2 Wire/Trip or 3 Wire/Trip and a normally closed contact at J1-9 is opened, an External Trip fault is generated and the SmartMotor will shut down.</p> <p>PWM vs TEMP - OFF - PWM vs TEMP disabled. ON - If temperature of the control is too great, PWM frequency will automatically be reduced.</p> <p>FOLDBACK PREVENT - OFF - FOLDBACK PREVENTION disabled. ON - Accel/Decel rate will automatically be extended to prevent overcurrent trips during rapid acceleration or overvoltage trips during rapid deceleration.</p>
MISCELLANEOUS	<p>Restart Auto/Man - Manual - If a fault occurs, the SmartMotor must be manually reset to resume operation. Automatic - If a fault occurs, the SmartMotor will automatically reset to resume operation.</p> <p>Restart Fault/Hr - The maximum number of automatic restart attempts before requiring a manual restart. After one hour without reaching the maximum number of faults or if power is turned off and on again, the fault count is reset to zero.</p> <p>Restart Delay - The amount of time allowed after a fault condition for an automatic restart to occur. Useful to allow sufficient time to clear a fault before restart is attempted.</p> <p>Factory Settings - Restores factory settings for all parameter values. Select YES and press "ENTER" key to restore factory parameter values. The keypad Display will show "Operation Done" then return to "NO" when completed.</p>

Table 4-2 Parameter Block Definitions Level 2 Continued

Block Title	Description
SECURITY CONTROL	<p>Security State - Off - No security Access Code required to change parameter values. Local - Requires security Access Code to be entered to change parameter values using the Keypad. Serial - Requires security Access Code to be entered to change parameter values using the RS 485 link. Total - Requires security Access Code to be entered to change any parameter value.</p> <p>Access Timeout - The time in seconds the security access remains enabled after leaving the programming mode. If you exit and go back into the program Mode within this time limit, the security Access Code does not have to be re-entered. This timer starts when leaving the Program Mode (by pressing Display etc.).</p> <p>Access Code - This code allows only those knowing the code to change secured parameter data. Note: Please record your access code and store it in a safe place. If you cannot gain entry into parameter values to change a protected parameter, please contact Baldor. Be prepared to give the 5 digit code located on the lower right side of the Keypad Display at the Security Control Access Code parameter prompt.</p>
MOTOR DATA	<p>Motor Voltage - The rated voltage of the motor (listed on the rating plate). This is a view only parameter and cannot be changed.</p> <p>Motor Rated Amps - The rated current of the motor (listed on the rating plate). If the motor current exceeds this value for a period of time, an Overcurrent fault will occur. This value can only be decreased from the Rated Amps value.</p> <p>Motor Rated SPD - The rated speed of the motor (listed on the rating plate). If Motor Rated SPD = 1750 RPM and Motor Rated Freq = 60 Hz, the Keypad Display will show 1750 RPM at 60 Hz but 850 RPM at 30Hz. This is a view only parameter and cannot be changed.</p> <p>Motor Rated Freq - The rated frequency of the motor (listed on the rating plate). This is a view only parameter and cannot be changed.</p> <p>Motor Mag Amps - The motor magnetizing current value (listed on the rating plate). Also called no load current. This is a view only parameter and cannot be changed.</p>
BRAKE ADJUST	<p>Resistor Ohms - The resistance value of the dynamic braking resistor in ohms.</p> <p>Resistor Watts - The power rating of the dynamic braking resistor in watts.</p> <p>DC Brake Voltage - The voltage level that will be applied to the motor windings during DC injection braking. Higher percentage braking levels will cause the motor to have more braking torque available for stopping. For applications that require frequent Stops and Starts DC injection braking will cause additional motor heating. The maximum DC voltage available =1.414(Max Output Volts*). * Max Output Volts is a Level 1 V/Hz Block parameter.</p> <p>DC Brake Freq - The output frequency at which DC injection braking begins. If this is less than the motor operating frequency, after a stop or reverse command the motor speed will decrease by the Decel Time parameter. When motor speed is reduced to a frequency equal to the DC Brake Freq DC voltage will be supplied to the motor for the amount of time specified by Stop Brake Time. If immediate DC injection braking is desired, this parameter should be set to a value greater than the motor operating frequency.</p> <p>Brake on Stop - Turns on DC injection braking after a stop command.</p> <p>Brake on Reverse - Turns on DC injection braking after a command to change motor rotation direction.</p> <p>Stop Brake Time - The amount of time the DC injection braking is applied after a stop command if Brake on Stop parameter = ON. If braking starts at a frequency less than set by the DC Brake Freq parameter, braking time is determined by the following formula:</p> $Brake\ Time = Stop\ Brake\ Time \left(\frac{Output\ Freq\ at\ Braking}{DC\ Brake\ Freq} \right)$ <p>Brake on Start - Allows DC Injection Braking at the beginning of a run command to ensure the motor shaft is not rotating. DC Injection Braking will automatically turn off and the motor will be commanded to accelerate to speed after the time specified by the Start Brake Time parameter.</p> <p>Start Brake Time - The amount of time the DC injection braking is applied if Brake on Start parameter = ON. Start Brake Time should be just long enough to ensure the motor is not rotating at start up. Additional motor heating will occur in applications that require frequent starts and stops.</p>

Table 4-2 Parameter Block Definitions Level 2 Continued

Block Title	Description
PROCESS CONTROL	<p>Process Feedback - The type of signal used for the process feedback in the PID setpoint control loop.</p> <p>Process Inverse - OFF – The process feedback signal is not inverted (no polarity change). ON – Causes the process feedback signal to be inverted. Used with reverse acting processes that use a unipolar signal such as 4-20mA. If "ON", the PID loop will see a low value of the process feedback signal as a high feedback signal and a high value of the process feedback signal as a low feedback signal.</p> <p>Setpoint Source - The source input reference signal type to which the process feedback will be compared. If "Setpoint CMD" is selected, a fixed value that is entered in the Setpoint Command parameter (of the Level 2 Process Control block) will be used.</p> <p>Setpoint Command - The setpoint value for the PID loop that the control will try to maintain. Used only when the setpoint source parameter is set to "Setpoint Command".</p> <p>Setpoint Max Step - The maximum frequency correction value to be applied to the motor (in response to the maximum process error). For example, if the max output frequency is 60 Hz, the setpoint adjustment limit is 20%, the process error is 100% and the maximum speed the motor will run in response to the setpoint feedback error is ± 12 Hz. ($60\text{Hz} \times 20\% = 12\text{Hz}$ or a total of 24 Hz total output band-width centered around the effective setpoint frequency).</p> <p>At Setpoint Band - The operating band within which the At Setpoint opto output is active (turned ON). This feature indicates when the process is within the desired setpoint range. For example, if the setpoint source is 0-10VDC and the at setpoint band value is 10%, the at setpoint opto output will turn on if the process is within ($10 \times 10\% = 1$) $\pm 1\text{VDC}$ of the setpoint.</p> <p>Process Prop Gain - Sets the PID loop proportional gain or how much adjustment to motor speed is made to bring the process to the setpoint.</p> <p>Process Int Gain - The PID loop Integral gain or how much adjustment to motor speed is made to correct for long term error.</p> <p>Process Diff Gain - The PID loop differential gain or how much adjustment to motor speed is made for short term error.</p> <p>Min Frequency Hysteresis - To prevent heat buildup within the inverter fed motor, the motor output goes to 0Hz when the process slows to the minimum speed. Before the motor speed increases from 0Hz, the process must request a speed that is greater than the Min Frequency + Min Frequency Hysteresis value (see Figure 4-4). (Min Frequency = Level 2, Output Limits, MIN Output Frequency). A setting of 0Hz disables the Minimum Frequency Hysteresis feature.</p>
COMMUNICATION	<p>Protocol - (Factory use only).</p> <p>Baud Rate - (Factory use only).</p> <p>Drive Address - (Factory use only).</p>

Figure 4-4 Minimum Frequency Hysteresis

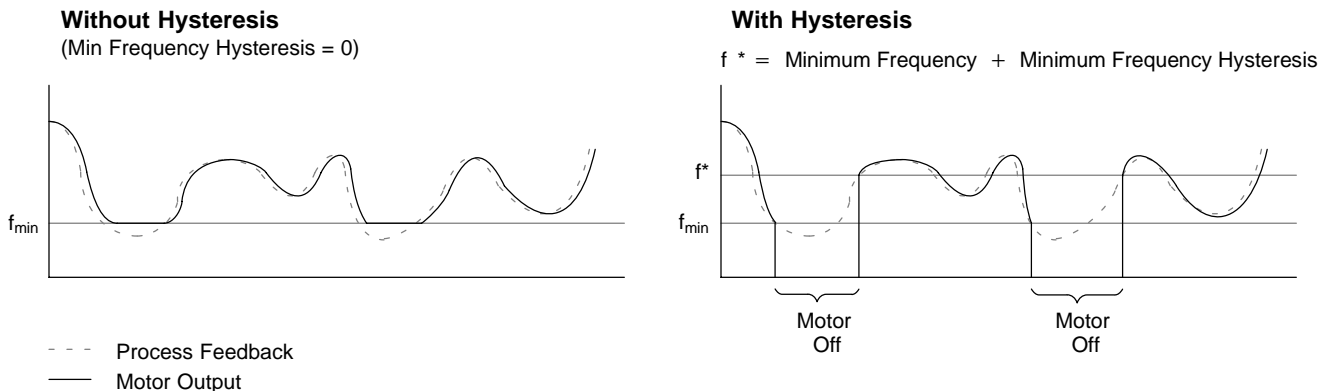

Table 4-2 Parameter Block Definitions Level 2 Continued

Block Title	Description
SKIP FREQUENCY	<p>Skip Frequency #1, #2, and #3 - Three frequency bands can be specified. Each value is the mid point of the frequency band to skip. This feature is useful to eliminate critical machine speeds that cause unwanted vibrations.</p> <p>Skip Band #1, #2, and #3 - The Skip Band value is the bandwidth of the skip frequencies. Used with the Skip Frequency parameter to completely specify the 3 bands. Example, Skip Freq = 20 Hz, Skip Band = 5 Hz.; the actual frequencies to skip are 15 Hz to 25Hz. Two additional bands may be specified.</p>
SYNCHRO STARTS	<p>Synchro-Starts - Select if the motor speed synchronization is disabled "OFF", on for automatic starts after a fault condition "Restarts Only"; or on for "All Starts" (after a fault, after loss of input power, or a run command is issued). The Synchro Start feature is desirable for applications in which the motor shaft is turning when the motor is commanded to start.</p> <p>Sync Start Freq - Set Synchro Start to begin scanning at a specified frequency or at the Max motor frequency. Scanning will start at this frequency and end at 0 Hz.</p> <p>Sync Scan V/F - Set the Synchro Start Volts/Hz ratio as a percentage of the Max Output Volts/CTRL Base Freq parameters of the Level 1 V/Hz and Boost block. The factory setting provides enough power to just magnetize the rotor and should be adequate. If too high, SmartMotor may fault on Overcurrent.</p> <p>Sync Setup Time - Sets the time allowed to ramp the output voltage from 0 volts to the voltage that corresponds to the Sync Start Freq. Only applies if Synchro Start is active. If the Synchro Start feature is not operating quickly enough, this time may be decreased. Otherwise the factory setting should be adequate.</p> <p>Sync Scan Time - Used to eliminate false Synchro Starts and is the time allowed for frequency scanning. Sets the time allowed to scan from the Sync Start Freq to 0 Hz. Should be set as great as possible to eliminate false Synchro Starts.</p> <p>Sync V/F Recover - Sets the ramp time to increase the output voltage from the voltage that corresponds to the Sync Start Freq to the normal motor output voltage. Should be low enough to minimize Synchro Start time without causing a fault on Overcurrent.</p> <p>Sync Direction - Selects if the Synchro Start will begin scanning for motor rotational frequency in forward only, reverse only, or both forward and reverse. If the application requires only one direction of motor rotation, then setting Sync Direction to that direction only will reduce detection/sync time.</p>
PROFILE RUN	<p>NUMBER OF CYCLES - A profile consists of 0 to 7 predefined run conditions and each extends for a defined number of seconds.</p> <p>RP RESTART MODE - If the profile is interrupted (lost power or stopped), Restart from beginning of profile after interrupt or Continue from point of interrupt.</p> <p>SPD#1-7 CURVE/DIR - Seven (7) conditions can be defined using ACCEL/DECEL curve 1 or 2 and FWD or REV motor shaft travel.</p> <p>PROFILE TIME #1-7 - The duration of each condition in seconds.</p>
LEVEL 1 BLOCK	Enters level 1 block menu

Section 5 Troubleshooting

Overview





The Baldor SmartMotor™ requires very little maintenance, if any, and should provide years of trouble free operation when installed and applied correctly. Occasional visual inspection should be considered to insure tight wiring connections and to avoid accumulation of any dust, dirt, or foreign debris. The SmartMotor should be physically located in such a manner as to protect the internal circuits and associated external wiring from any accumulation of moisture or other types of liquid contaminants.

Troubleshooting

Before attempting to service this equipment, all input power should be removed from the SmartMotor to avoid the possibility of electrical shock. The servicing of this equipment should be handled by a qualified electrical service technician experienced in high power electronics.

Most troubleshooting can be performed using only a digital voltmeter having an input impedance exceeding 1 megohm. In some cases, an oscilloscope with 5 MHz minimum bandwidth may be useful. Before consulting the factory, check that all power and control wiring is correct and installed per the recommendations given in this manual.

No Keypad Display - Display Contrast Adjustment The possibility exists of no display in the keypad depending upon the level of contrast for which the display is set. The following procedure provides the steps necessary to adjust the contrast of the display.

Action	Description	Display	Comments
Apply Power	No visible display.		Display mode.
Press DISP key	Ensures control in Display mode.		
Press SHIFT key	Allows display contrast adjustment.		
Press ▲ or ▼ key	Adjusts display contrast (intensity).		
Press ENTER key	Saves display contrast adjustment level and exits to display mode.		

How to Access Display Screens





Action	Description	Display	Comments	
Apply Power		<pre>INITIALIZING KEYPAD V1.01</pre>	Logo display for 5 seconds.	
	Display mode showing output frequency.	<pre>STOP FREQUENCY LOCAL 0.0 HZ</pre>	Display mode. If in REMOTE, press DISP for this display.	
Press DISP key	Display mode showing a representation of motor speed based on output frequency.	<pre>STP MOTOR SPEED LOCAL 0 RPM</pre>		
Press DISP key	Display mode showing output current.	<pre>STOP CURRENT OUT LOCAL 0.0 A</pre>		
Press DISP key	Display mode showing output voltage.	<pre>STOP VOLTAGE OUT LOCAL 0 V</pre>		
Press DISP key	Display mode showing combination of output current, voltage, frequency and motor RPM.	<pre>STP 0V 0 RPM LOC 0.0 A 0.0 HZ</pre>		
Press DISP key	Fault log entry point. Press DISP to continue to next display screen.	<pre>PRESS ENTER FOR FAULT LOG</pre>		Press ENTER to access fault log record.
Press DISP key	Diagnostic information entry point. Press DISP to continue to next display screen.	<pre>PRESS ENTER FOR DIAGNOSTIC INFO</pre>		Press ENTER to access diagnostic information.
Press DISP key	Display modified parameters entry point. Press DISP to continue to next display screen.	<pre>PRESS ENTER FOR MODIFIED PARAMS</pre>		Press ENTER to display parameters that have been changed from factory settings.
Press DISP key	Local keypad enter for speed entry point. Press DISP to continue to next display screen.	<pre>PRESS ENTER FOR LOCAL SPEED REF</pre>		

Diagnostic Information Screens

Action	Description	Display	Comments
Apply Power		INITIALIZING KEYPAD V1.01	Logo display for 5 seconds.
	Display mode showing output frequency.	STOP FREQUENCY LOCAL 0.0 HZ	Display mode. If in REMOTE, press DISP for this display.
Press DISP key	Press DISP to scroll to the Diagnostic Info menu.	PRESS ENTER FOR DIAGNOSTIC INFO	Press ENTER to access diagnostic information.
Press ENTER key	First diagnostic information display.	STOP FREQ REF LOCAL 2.0 HZ	Display of commanded output frequency.
Press DISP key		STOP CONTROL TEMP LOCAL 25.0 °C	Control heatsink temperature in °C.
Press DISP key		STOP BUS VOLTAGE LOCAL 321.7V	DC Bus voltage value.
Press DISP key		STOP PWM FREQ LOCAL 2200 HZ	Actual PWM frequency as provided to the motor.
Press DISP key		STOP OVRD LEFT LOCAL 100.0%	% of overload remaining.
Press DISP key		DIGITAL I/O 00000 1	Display of digital input and outputs states.
Press DISP key		[ENTER] TO SET 12APR98 15:25:30	Real time clock display. Press enter to change date or time.
Press DISP key		1 HP STD CT 230V SMARTMOTOR	Rated HP and voltage of motor.
Press DISP key		EXPANSION BOARD NOT INSTALLED	Displays which expansion board is installed.
Press DISP key		FRT END: 4.00 GSM-4.0-40	Software version installed in the main microprocessor.
Press ENTER key		PRESS ENTER FOR DIAGNOSTIC EXIT	Press ENTER to return to normal display mode displays.

How to Set Date and Time

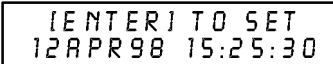
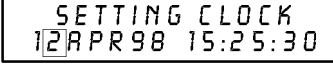
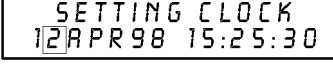
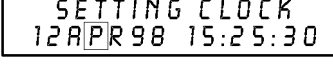
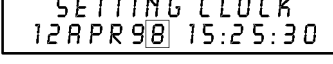
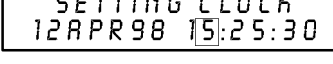
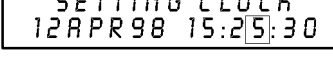
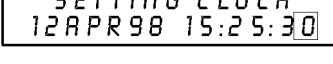
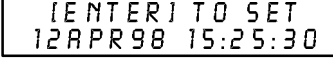
To change date and time, access the Diagnostic Info display as previously described in "Diagnostic Information Screens".

Action	Description	Display	Comments
	Diagnostic information entry point.		Press ENTER to access diagnostic information.
Press ENTER key	First diagnostic info display. Scroll to date and time display.		Press ENTER to display parameters that have been changed from factory settings.
Press DISP key	Scroll to date and time information.		
Press ENTER key	Access date and time information.		
Press ▲ or ▼ key	Change date. Press SHIFT when finished to change month.		
Press ▲ or ▼ key	Change month. Press SHIFT when finished to change year.		
Press ▲ or ▼ key	Change year. Press SHIFT when finished to change hours.		
Press ▲ or ▼ key	Change hours. Press SHIFT when finished to change minutes.		
Press ▲ or ▼ key	Change minutes. Press SHIFT when finished to change seconds.		
Press ▲ or ▼ key	Change seconds. Press ENTER when finished.		Press ENTER when finished to save date and time and exit this level.
Press ENTER key			Press ENTER to save the clock settings and exit clock setting mode.
Press DISP key	Scroll to Diagnostic Exit.		
Press ENTER key	Display mode showing output frequency.		Display mode.

How to Access the Fault Log

When a fault condition occurs, motor operation stops and a fault code is displayed on the Keypad display. The control keeps a log of the last 31 faults. To access the fault log perform the following procedure:

Action	Description	Display	Comments
Apply Power			Logo display for 5 seconds.
	Display mode showing output frequency.		Display mode.
Press DISP key	Press DISP to scroll to the Fault Log entry point.		
Press ENTER key	Displays most recent message.		
Press ▲ or ▼ key	Scroll through fault messages.		If no messages, the exit message is displayed.
Press ENTER key	Return to display mode.		

How to Clear the Fault Log Use the following procedure to clear the fault log.

Action	Description	Display	Comments
Apply Power			Logo display for 5 seconds.
	Display mode showing output frequency.		Display mode.
Press DISP key	Press DISP to scroll to the Fault Log entry point.		
Press ENTER key	Displays most recent message.		
Press SHIFT key			
Press RESET key			
Press SHIFT key			
Press ENTER key	Fault log is cleared.		No faults in fault log.
Press ▲ or ▼ key	Scroll to Fault Log Exit.		
Press ENTER key	Return to display mode.		

Restore Factory Parameter Values Sometimes it is necessary to recover the factory preset parameter values. Follow this procedure to do so. Note that any of your specific application parameters will be lost when resetting the control to factory settings.









Action	Description	Display	Comments
Apply Power	Display show opening logo.		Logo display for 5 seconds.
	Display mode showing output frequency.		Display mode.
Press PROG key			
Press ▲ or ▼ key	Scroll to the Level 2 entry point.		
Press ENTER key	Enter Level 2 Blocks.		
Press ▲ key	Scroll to Miscellaneous block.		
Press ENTER key	Enter Miscellaneous block.		
Press ▲ key	Scroll to Factory Settings parameter.		
Press ENTER key	Access Factory Settings parameters.		
Press ▲ key	Scroll to YES.		
Press ENTER key	Select YES to restore factory settings.		First displays “*Loading Presets”, then “Operation Done”.
Press ▲ key	Scroll to Menu Exit.		
Press ENTER key then press DISP key	Return to display mode.		Display mode. Stop LED on.

Table 5-1 Fault Messages

FAULT MESSAGE	DESCRIPTION
CONVERTER ERROR	Error detected in converter hardware.
CONVERTER EEPROM	Parameter Checksum failure due to corrupted data.
H/W SHUTDOWN	Hardware fault condition detected. (High/Low DC Bus, HW limits exceeded).
LEAKAGE CURRENT	Ground Fault detected by hardware (output current leakage to ground).
1 MIN TIMEOUT	Peak output current exceeded 1 Minute Rating.
3 SEC TIMEOUT	Peak output current exceeded 3 Second Rating.
DC LINK HIGH	Excessive DC Bus voltage.
DC LINK dv/dt HI	Excessive ripple on DC Bus.
DC LINK LOW	Low DC Bus voltage.
HIGH TEMPERATURE	Module heatsink over temperature.
EXTERNAL TRIP	Open or no connection between External Trip Terminals.
REGEN RES POWER	Excessive power in Dynamic Braking circuit.
DIGITAL OUT CUR	Excessive Opto Output current.
INTERNAL COM	Communication failure between the front end and motor control microcontrollers.
FAULT CODE XX	Fault code by microprocessor (2 Hexadecimal digits).
EXCESS HSD/1 MIN	Too many hardware shutdowns per 1 minute interval.
FRONT END EEPROM	EEPROM error in front end microprocessor board.
FRONT END FLASH	Error in flash memory in front end microprocessor board.
FRONT END ERROR	Error detected by front end microprocessor.
DC LINK RIPPLE	Excessive noise ripple on DC link.
OVERCURRENT #1	Motor current exceeded limits during a ramp up or ramp down.
EXCESS RESETS/HR	Resets/Hr exceeded preset limit within 1 hour.
COM ERROR LOGGED	Communication link had failure detected at start-up.
OVERCURRENT #2	Motor over current was detected.
OVERCURRENT #3	Motor over current was detected.
FRAME ERROR	Telegram buffer over run.
COMMAND ERROR	Command buffer over run.
PARAMETER ERROR	Parameter buffer over run.

Table 5-2 Troubleshooting

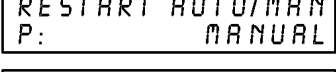
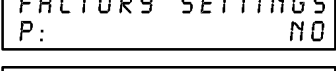
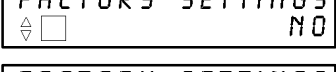
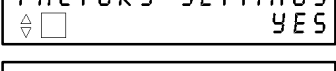
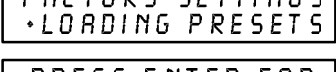
INDICATION	POSSIBLE CAUSE	CORRECTIVE ACTION
Wrong Date & Time	Improper setting.	Set Date and time in Diagnostic Info area.
	Low internal battery.	Contact service.
No Display	Lack of input voltage.	Check input power for proper voltage.
	Loose connections.	Check input power termination. Verify connection of operator keypad.
	Incorrect contrast setting.	Adjust display contrast. See Adjust Display Contrast in Sec. 4.
Motor Will Not Start	Not enough starting torque.	Increase first the torque boost setting, then dynamic boost if necessary.
	Motor overloaded.	Check for proper motor loading. Check couplings for binding. Order correct size SmartMotor.
	Control not in local mode (Keypad) or remote mode (for terminal strip).	Place control in local mode for Keypad operation. Place control in remote mode for terminal strip operation.
	Motor may be commanded to run below minimum frequency setting.	Increase speed command or decrease minimum frequency setting.
Motor Will Not Reach Maximum Speed	Maximum frequency limit set too low.	Adjust maximum output frequency setting.
	Motor overloaded.	Check for mechanical overload. If unloaded motor shaft does not rotate freely, check motor bearings.
	Improper speed command.	Verify control is receiving proper command signal at input terminals. Verify control is set to receive your speed command.
	Speed potentiometer.	Replace potentiometer.
Motor Will Not Stop Rotation	Minimum frequency limit set too high	Adjust minimum output frequency.
	Improper speed command.	Verify control is receiving proper command signal at input terminals. Verify control is set to receive your speed command.
	Speed potentiometer failure.	Replace potentiometer.
Unstable Speed (Motor Unloaded)	Unloaded motors can oscillate at their natural frequency.	Change the V/Hz Profile to 100% square law while motor shaft is unloaded. When a load is connected, use the Linear V/Hz profile.
Unstable Speed (Motor Loaded)	Oscillating load connected to motor.	Stabilize motor loading.
	Unstable input power.	Stabilize input power.
	Slip compensation set too high.	Adjust slip compensation.
Motor Runs Rough At Low Speeds (Motor Unloaded)	Unloaded motors can oscillate at their natural frequency.	Change the V/Hz Profile to 100% square law while motor shaft is unloaded. When a load is connected, use the Linear V/Hz profile.
Motor Runs Rough At Low Speeds (Motor Loaded)	Torque boost set too high.	Adjust torque boost setting.
	Misalignment of motor/load coupling.	Check coupling alignment.
	Faulty motor.	Check motor winding connections.
HW Shutdown	Fault condition detected.	Reset SmartMotor.
	Noise entering control logic circuits.	Check for proper grounding of power wiring. Verify proper shielding of signal wiring.
	Motor overloaded.	Verify sizing of SmartMotor. Reduce motor loading.
	Incorrect DC bus voltage.	Reset control. If error still exists, use the diagnostic screens and verify the bus voltage is within $\pm 5\text{VDC}$ of rating (230VAC=325VDC bus, 460VAC=650VDC bus).
	Input voltage too high.	Check input voltage. Use transformer to step down voltage. Use line reactor to minimize voltage spikes.
	Decel rate set too quickly.	Increase decel time. Add external dynamic braking module.
	Overhauling motor load.	Reduce motor load. Add external dynamic braking module.

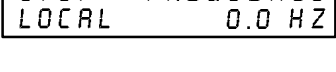
Table 5-2 Troubleshooting Continued

INDICATION	POSSIBLE CAUSE	CORRECTIVE ACTION
HW Shutdown (during Ramp up or down)	Decel times are too short. Inertia is too big for the decel time. Foldback protection is off.	Increase the decel time. If this is not possible, install dynamic brake kit. Setting Level 2 Protection block, Foldback to ON will extend the decel time to help prevent the HW shutdown fault. Depending on the inertia, the decel time may still have to be increased.
HW Shutdown or DC Link Low	Insufficient input voltage.	Verify proper input voltage. Use a transformer to step up voltage. Check power line disturbances due to starting other equipment. Monitor power line for correlation of time/date and power fluctuations. Contact power company.
DC Link High	Incorrect DC bus voltage.	In diagnostic screens check that the bus voltage is within $\pm 5VDC$ of rating (230VAC=325VDC bus, 460VAC=650VDC bus). Contact Baldor service.
DC Link Low	Low input voltage or excessive ripple on input power lines.	Reset control. If error still exists, use the diagnostic screens and check that the bus voltage is within $\pm 5VDC$ of rating (230VAC=325VDC bus, 460VAC=650VDC bus). Contact Baldor service.
DC Link dv/dt High	Excessive ripple on input power lines. Single phase input power may be insufficient for application.	Reset control. If error still exists, use the diagnostic screens and check that the bus voltage is within $\pm 5VDC$ of rating (230VAC=325VDC bus, 460VAC=650VDC bus). Contact Baldor service.
High Temperature	Motor overloaded.	Reduce motor loading. Order correct size SmartMotor.
	Ambient temperature too high.	Reduce ambient temperature. Add cooling fans or air conditioning.
	PWM vs TEMP is set to off.	Set Level 2 Protection block, PWM vs TEMP to ON. When the temperature exceeds a predetermined limit, the PWM frequency will be reduced automatically.
	Motor fan is ineffective.	Clean debris from fan and heatsink fins. Replace fan blade if necessary.
Front End EEPROM	Failure to read or write to memory.	Reset control. Reset control parameters to factory settings. Hardware failure, contact service.
Converter EEPROM	Parameter checksum failure due to corrupt data.	Reset control. Reset control parameters to factory settings. Hardware failure, contact service.
Fault Code XX	Fault detected by main microprocessor. 2 digit Hex value is also displayed.	Reset control. Reset control parameters to factory settings. Hardware failure, contact service.
Leakage Current	Output current leakage to ground.	Check motor leads and connections for grounds. Verify motor is not internally grounded.
1 Min Timeout	Peak output current exceeded 1 minute rating.	Increase PK current limit parameter setting. Check motor for overloading. Check that the Torque Boost parameter value is not set too high. Order correct size SmartMotor.
3 Sec Timeout	Peak output current exceeded 3 second rating.	Increase PK current limit parameter setting. Check motor for overloading. Check the ACCEL time and increase if necessary. Check that the Torque Boost parameter value is not set too high. Order correct size SmartMotor.
Regen Res Power	Excessive power in dynamic brake circuit.	Verify proper Ohm and Watt parameters. Increase decel time. Add/increase external dynamic braking capability.
Digital OUT CUR	Digital output is overloaded.	Be sure OPTO output current is less than 60 mA. Check relay protection diode for correct position.
Internal Com	Communication failure between the front end and motor control microcontrollers.	The green LED should blink consistently. An erratic blinking pattern might indicate noise in the communication hardware. Check input power and all wires connected to the smart motor.
Excess HSD/1 min	Too many H/W Shutdowns within 1 minute.	Check if attempting to autorestart into a load. Increase delay time of autorestart. Check load. See other H/W shutdown corrective actions.

Table 5-2 Troubleshooting Continued

INDICATION	POSSIBLE CAUSE	CORRECTIVE ACTION
Front End Flash	Error in flash memory on front end board.	Reset control. Reset control parameters to factory settings. Hardware failure, contact service.
Front End Error	Memory access error in front end processor.	Reset control. Reset control parameters to factory settings. Hardware failure, contact service.
DC link Ripple	Excessive ripple on DC bus. Input power has noise on the lines.	Reset control. If error still exists, use the diagnostic screens and check that the bus voltage is within $\pm 5VDC$ of rating (230VAC=325VDC bus, 460VAC=650VDC bus). Contact Baldor service.
Overcurrent #1	Over current was detected.	If occurred during ramping motor at start up, check load. Check boost setting, V/HZ profile. Increase accel time. Increase or decrease torque boost. Change V/HZ profile to a square law setting, or try 9 points. Motor may be shorted. Contact Baldor service.
Overcurrent #2	Over current was detected.	
Overcurrent #3	Over current was detected.	
Converter Error	Hardware detected by power module.	Reset fault. Reset power. Contact Baldor service.
Excess Resets/HR	Too many attempted auto restarts in 1 hour.	Clear fault log. Be sure no more than maximum number of restarts occur per hour as set by RESTART FAULT/HR parameter. This should only occur if you are doing auto restarts. Set RESTART AUTO/MAN to MANUAL if not needed.
Com Error logged	Communication failure between the front end and motor control microcontrollers.	This error occurs after a communication error has occurred and may stop the motor. Check the fault log for more errors, possibly Internal com. The green LED should blink consistently. An erratic blinking pattern might indicate noise in the communication hardware. Check input power and all wires connected to the smart motor.
Frame error	Internal buffer overrun error.	Reset control. Reset control parameters to factory settings. Hardware failure, contact service.
Command error	Command buffer overrun error.	Commands received from a remote serial terminal are spaced too closely. Commands must be spaced at least 75ms apart.
Parameter error	Parameter buffer overrun error.	If this occurred while being commanded by the remote terminal, check that the input reference is not corrupted by noise. Check if frequency reference in diagnostic menu is changing according to your input signal.
External Trip	Motor ventilation insufficient.	Clean motor air intake and exhaust. Verify motor's internal fan is coupled securely.
	Motor drawing excessive current.	Check motor for overloading. Verify proper SmartMotor rating.
	V/HZ profile incorrect.	Adjust volts/hertz. Adjust CTRL base frequency. Adjust max output voltage.
	No thermostat connected.	Connect thermostat. Verify connection of all external trip circuits used with thermostat. Disable thermostat input at control.
	External trip parameter incorrect.	Set external trip parameter to "OFF".

Section 6 Specifications & Product Data

Specifications:

Horsepower	1 to 10 HP @ 230VAC 1 to 10 HP @ 460VAC
Input Frequency	50/60 HZ \pm 5%
Service Factor	1.0
Duty	Continuous
Overload Capacity	Constant Torque Rating: 200% for 3 secs 150% for 60 secs Variable Torque Rating: 115% for 60 secs
Storage Temperature	-30 °C to +65 °C
Control Method	Sinewave Carrier Input, PWM Output
Frequency Accuracy	0.125 Hz @ 60Hz
Frequency Resolution	0.1 Hz Digital (0.05 % Analog)
Carrier Frequency	2.2kHz to 18kHz Adjustable
Transistor Type	Fast Switching Transistor
Transistor Rise Time	2500V/ μ sec. (dv/dt)
Torque Boost	Automatic adjustment to load (Standard) 0 to 15% of Input Voltage (Manual)
Volts/Hertz Pattern	Linear, Squared Reduced, Nine Point
Accel/Decel Time	0 to 3600 sec. for 2 Assignable Plus JOG
S-Curves	0 to 100%
Base Frequency	10 to 120Hz
Regenerative Braking Torque	20% minimum
JOG Frequency	0 to 120Hz
Skip Frequency	0 to 120Hz
Minimum Output Frequency	0 to 120Hz
Maximum Output Frequency	0 to maximum Frequency
Auto Restart	Manual or Automatic
Slip Compensation	0 to 6 Hz
Operating Modes	KEYPAD, #1, 2 Wire/7Speed, #2, 2 Wire/Trip, #3, 2 Wire/3 Speed, #4, 3 Wire/3 Speed, #5, 3 Wire/Trip, #6, 2 Wire/Electronic Potentiometer, #7, 3 Wire/Electronic Potentiometer PROF RUN-REM PROF RUN-LOC PID Mode PID:Stop-Mode

Operating Conditions:

Voltage Range:	230 VAC Models	180-264 VAC 3 ϕ 50/60 Hz or 280-340 VDC
	460 VAC Models	340-528 VAC 3 ϕ 50/60 Hz or 535-680 VDC
Input Frequency Variation		\pm 5%
Input Line Impedance		1% Minimum Required
Ambient Operating Temperature		0 to +40 °C Derate output 2% per °C over 40 °C to 55 °C Max
Enclosure		Motor - TEFC Control - IP54
Humidity		10 to 90% RH non-condensing
Altitude		Sea level to 3300 feet (1000 meters) Derate 2% per 1000 feet (303 meters) above 3300 feet

Optional Keypad Display:

Display	Backlit LCD alphanumeric 2 Lines x 16 characters
Keys	12 key Membrane with tactile response
Functions	Output status monitoring Digital speed control Parameter setting and display Fault log display Motor run and jog Local/Remote toggle
LED Indicators	Forward run command Reverse run command Stop command Jog active
Connector Type	RJ-12 Series (6 conductor phone jack)
Remote Mount	100 feet max from control

Analog Input:

Full Scale Range	0 - 5 VDC, 0 - 10 VDC, 0 - 20 mA, 4 - 20 mA
Resolution	8 bits
Input Impedance	20k Ω

Analog Output:

Full Scale Range	0-10 VDC, 0-5 VDC
Source Current	1 mA maximum
Resolution	8 bits
Conditions	Frequency, Freq Command, AC Current, AC Voltage, Bus Voltage, Zero Calibration, 100% Calibration and Temperature

Digital Inputs:

Opto-isolated Logic Inputs	5 Assignable
Rated Voltage	10 - 30 VDC (closed contacts standard)
Input Impedance	10 k Ω
Leakage Current	10 μ A maximum

Digital Output:

ON Current Sink	60 mA Max
ON Voltage Drop	2 VDC Max
Conditions	10 conditions Ready, Zero Speed, At Speed, At Set Speed, Overload, Underload, Keypad Control, Fault, Drive ON, Reverse and Process Error

Diagnostic Indications:

CONVERTER ERROR	FAULT CODE XX
CONVERTER EEPROM	EXCESS HSD/1 MIN
H/W SHUTDOWN	FRONT END EEPROM
LEAKAGE CURRENT	FRONT END FLASH
1 MIN TIMEOUT	FRONT END ERROR
3 SEC TIMEOUT	DC LINK RIPPLE
DC LINK HIGH	OVERCURRENT #1
DC LINK dv/dt HI	EXCESS RESETS/HR
DC LINK LOW	COM ERROR LOGGED
HIGH TEMPERATURE	OVERCURRENT #2
EXTERNAL TRIP	OVERCURRENT #3
REGEN RES POWER	FRAME ERROR
DIGITAL OUT CUR	COMMAND ERROR
INTERNAL COM	PARAMETER ERROR

Note: All specifications are subject to change without notice.

Ratings – SmartMotor Constant Torque – NEMA 1 Control Enclosure

Catalog Number	HP @ Base Speed	Base Speed @ 60Hz	NEMA Frame	Constant Torque Speed Range		Max Output Speed	Input Current (Amps)	Rated PWM Freq. (kHz)	Baldor Type	Approx. Shipping Weight
				Min RPM	Max RPM					
230 Volt Input										
CSM3546 - 2	1	1750	56TC	180	1800	3500	3.1	18.0	DV3524M	39
CSM3546T - 2	1	1750	143TC	180	1800	3500	3.1	18.0	DV3524M	53
CSM3558T - 2	2	1750	145TC	180	1800	3500	5.7	18.0	DV3540M	65
CSM3611T - 2	3	1760	182TC	180	1800	3520	10.5	18.0	DV3628M	87
CSM3615T - 2	5	1760	185TC	180	1800	3520	15.9	9.0	DV3646M	114
CSM3710T - 2	7.5	1725	213TC	180	1800	3450	22.8	9.0	DV3734M	148
CSM3714T - 2	10	1725	215TC	180	1800	3450	29.3	9.0	DV3746M	175
460 Volt Input										
CSM3546 - 4	1	1750	56C	180	1800	3500	1.6	18.0	DV3524M	39
CSM3546T - 4	1	1750	143TC	180	1800	3500	1.6	18.0	DV3524M	42
CSM3558T - 4	2	1750	145TC	180	1800	3500	2.9	18.0	DV3540M	67
CSM3611T - 4	3	1760	182TC	180	1800	3520	5.4	18.0	DV3628M	91
CSM3615T - 4	5	1760	185TC	180	1800	3520	7.8	9.0	DV3646M	98
CSM3710T - 4	7.5	1725	213TC	180	1800	3450	11.4	9.0	DV3734M	148
CSM3714T - 4	10	1725	215TC	180	1800	3450	14.7	9.0	DV3746M	175

Ratings – SmartMotor Constant Torque – NEMA 4 Control Enclosure

Catalog Number	HP @ Base Speed	Base Speed @ 60Hz	NEMA Frame	Constant Torque Speed Range		Max Output Speed	Input Current (Amps)	Rated PWM Freq. (kHz)	Baldor Type	Approx. Shipping Weight
				Min RPM	Max RPM					
230 Volt Input										
CWDSM3546 - 2	1	1750	56C	180	1800	3500	3.1	18.0	DV3524M	59
CWDSM3546T - 2	1	1750	143TC	180	1800	3500	3.1	18.0	DV3524M	60
CWDSM3558T - 2	2	1750	145TC	180	1800	3500	5.7	18.0	DV3540M	66
CWDSM3611T - 2	3	1760	182TC	180	1800	3520	10.5	18.0	DV3628M	97
CWDSM3615T - 2	5	1760	185TC	180	1800	3520	15.9	9.0	DV3646M	92
CWDSM3710T - 2	7.5	1725	213TC	180	1800	3450	22.8	9.0	DV3734M	162
CWDSM3714T - 2	10	1725	215TC	180	1800	3450	29.3	9.0	DV3746M	186
460 Volt Input										
CWDSM3546 - 4	1	1750	56C	180	1800	3500	1.6	18.0	DV3524M	39
CWDSM3546T - 4	1	1750	143TC	180	1800	3500	1.6	18.0	DV3524M	60
CWDSM3558T - 4	2	1750	145TC	180	1800	3500	2.9	18.0	DV3540M	66
CWDSM3611T - 4	3	1760	182TC	180	1800	3520	5.4	18.0	DV3628M	98
CWDSM3615T - 4	5	1760	185TC	180	1800	3520	7.8	9.0	DV3646M	92
CWDSM3710T - 4	7.5	1725	213TC	180	1800	3450	11.4	9.0	DV3734M	162
CWDSM3714T - 4	10	1725	215TC	180	1800	3450	14.7	9.0	DV3746M	187

Ratings – SmartMotor Variable Torque Pump Motors – NEMA 1 Control Enclosure

Catalog Number	HP @ Base Speed	Base Speed @ 60Hz	NEMA Frame	Variable Torque Speed Range		Max Output Speed	Input Current (Amps)	Rated PWM Freq. (kHz)	Baldor Type	Approx. Shipping Weight
				Min RPM	Max RPM					
230 Volt Input										
JMSM3545T-2	1	3450	143JM	180	3450	3600	3.4	18.0	DV3516M	60
JMSM3555T-2	2	3450	145JM	180	3450	3600	6.1	18.0	DV3532M	60
JMSM3610T-2	3	3450	182JM	300	3450	6000	10.5	18.0	DV3628M	62
JMSM3613T-2	5	3450	185JM	300	3450	6000	15.9	9.0	DV3634M	67
JMSM3709T-2	7.5	3450	213JM	400	3450	6000	22.8	9.0	DV3733M	158
JMSM3711T-2	10	3450	215JM	400	3450	6000	29.3	9.0	DV3738M	162
460 Volt Input										
JMSM3545T-4	1	3450	143JM	180	3450	3600	1.7	18.0	DV3516M	35
JMSM3555T-4	2	3450	145JM	180	3450	3600	3.1	18.0	DV3532M	51
JMSM3610T-4	3	3450	182JM	300	3450	6000	5.4	18.0	DV3628M	54
JMSM3613T-4	5	3450	185JM	300	3450	6000	7.8	9.0	DV3634M	67
JMSM3709T-4	7.5	3450	213JM	400	3450	6000	11.4	9.0	DV3733M	158
JMSM3711T-4	10	3450	215JM	400	3450	6000	14.7	9.0	DV3738M	162

Terminal Tightening Torque Specifications – NEMA 1 Control Enclosure

Catalog Number	HP @ Base Speed	Base Speed @ 60Hz	NEMA Frame	Power Terminal TB1		Casting Ground	
				Lb-In	Nm	Lb-In	Nm
230 Volt Input							
CSM3546- 2	1	1750	56C	11-13	1.2-1.5	50-60	5.6-6.8
CSM3546T- 2	1	1750	143TC	11-13	1.2-1.5	50-60	5.6-6.8
CSM3558T - 2	2	1750	145TC	11-13	1.2-1.5	50-60	5.6-6.8
CSM3611T - 2	3	1760	182TC	11-13	1.2-1.5	50-60	5.6-6.8
CSM3615T - 2	5	1760	185TC	11-13	1.2-1.5	50-60	5.6-6.8
CSM3710T - 2	7.5	1725	213TC	11-13	1.2-1.5	50-60	5.6-6.8
CSM3714T - 2	10	1725	215TC	11-13	1.2-1.5	50-60	5.6-6.8
460 Volt Input							
CSM3546- 4	1	1750	56C	11-13	1.2-1.5	50-60	5.6-6.8
CSM3546T- 4	1	1750	143TC	11-13	1.2-1.5	50-60	5.6-6.8
CSM3558T - 4	2	1750	145TC	11-13	1.2-1.5	50-60	5.6-6.8
CSM3611T - 4	3	1760	182TC	11-13	1.2-1.5	50-60	5.6-6.8
CSM3615T - 4	5	1760	185TC	11-13	1.2-1.5	50-60	5.6-6.8
CSM3710T - 4	7.5	1725	213TC	11-13	1.2-1.5	50-60	5.6-6.8
CSM3714T - 4	10	1725	215TC	11-13	1.2-1.5	50-60	5.6-6.8

Terminal Tightening Torque Specifications – NEMA 4 Control Enclosure

Catalog Number	HP @ Base Speed	Base Speed @ 60Hz	NEMA Frame	Power Terminal TB1		Casting Ground	
				Lb-In	Nm	Lb-In	Nm
230 Volt Input							
CWDSM3546- 2	1	1750	56C	11-13	1.2-1.5	50-60	5.6-6.8
CWDSM3546T- 2	1	1750	143TC	11-13	1.2-1.5	50-60	5.6-6.8
CWDSM3558T - 2	2	1750	145TC	11-13	1.2-1.5	50-60	5.6-6.8
CWDSM3611T - 2	3	1760	182TC	11-13	1.2-1.5	50-60	5.6-6.8
CWDSM3615T - 2	5	1760	185TC	11-13	1.2-1.5	50-60	5.6-6.8
CWDSM3710T - 2	7.5	1725	213TC	11-13	1.2-1.5	50-60	5.6-6.8
CWDSM3714T - 2	10	1725	215TC	11-13	1.2-1.5	50-60	5.6-6.8
460 Volt Input							
CWDSM3546- 4	1	1750	56C	11-13	1.2-1.5	50-60	5.6-6.8
CWDSM3546T- 4	1	1750	143TC	11-13	1.2-1.5	50-60	5.6-6.8
CWDSM3558T - 4	2	1750	145TC	11-13	1.2-1.5	50-60	5.6-6.8
CWDSM3611T - 4	3	1760	182TC	11-13	1.2-1.5	50-60	5.6-6.8
CWDSM3615T - 4	5	1760	185TC	11-13	1.2-1.5	50-60	5.6-6.8
CWDSM3710T - 4	7.5	1725	213TC	11-13	1.2-1.5	50-60	5.6-6.8
CWDSM3714T - 4	10	1725	215TC	11-13	1.2-1.5	50-60	5.6-6.8

Terminal Tightening Torque Specifications Pump Motors – NEMA 1 Control Enclosure

Catalog Number	HP @ Base Speed	Base Speed @ 60Hz	NEMA Frame	Power Terminal TB1		Casting Ground	
				Lb-In	Nm	Lb-In	Nm
230 Volt Input				230 Volt Input			
JMSM3545T-2	1	3450	143TC	11-13	1.2-1.5	50-60	5.6-6.8
JMSM3555T-2	2	3450	145TC	11-13	1.2-1.5	50-60	5.6-6.8
JMSM3610T-2	3	3450	182TC	11-13	1.2-1.5	50-60	5.6-6.8
JMSM3613T-2	5	3450	185TC	11-13	1.2-1.5	50-60	5.6-6.8
JMSM3709T-2	7.5	3450	213TC	11-13	1.2-1.5	50-60	5.6-6.8
JMSM3711T-2	10	3450	215TC	11-13	1.2-1.5	50-60	5.6-6.8
460 Volt Input				460 Volt Input			
JMSM3545T-4	1	3450	143TC	11-13	1.2-1.5	50-60	5.6-6.8
JMSM3555T-4	2	3450	145TC	11-13	1.2-1.5	50-60	5.6-6.8
JMSM3610T-4	3	3450	182TC	11-13	1.2-1.5	50-60	5.6-6.8
JMSM3613T-4	5	3450	185TC	11-13	1.2-1.5	50-60	5.6-6.8
JMSM3709T-4	7.5	3450	213TC	11-13	1.2-1.5	50-60	5.6-6.8
JMSM3711T-4	10	3450	215TC	11-13	1.2-1.5	50-60	5.6-6.8

SmartMotor™ Dimensions

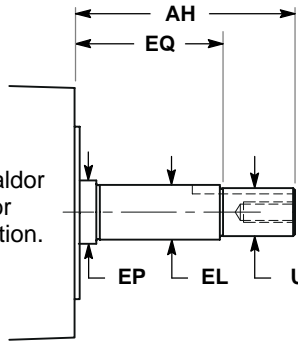
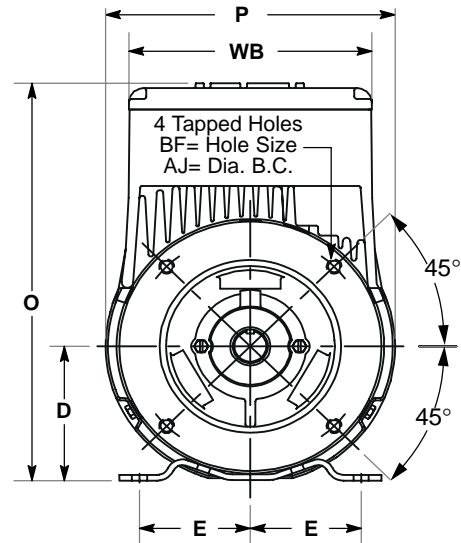
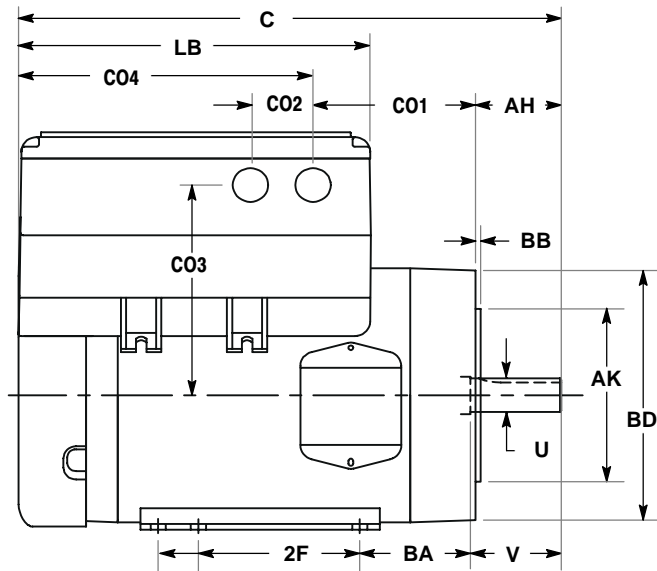

* Call your local Baldor District Office for dimension information.

"JM" Model	EQ	EL	EP	AH	U
143	2.890	1.00	1.156	4.281	0.8742
145	2.890	1.00	1.156	4.281	0.8742
182	2.890	1.00	1.125	4.281	0.8742
184	2.890	1.00	1.125	4.281	0.8742
213	3.140	1.00	1.125	4.50	0.8742
215	3.140	1.00	1.125	4.50	0.8742

.38-16 UNC (0.88 Deep)

Motor Shaft for "JM" Series

Model	Dimension																				
	2F	C	D	E	O	P	U	V	AH	AJ	AK	BA	BB	BD	BF	CO1	CO2	CO3	CO4	LB	WB
56C	3.00	13.40	3.5	2.44	10.36	7.18	.6250	1.93	2.06	5.88	4.5	2.75	0.13	6.51	.38-16	4.03	1.38	5.48	7.307	8.73	6.03
143TC	4.00	13.46	3.5	2.75	10.35	7.20	.8750	2.26	2.13	5.88	4.5	2.75	0.13	6.51	.38-16	4.03	1.38	5.48	7.307	8.71	6.03
143JM	4.00	16.44	3.5	2.75	10.35	7.18	.8745		4.281	5.88	4.5	2.88	0.13	6.50	.38-16	4.85	1.38	5.48	7.307	8.71	6.02
145TC	4.00	15.71	3.5	2.75	10.35	7.20	.8750	2.26	2.13	5.88	4.5	2.75	0.13	6.51	.38-16	4.03	1.38	5.48	7.307	8.71	6.03
145JM	4.00	17.32	3.5	2.75	10.35	7.18	.8745		4.281	5.88	4.5	2.88	0.13	6.50	.38-16	5.73	1.38	5.48	7.307	8.71	6.02
182TC	4.50	16.55	4.5	3.75	11.92	8.86	1.125	2.75	2.87	7.25	8.5	3.5	0.25	8.86	.50-13	3.96	1.38	5.58	9.72	11.26	7.12
182JM	4.50	18.18	4.5	3.75	11.81	8.49	.8745		4.281	5.88	4.5	3.51	0.13	6.61	.38-16	4.18	1.38	5.58	9.72	11.20	7.12
184TC	4.50	18.05	4.5	3.75	11.92	8.86	1.125	2.75	2.87	7.25	8.5	3.5	0.25	8.86	.50-13	5.46	1.38	5.58	9.72	11.26	7.12
184JM	4.50	18.18	4.5	3.75	11.81	8.49	.8745		4.281	5.88	4.5	3.51	0.13	6.61	.38-16	4.18	1.38	5.58	9.72	11.20	7.12
213TC	5.50	18.69	5.25	4.25	13.69	10.62	1.375	3.37	3.37	7.25	8.5	4.25	0.25	9.04	.50-13	4.79	1.91	7.11	10.58	11.75	8.27
213JM	5.50	19.86	5.25	4.25	13.93	10.62	.8745		4.50	7.25	8.5	4.50	0.25	9.06	.50-13	4.78	1.91	7.11	10.58	11.92	8.27
215TC	5.50	20.52	5.25	4.25	13.69	10.62	1.375	3.37	3.37	7.25	8.5	4.25	0.25	9.04	.50-13	4.74	1.91	7.11	10.58	11.75	8.27
215JM	5.50	21.73	5.25	4.25	13.93	10.62	.8745		4.50	7.25	8.5	4.50	0.25	9.06	.50-13	6.65	1.91	7.11	10.58	11.92	8.27

Appendix A

Dynamic Braking (DB) Hardware

Whenever a motor is abruptly stopped or forced to slow down quicker than if allowed to coast to a stop, the motor becomes a generator. This energy appears on the DC Bus and must be dissipated using dynamic braking hardware. Table A-1 provides a matrix of DB turn ON and turn OFF voltages.

Table A-1

Parameter Description	Rating	
Control Input Voltage (Nominal)	230VAC	460VAC
Overvoltage Fault (Voltage exceeded)	400VDC	800VDC
DB ON Voltage	368VDC	748VDC

Braking torque and time should not exceed the available drive braking torque and time rating. The drive braking torque is limited to the available peak current and peak current time rating of the control. If the peak current or peak current time limit is exceeded during braking, the control may trip on an over voltage or a regen power fault. Selecting an oversized control or a line regenerative control should be considered in these cases.

Selection Procedure

1. Calculate the watts to be dissipated using the following formulas for the appropriate load type.
2. Identify the SmartMotor model number and determine which braking hardware is required.
3. Select appropriate braking hardware. If required braking watts exceeds the available braking watts, contact Baldor.

Hoisting Load Calculations

1. Calculate braking duty cycle:
$$\text{Duty Cycle} = \frac{\text{Lowering Time}}{\text{Total Cycle Time}}$$
2. Calculate braking watts to be dissipated in dynamic braking resistors:
$$\text{Watts} = \frac{\text{duty cycle} \times \text{lbs} \times \text{FPM} \times \text{efficiency}}{44}$$

where: lbs = weight of load
FPM = Feet Per Minute
efficiency = mechanical efficiency
i.e., 95% = 0.95

Dynamic Braking (DB) Hardware Continued

General Machinery Load Calculations:

1. Calculate braking duty cycle:

$$\text{Duty Cycle} = \frac{\text{Braking Time}}{\text{Total Cycle Time}}$$

2. Calculate deceleration torque:

$$T_{\text{Decel}} = \frac{\text{RPM change} \times Wk^2}{308 \times \text{time}} - \text{Friction}_{(\text{Lb.Ft.})}$$

where: T_{Decel} = Deceleration torque in Lb.-ft.
 Wk^2 = Inertia in Lb.ft.²
time = In seconds

3. Calculate watts to be dissipated in dynamic braking resistor:

$$\text{Watts} = T_{\text{Decel}} \times (S_{\text{max}} - S_{\text{min}}) \times \text{Duty Cycle} \times (0.0712)$$

where: S_{max} = Speed at braking start
 S_{min} = Speed after braking

4. Multiply watts calculated in step 3 by 1.25 to allow for unanticipated loads (safety factor).

Each SmartMotor is equipped with a factory installed dynamic brake transistor and brake resistor. These can provide 100% braking torque for 6 seconds of a 20% braking duty cycle.

Table A-2

Rated HP	Watts
1-2	250
3-5	300
7.5-10	500

Appendix B

Parameter Values

Table B-1 Parameter Block Values Level 1

Level 1 Blocks				
Block Title	Parameter	Adjustable Range	Factory Setting	User Setting
PRESET SPEEDS	PRESET SPEED #1	0-Max Output Freq	15.0 HZ	
	PRESET SPEED #2	0-Max Output Freq	30.0 HZ	
	PRESET SPEED #3	0-Max Output Freq	60.0 HZ	
	PRESET SPEED #4	0-Max Output Freq	20.0 HZ	
	PRESET SPEED #5	0-Max Output Freq	40.0 HZ	
	PRESET SPEED #6	0-Max Output Freq	45.0 HZ	
	PRESET SPEED #7	0-Max Output Freq	50.0 HZ	
ACCEL/DECEL RATE	ACCEL TIME #1	0.1 to 3600.0 SECONDS	3.0 S	
	DECEL TIME #1	0.1 to 3600.0 SECONDS	3.0 S	
	S-CURVE #1	OFF, 20, 40, 60, 80, 100%	OFF	
	ACCEL TIME #2	0.1 to 3600.0 SECONDS	20.0 S	
	DECEL TIME #2	0.1 to 3600.0 SECONDS	20.0 S	
	S-CURVE #2	OFF, 20, 40, 60, 80, 100%	OFF	
JOG SETTINGS	JOG SPEED	0-Max Output Freq	5.0 HZ	
	JOG ACCEL TIME	0.1 to 3600.0 SECONDS	20.0 S	
	JOG DECEL TIME	0.1 to 3600.0 SECONDS	20.0 S	
	JOG S-CURVE	OFF, 20, 40, 60, 80, 100%	OFF	
KEYPAD SETUP	KEYPAD STOP KEY	REMOTE ON (Stop key active during remote operation). REMOTE OFF (Stop key inactive during remote operation).	REMOTE ON	
	KEYPAD STOP MODE	COAST, REGEN	REGEN	
	KEYPAD RUN FWD	OFF, ON	ON	
	KEYPAD RUN REV	OFF, ON	ON	
	KEYPAD JOG FWD	OFF, ON	ON	
	KEYPAD JOG REV	OFF, ON	ON	
INPUT	OPERATING MODE	KEYPAD; #1 2WIRE/7SPD; #2 2WIRE/TRIP; #3 2WIRE/3SPD #4 3WIRE/3SPD; #5 3WIRE/TRIP; #6 2WIRE/EPOT; #7 3WIRE/EPOT; PROF RUN-REM; PROF RUN-LOC; PID MODE; PID:STOP-MODE; SERIAL MODE; SERIAL-PID	#1 2Wire/7SPD	
	(Serial modes are not used)			
	ANA CMD SELECT	POTENTIOMETER 0-10 VOLTS, 0-5 VOLTS, 4 TO 20 mA, 0 TO 20 mA	POTENTIOMETER	
	ANA CMD INVERSE	OFF, ON	OFF	
	ANA CMD OFFSET	-20.0 TO +20.0%	0.0%	
	ANA CMD GAIN	80.0 - 120.0%	100%	
ANA CMD FILTER	0 - 6	3		

Table B-1 Parameter Block Values Level 1 Continued

Level 1 Blocks - Continued				
Block Title	Parameter	Adjustable Range	Factory Setting	User Setting
OUTPUT	OPTO OUTPUT #1	READY, ZERO SPEED, AT SPEED, AT SET SPEED, OVERLOAD, UNDERLOAD, KEYPAD CONTROL, FAULT, DRIVE ON, REVERSE, PROCESS ERROR	READY	
	ZERO SPD SET PT	0-Max Output Freq	6.0 HZ	
	AT SPEED BAND	0-20.0 HZ	2.0 HZ	
	SET SPEED POINT	0-Max Output Freq	60.0 HZ	
	OVERLOAD SET PT	0.2 to Peak Rated Current	Peak Rated Current	
	UNDERLOAD SET PT	0.2 to Peak Rated Current	0.2A	
	ANA VOLT RANGE	0-10, 0-5 VOLTS	0-10 VOLTS	
	ANALOG OUT #1	FREQUENCY, FREQ COMMAND, AC CURRENT, AC VOLTAGE, BUS VOLTAGE, ZERO CAL, 100% CAL, TEMPERATURE	FREQUENCY	
	ANALOG SCALE #1	10 - 160%	100%	
V/HZ AND BOOST	CTRL BASE FREQ	10 - 120 HZ	60 HZ	
	TORQUE BOOST	0 - 15%	Factory Set	
	DYNAMIC BOOST	0.0 - 100.0%	0%	
	SLIP COMP ADJ	0.00 - 6.00 HZ	0.0 HZ	
	V/HZ PROFILE	LINEAR, 33% SQUARE LAW, 67% SQUARE LAW, 100% SQUARE LAW 9 POINTS	LINEAR	
		MAX OUTPUT VOLTS	0 - 100%	100%
LEVEL 2 BLOCK	ENTERS LEVEL 2 MENU - See Table B-2.			
PRESS ENTER FOR PROGRAMMING EXIT	Exit programming mode and return to display mode.			

Table B-2 Parameter Block Values Level 2

Level 2 Blocks				
Block Title	Parameter	Adjustable Range	Factory Setting	User Setting
OUTPUT LIMITS	MIN OUTPUT FREQ	0-60.0 HZ	0.0 HZ	
	MAX OUTPUT FREQ	0 -120.0 HZ	60.0 HZ	
	PK CURRENT LIMIT	0.1 TO PEAK RATED CURRENT	PK RATING	
	PWM FREQUENCY	2.2, 3.0, 4.5, 6.0, 9.0, 18.0 KHz	2.2kHz	
CUSTOM UNITS	DECIMAL PLACES	0-5	5	
	VALUE AT SPEED	0-65535/1-65535RPM	0/ 1RPM	
	UNITS OF MEASURE	See Table 4-2 description.	****	
PROTECTION	EXTERNAL TRIP	OFF, ON	OFF	
	PWM vs TEMP	OFF, ON	ON	
	FOLDBACK PROTECT	OFF, ON	ON	
MISCELLANEOUS	RESTART AUTO/MAN	AUTOMATIC, MANUAL	MANUAL	
	RESTART FAULT/HR	0-10	10	
	RESTART DELAY	0-120 SECONDS	30 S	
	STABILITY COMP	0 - 100%	Factory Set	
	FACTORY SETTINGS	YES, NO	NO	
SECURITY CONTROL	SECURITY STATE	OFF, LOCAL SECURITY, SERIAL SECURITY, TOTAL SECURITY	OFF	
	ACCESS TIMEOUT	0-600 S	0 S	
	ACCESS CODE	0-9999	9999	
MOTOR DATA	MOTOR VOLTAGE	120 - 510 VOLTS	Factory Set	
	MOTOR RATED AMPS	0-Rated Amps	Factory Set	
	MOTOR RATED SPD	0-24000 RPM	Factory Set	
	MOTOR RATED FREQ	10 - 255 HZ	Factory Set	
	MOTOR MAG AMPS	0-Rated Amps	Factory Set	
BRAKE ADJUST	RESISTOR OHMS	0-255 OHMS	Factory Set	
	RESISTOR WATTS	0-12750 WATTS	Factory Set	
	DC BRAKE VOLTAGE	1 to 15.0%	0.0%	
	DC BRAKE FREQ	1 - 120 HZ	10 HZ	
	BRAKE ON STOP	OFF, ON	OFF	
	BRAKE ON REVERSE	OFF, ON	OFF	
	STOP BRAKE TIME	0 - 60 S	0 S	
	BRAKE ON START	OFF, ON	OFF	
START BRAKE TIME	0 - 60 S	0 S		

Table B-2 Parameter Block Values Level 2 Continued

Level 2 Blocks - Continued				
Block Title	Parameter	Adjustable Range	Factory Setting	User Setting
PROCESS CONTROL	PROCESS FEEDBACK	POTENTIOMETER, 0–10 VOLTS, 0–5 VOLTS, 4 TO 20mA, 0 TO 20 mA, NONE	POTENTIOMETER	
	PROCESS INVERSE	OFF, ON	OFF	
	SETPOINT SOURCE	SET POINT COMMAND, NONE	SET POINT COMMAND	
	SETPOINT COMMAND	10–100%	0%	
	SETPOINT MAX STEP	0–100%	10%	
	AT SETPOINT BAND	0–100%	10%	
	PROCESS PROP GAIN	0–255	5	
	PROCESS INT GAIN	0.10–9.99	1.50Hz	
	PROCESS DIFF GAIN	0.1–6553.5	0.1	
	MIN FREQ HYST	0–120Hz	0Hz	
COMMUNICATION	PROTOCOL			(Factory use only).
	BAUD RATE			(Factory use only).
	DRIVE ADDRESS			(Factory use only).
SKIP FREQUENCY	SKIP FREQ #1	0-120 HZ	0 HZ	
	SKIP BAND #1	0-50 HZ	0 HZ	
	SKIP FREQ #2	0-120 HZ	0 HZ	
	SKIP BAND #2	0-50 HZ	0 HZ	
	SKIP FREQ #3	0-120 HZ	0 HZ	
	SKIP BAND #3	0-50 HZ	0 HZ	
SYNCHRO STARTS	SYNCHRO–STARTS	RESTARTS ONLY, ALL STARTS, OFF	OFF	
	SYNC START FREQ	MAX FREQUENCY, SET FREQ	MAX FREQUENCY	
	SYNC SCAN V/F	5 - 100%	15%	
	SYNC SETUP TIME	0.2 - 2.0 S	1.0 S	
	SYNC SCAN TIME	1.0 - 10.0 S	10.0 S	
	SYNC V/F RECOVER	0.2 - 2.0 S	1.0 S	
	SYNC DIRECTION	SYNC FORWARD, SYNC REVERSE, SYNC FWD & REV	SYNC FWD & REV	

Table B-2 Parameter Block Values Level 2 Continued

Level 2 Blocks - Continued				
Block Title	Parameter	Adjustable Range	Factory Setting	User Setting
PROFILE RUN	NUMBER OF CYCLES	0 - 255	0	
	RP RESTART MODE	PROF RE-START, PROF CONTINUE	PROF RE-START	
	SPD #1 CURVE/DIR	ACC/DEC#1,FWD; ACC/DEC#1,REV ACC/DEC#2,FWD; ACC/DEC#2,REV	ACC/ DEC#1,FWD	
	PROFILE TIME #1	0 - 65535 S	0 S	
	SPD #2 CURVE/DIR	ACC/DEC#1,FWD; ACC/DEC#1,REV ACC/DEC#2,FWD; ACC/DEC#2,REV	ACC/ DEC#1,FWD	
	PROFILE TIME #2	0 - 65535 S	0 S	
	SPD #3 CURVE/DIR	ACC/DEC#1,FWD; ACC/DEC#1,REV ACC/DEC#2,FWD; ACC/DEC#2,REV	ACC/ DEC#1,FWD	
	PROFILE TIME #3	0 - 65535 S	0 S	
	SPD #4 CURVE/DIR	ACC/DEC#1,FWD; ACC/DEC#1,REV ACC/DEC#2,FWD; ACC/DEC#2,REV	ACC/ DEC#1,FWD	
	PROFILE TIME #4	0 - 65535 S	0 S	
	SPD #5 CURVE/DIR	ACC/DEC#1,FWD; ACC/DEC#1,REV ACC/DEC#2,FWD; ACC/DEC#2,REV	ACC/ DEC#1,FWD	
	PROFILE TIME #5	0 - 65535 S	0 S	
	SPD #6 CURVE/DIR	ACC/DEC#1,FWD; ACC/DEC#1,REV ACC/DEC#2,FWD; ACC/DEC#2,REV	ACC/ DEC#1,FWD	
	PROFILE TIME #6	0 - 65535 S	0 S	
	SPD #7 CURVE/DIR	ACC/DEC#1,FWD; ACC/DEC#1,REV ACC/DEC#2,FWD; ACC/DEC#2,REV	ACC/ DEC#1,FWD	
PROFILE TIME #7	0 - 65535 S	0 S		
LEVEL 1 BLOCK	Enters Level 1 Menu - See Table B-1.			
PRESS ENTER FOR PROGRAMMING EXIT	Exit programming mode and return to display mode.			

Appendix C

Remote Keypad Mounting Template

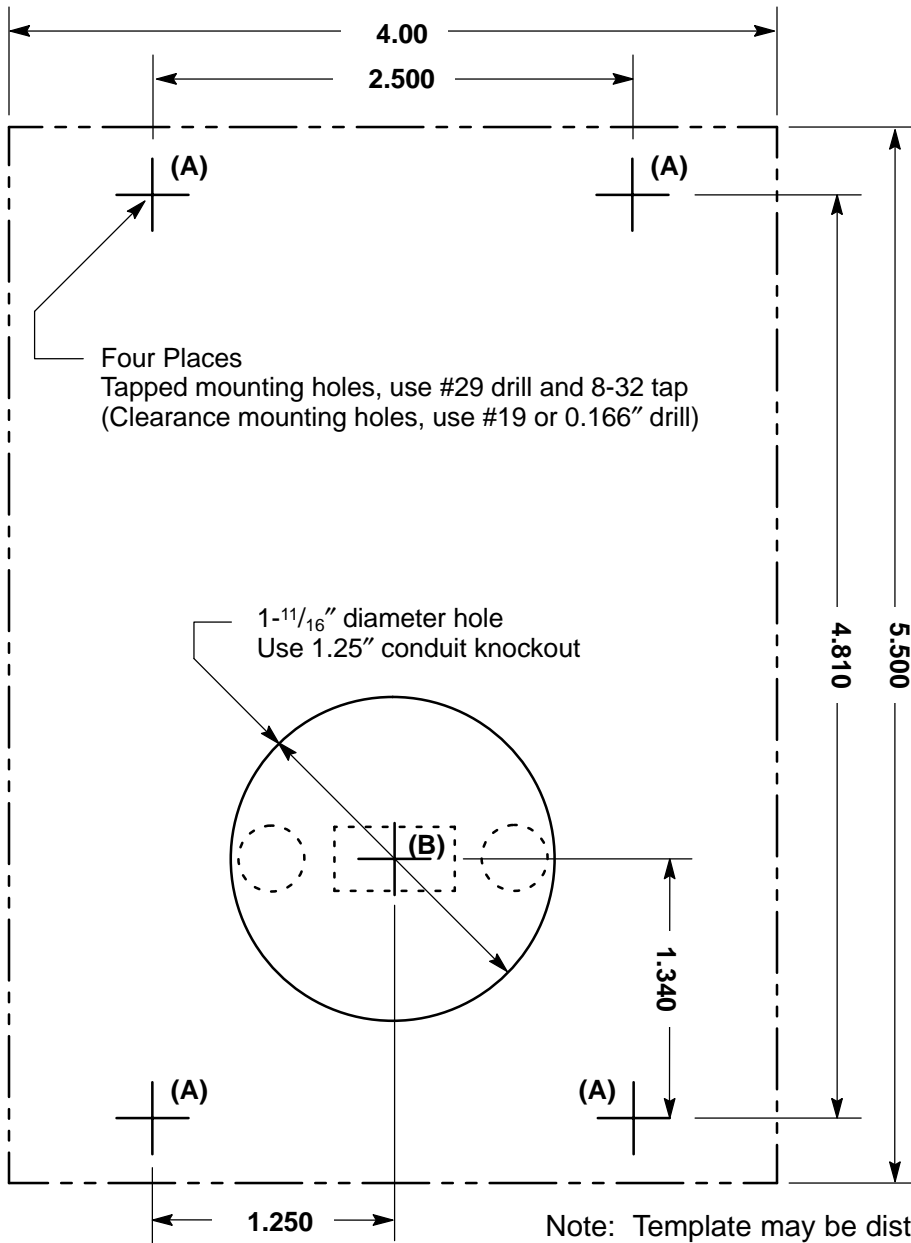

BALDOR[®] **MOTORS AND DRIVES**

BALDOR ELECTRIC COMPANY
P.O. Box 2400
Ft. Smith, AR 72902-2400
(479) 646-4711
Fax (479) 648-5792

CH TEL: +41 52 647 4700 FAX: +41 52 659 2394	D TEL: +49 89 90 50 80 FAX: +49 89 90 50 8491	UK TEL: +44 1454 850000 FAX: +44 1454 859001	F TEL: +33 145 10 7902 FAX: +33 145 09 0864
I TEL: +39 11 562 4440 FAX: +39 11 562 5660	AU TEL: +61 29674 5455 FAX: +61 29674 2495	CC TEL: +65 744 2572 FAX: +65 747 1708	MX TEL: +52 47 61 2030 FAX: +52 47 61 2010