



# Series 25M Multi-Axis Vector Control

(Includes 3 Phase - PO and  
1 Phase - TR Versions)

Installation & Operating Manual

3/01



MN725

57 Galaxy Blvd., Units 1 & 2, Toronto, ON M9W 5P1  
TEL: (416) 231-6767  
[www.drivecentre.ca](http://www.drivecentre.ca)

# Table of Contents

---

<b>Section 1</b>	
<b>Quick Start Guide</b> .....	1-1
Overview .....	1-1
Quick Start Checklist .....	1-1
Quick Start Procedure .....	1-2
<b>Section 2</b>	
<b>General Information</b> .....	2-1
Introduction .....	2-1
Limited Warranty .....	2-2
Safety Notice .....	2-3
<b>Section 3</b>	
<b>Installation</b> .....	3-1
Receiving & Inspection .....	3-1
Location Considerations .....	3-1
Mechanical Installation .....	3-2
PSM Procedure .....	3-2
Control Procedure .....	3-2
Through Wall Mounting .....	3-2
Keypad Installation .....	3-2
Remote Keypad Installation .....	3-3
Electrical Installation .....	3-4
System Grounding .....	3-4
Line Impedance .....	3-5
Line Reactors .....	3-5
Load Reactors .....	3-5
Power Disconnect .....	3-6
Protection Devices .....	3-6
Power Connections .....	3-7
Optional PSM-PR I/O Connections .....	3-11
Motor Connections .....	3-12
M-Contactor .....	3-12
Dynamic Brake Resistor .....	3-12
Encoder Installation .....	3-12
Home (Orient) Switch Input .....	3-13
Buffered Encoder Output .....	3-13
Analog Inputs and Outputs .....	3-14
Analog Inputs .....	3-14
Analog Outputs .....	3-16
External Trip Input .....	3-16
Opto-Isolated Outputs .....	3-17
Control Circuit Connections .....	3-18
Opto Isolated Inputs .....	3-18

---

25M Operating Mode Configurations .....	3-19
Opto Input Switch Power Connections .....	3-19
Serial Operating Mode .....	3-19
Keypad Operating Mode .....	3-20
Standard Run 3 Wire Mode .....	3-21
15 Speed 2-Wire Mode .....	3-22
3 SPD ANA 2 Wire Control Mode .....	3-23
3 SPD ANA 3 Wire Control Mode .....	3-24
Bipolar Speed or Torque Control Mode with Multiple Parameter Sets .....	3-25
Multiple Parameter Sets .....	3-26
Process Mode Connections .....	3-27
EPOT– 2 Wire Control Mode .....	3-28
EPOT– 3 Wire Control Mode .....	3-29
Pre-Operation Checklist .....	3-29
Power-Up Procedure .....	3-30
<b>Section 4</b>	
<b>Programming and Operation .....</b>	<b>4-1</b>
Overview .....	4-1
Display Mode .....	4-2
Adjusting Display Contrast .....	4-2
Display Screens & Diagnostic Information Access .....	4-3
Fault Log Access .....	4-4
Program Mode .....	4-5
Parameter Blocks Access for Programming .....	4-5
Changing Parameter Values when Security Code Not Used .....	4-6
Reset Parameters to Factory Settings .....	4-7
Initialize New Software .....	4-8
Operation Examples .....	4-9
Operating the Control from the Keypad .....	4-9
Accessing the Keypad JOG Command .....	4-9
Speed Adjustment using the Keypad .....	4-10
Speed Adjustment Using Arrow Keys .....	4-10
Security System Changes .....	4-11
Changing Parameter Values with a Security Code in Use .....	4-12
Security System Access Timeout Parameter Change .....	4-13
Parameter Adjustments .....	4-14

---

<b>Section 5</b>	
<b>Troubleshooting</b>	5-1
Overview	5-1
PSM-PR Troubleshooting Procedure	5-1
25M-PO Ready LED	5-1
25M-TR Indicators	5-1
Control Module Troubleshooting Procedure	5-2
No Keypad Display - Display Contrast Adjustment	5-2
How to Access the Fault Log	5-4
How to Clear the Fault Log	5-4
How to Access Diagnostic Information	5-5
Electrical Noise Considerations	5-11
Special Drive Situations	5-12
Control Enclosures	5-12
Special Motor Considerations	5-12
Analog Signal Wires	5-12
<b>Section 6</b>	
<b>Manually Tuning the Series 25M Control</b>	6-1
Manually Tuning the Control	6-1
Motor Mag Amps Parameter	6-1
Slip Frequency Parameter	6-1
Current Prop Gain Parameter	6-1
Current Int Gain Parameter	6-2
Speed Prop Gain Parameter	6-2
Speed Int Gain Parameter	6-2
PI Controller	6-3

---

<b>Section 7</b>	
<b>Specifications and Product Data</b> .....	7-1
Identification .....	7-1
25M-TR Control Specifications: .....	7-2
25M-PO Control Specifications and Ratings: .....	7-3
PSM-PR Power Supply Specifications: .....	7-4
Keypad Display .....	7-5
Differential Analog Input: .....	7-5
Analog Outputs .....	7-6
Digital Inputs .....	7-6
Digital Outputs .....	7-6
Diagnostic Indications .....	7-6
Terminal Tightening Torque Specifications .....	7-7
DB Resistor Selection .....	7-8
RG Mounting Information .....	7-8
RGA Mounting Information .....	7-8
25M-TR Dimensions .....	7-10
25M-PO Dimensions .....	7-11
Size B Dimensions & Mounting .....	7-11
Size C Dimensions & Mounting .....	7-12
Size D Dimensions & Mounting .....	7-13
25M-PO Mounting Considerations .....	7-14
<b>Appendix A</b> .....	A-1
Parameter Values .....	A-1
<b>Appendix B</b> .....	B-1
Remote Keypad Mounting Template .....	B-2

# Section 1

## Quick Start Guide

---

### Overview

If you are an experienced user of Baldor controls, you are probably already familiar with the keypad programming and keypad operation methods. If so, this quick start guide has been prepared for you. This procedure will help get your system up and running in the keypad mode quickly. This will allow motor and control operation to be verified. This procedure assumes that the Control, Motor and Dynamic Brake hardware are correctly installed (see Section 3 for procedures) and that you have an understanding of the keypad programming & operation procedures. It is not necessary to wire the terminal strip to operate in the Keypad mode (Section 3 describes terminal strip wiring procedures). The quick start procedure is as follows:

1. Read the Safety Notice and Precautions in section 2 of this manual.
2. Mount the control. Refer to Section 3 "Mechanical Installation" procedure.
3. Connect AC power, refer to Section 3 "Power Connections".
4. Connect the external dynamic brake resistor, if required. Refer to Section 3 "Dynamic Brake Resistor".
5. Plug in the keypad, refer to Section 3 "Remote Keypad Installation".
6. Connect the motor, refer to Section 3 "Motor Connections".
7. Connect the encoder, refer to Section 3 "Encoder Installation".

Note: It is not necessary to wire the terminal strip to operate in the Keypad mode.

### **Quick Start Checklist**

1. Verify AC line voltage at the source matches the control rating.
2. Inspect all power connections for accuracy, workmanship and torques as well as compliance to codes.
3. Verify control and motor are grounded to each other and the control is connected to earth ground.
4. Check all signal wiring for accuracy.
5. Be certain all brake coils, contactors and relay coils have noise suppression. This should be an R-C filter for AC coils and reverse polarity diodes for DC coils. MOV type transient suppression is not adequate.

### **Check of Motors and Couplings**

1. Verify freedom of motion for all motor shafts.
2. Verify that all motor couplings are tight without backlash.
3. Verify the holding brakes if any, are properly adjusted to fully release and set to the desired torque value.

---

## **Quick Start Procedure** Initial Conditions

Become familiar with the keypad programming and keypad operation of the control as described in Section 4 of this manual.

1. Verify that any enable inputs to J1B-8 are open.
2. Connect the Keypad to J4 on the 25M panel.
3. Turn power on. Be sure there are no faults.
4. **(PSM-PR only)** Verify PSM "Ready" is ON and the "DB ON" and "Monitor" indicators are OFF. Verify the control "Ready" is ON.
5. **(25M-TR only)** Verify that "Ready" is ON and the "DB" is OFF.
6. Set the Level 1 Input block, Operating Mode to "KEYPAD".
7. Be sure the Level 2 Protection block, Local Enable INP parameter is OFF and the Level 2 Protection block, External Trip parameter is OFF.
8. Enter the following motor data in the Level 2 Motor Data block parameters:  
Motor Voltage (input)  
Motor Rated Amps (FLA)  
Motor Rated Speed (base speed)  
Motor Rated Frequency  
Motor Mag Amps (no load current)  
Encoder Counts
9. At the Level 2 Motor Data block, go to CALC Presets and select YES (using the ▲ key). Press ENTER and let the control calculate the preset values for the parameters that are necessary for control operation.
10. Disconnect the motor from the load (including coupling or inertia wheels). If the load cannot be disconnected, refer to Section 6 and manually tune the control. After manual tuning, perform steps 15 through 19.

**⚠ WARNING: The motor shaft will rotate during the autotune procedure. Be certain that unexpected motor shaft movement will not cause injury to personnel or damage to equipment.**

11. Go to Level 2 Autotune block, and do the following tests:  
CMD OFFSET TRIM  
CUR LOOP COMP  
STATOR R1  
FLUX CUR SETTING  
FEEDBACK TESTS  
SLIP FREQ TEST
12. Remove all power from the control.
13. Couple the motor to its load.
14. Turn power on. Be sure no errors are displayed.
15. Set the Level 2 Output Limits block, "MIN OUTPUT SPEED" parameter.
16. Set the Level 2 Output Limits block, "MAX OUTPUT SPEED" parameter.
17. Go to Level 2 Autotune block, and perform the SPD CNTRLR CALC test.
18. Run the drive from the keypad using one of the following: the arrow keys for direct speed control, keypad entered speed or the JOG mode.
19. Select and program additional parameters to suit your application.

The control is now ready for use in the Keypad mode. If a different operating mode is desired, refer to Section 3 Control Connections and Section 4 Programming and Operation.

## Section 2 General Information

### Introduction

The Baldor 25M control uses flux vector technology in a closed loop control scheme to adjust the frequency and phase of voltage and current applied to a three phase induction motor. The vector control internally separates the motor current into its flux (stator current) and torque producing (rotor current) components. Each current is independently controlled and vectorially added to maintain a 90° phase relationship between them. This produces maximum torque from zero speed to motor base speed. Above motor base speed, the flux component is reduced for constant horsepower operation.

In addition to controlling the current, the frequency must also be controlled. The PWM frequency of the motor signal is calculated based on the slip frequency and the mechanical speed of the rotor. This allows instantaneous adjustment of the voltage and current phasing in response to speed and position feedback from an encoder mounted on the motor shaft.

A keypad interface is used to program the Series 25M parameters to optimize the control for your application. The keypad is used to program the control parameters, set the operating mode, monitor operation status, perform diagnostics, and examine the fault log.

### Sensorless Control

The vector control can also be used as a sensorless control. Simply set the Level 2, Motor Data block, Encoder Counts parameter to a value of zero for sensorless operation.

### 25M-TR Only

Figure 2-1 shows the 25M-TR control and motor configuration. The 25M-TR control is self contained except for external power supplies required for the opto input circuits.

Figure 2-1 25M-TR Control and Motor

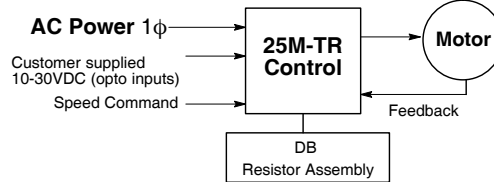

### 25M-PO Only

The 25M AC Flux Vector Control is one member of a family of multi-axis controls. One or more 24M Encoderless Vector, 25M Flux Vector or 26M AC Servo control may be powered from one Power Supply Module (PSM). See Figure 2-2. The PSM converts the AC line power to DC Bus and logic power. The DC Bus power is converted by the 25M control to a three phase signal for proper motor operation. The 25M control should be sized to the motor based on the rated current found on the motor nameplate.

Figure 2-2 Multiple Controls Powered from One PSM

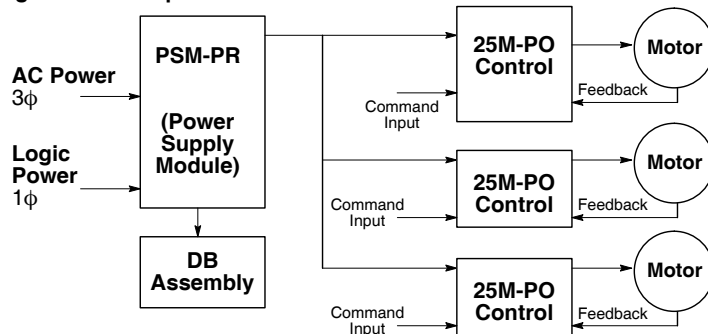



---

### **Limited Warranty**

For a period of two (2) years from the date of original purchase, BALDOR will repair or replace without charge controls which our examination proves to be defective in material or workmanship. This warranty is valid if the unit has not been tampered with by unauthorized persons, misused, abused, or improperly installed and has been used in accordance with the instructions and/or ratings supplied. This warranty is in lieu of any other warranty or guarantee expressed or implied. BALDOR shall not be held responsible for any expense (including installation and removal), inconvenience, or consequential damage, including injury to any person or property caused by items of our manufacture or sale. (Some states do not allow exclusion or limitation of incidental or consequential damages, so the above exclusion may not apply.) In any event, BALDOR's total liability, under all circumstances, shall not exceed the full purchase price of the control. Claims for purchase price refunds, repairs, or replacements must be referred to BALDOR with all pertinent data as to the defect, the date purchased, the task performed by the control, and the problem encountered. No liability is assumed for expendable items such as fuses.

Goods may be returned only with written notification including a BALDOR Return Authorization Number and any return shipments must be prepaid.

---

**Safety Notice:**

This equipment contains high voltages. Electrical shock can cause serious or fatal injury. Only qualified personnel should attempt the start-up procedure or troubleshoot this equipment.

This equipment may be connected to other machines that have rotating parts or parts that are driven by this equipment. Improper use can cause serious or fatal injury. Only qualified personnel should attempt the start-up procedure or troubleshoot this equipment.

**PRECAUTIONS:**

- ⚠ WARNING:** Do not touch any circuit board, power device or electrical connection before you first ensure that power has been disconnected and there is no high voltage present from this equipment or other equipment to which it is connected. Electrical shock can cause serious or fatal injury. Only qualified personnel should attempt the start-up procedure or troubleshoot this equipment.
- ⚠ WARNING:** Be sure that you are completely familiar with the safe operation of this equipment. This equipment may be connected to other machines that have rotating parts or parts that are controlled by this equipment. Improper use can cause serious or fatal injury. Only qualified personnel should attempt the start-up procedure or troubleshoot this equipment.
- ⚠ WARNING:** This unit has an automatic restart feature that will start the motor whenever input power is applied and a RUN (FWD or REV) command is issued. If an automatic restart of the motor could cause injury to personnel, the automatic restart feature should be disabled by changing the Level 2 Miscellaneous block, Restart Auto/Man parameter to Manual.
- ⚠ WARNING:** Be sure all wiring complies with the National Electrical Code and all regional and local codes. Improper wiring may result in unsafe conditions.
- ⚠ WARNING:** Be sure the system is properly grounded before applying power. Do not apply AC power before you ensure that grounds are connected. Electrical shock can cause serious or fatal injury.
- ⚠ WARNING:** Do not remove cover for at least five (5) minutes after AC power is disconnected to allow capacitors to discharge. Electrical shock can cause serious or fatal injury.
- ⚠ WARNING:** Improper operation of control may cause violent motion of the motor shaft and driven equipment. Be certain that unexpected motor shaft movement will not cause injury to personnel or damage to equipment. Peak torque of several times the rated motor torque can occur during control failure.
- ⚠ WARNING:** Motor circuit may have high voltage present whenever AC power is applied, even when motor is not rotating. Electrical shock can cause serious or fatal injury.

Continued on next page

- 
- ⚠ **WARNING:** A DB Resistor may generate enough heat to ignite combustible materials. To avoid fire hazard, keep all combustible materials and flammable vapors away from brake resistors.
  - ⚠ **WARNING:** The motor shaft will rotate during the autotune procedure. Be certain that unexpected motor shaft movement will not cause injury to personnel or damage to equipment.
  - ⚠ **Caution:** Suitable for use on a circuit capable of delivering not more than the RMS symmetrical short circuit amperes listed here at rated voltage.
 

<u>Horsepower</u>	<u>rms Symmetrical Amperes</u>
1–50	5,000
51–200	10,000
201–400	18,000
401–600	30,000
601–900	42,000
  - ⚠ **Caution:** To prevent equipment damage, be certain that the input power has correctly sized protective devices installed as well as a power disconnect.
  - ⚠ **Caution:** Do not connect AC power to the Motor terminals U, V and W. Connecting AC power to these terminals may result in damage to the control.
  - ⚠ **Caution:** Baldor recommends not using “Grounded Leg Delta” transformer power leads that may create ground loops and degrade system performance. Instead, we recommend using a four wire Wye.
  - ⚠ **Caution:** Disconnect motor leads (T1, T2 and T3) from control before you perform a “Megger” test on the motor. Failure to disconnect motor from the control will result in extensive damage to the control. The control is tested at the factory for high voltage / leakage resistance as part of Underwriter Laboratory requirements.
  - ⚠ **Caution:** Avoid locating control immediately above or beside heat generating equipment, or directly below water or steam pipes.
  - ⚠ **Caution:** Avoid locating control in the vicinity of corrosive substances or vapors, metal particles and dust.
  - ⚠ **Caution:** Do not connect any shields to the encoder case or motor frame. The encoder +5VDC supply at J2-4 is referenced to circuit board common. Do not connect any shields to ground or another power supply or damage to the control may result.

## Section 3 Installation

---

### Receiving & Inspection

Baldor Controls are thoroughly tested at the factory and carefully packaged for shipment. When you receive your control, there are several things you should do immediately.

1. Observe the condition of the shipping container and report any damage immediately to the commercial carrier that delivered your control.
2. Remove the control from the shipping container and remove all packing materials. The container and packing materials may be retained for future shipment.
3. Verify that the part number of the control you received is the same as the part number listed on your purchase order.
4. Inspect the control for external physical damage that may have been sustained during shipment and report any damage immediately to the commercial carrier that delivered your control.
5. If the control is to be stored for several weeks before use, be sure that it is stored in a location that conforms to published storage humidity and temperature specifications. (Refer to Section 7 of this manual).

### Location Considerations

The location of the control and Power Supply Module (PSM) is important. Installation should be in an area that is protected from direct sunlight, corrosives, harmful gases or liquids, dust, metallic particles, and vibration. Exposure to these can reduce the operating life and degrade performance of the control.

Several other factors should be carefully evaluated when selecting a location for installation:

1. For effective cooling and maintenance, the control and PSM should be mounted on a smooth, non-flammable vertical surface. The amount of heat generated within the control can be calculated based on Table 3-1.
2. At least two inches top and bottom clearance must be provided for air flow.
3. **Altitude derating.** Up to 3300 feet (1000 meters) no derating required. Derate the continuous and peak output current by 2% for each 1000 feet (300 meters) above 3300 feet.
4. **Temperature derating.** From 0°C to 40°C ambient no derating required. Above 40°C, derate the continuous and peak output current by 2% per °C above 40°C. Maximum ambient is 60°C.

**Table 3-1 Control Watts Loss Ratings**

25M-TR		25M-PO		PSM-PR	
115 VAC	230 VAC	230 VAC	460 VAC	230 VAC	460 VAC
3.5 Watts/ Amp	10 Watts/ Amp	10 Watts/ Amp	17 Watts/ Amp	10 Watts/ Amp	17 Watts/ Amp

---

**Mechanical Installation****(25M-TR Only)**

Mount the control to the mounting surface. The control must be securely fastened to the mounting surface. Use the four (4) mounting holes to fasten the control to the mounting surface or enclosure. The location of the mounting holes are shown in Section 7 of this manual.

**Mechanical Installation**

**(25M-PO Only)** Mount the PSM (Power Supply Module) and the control to the mounting surface.

**PSM Procedure**

The PSM must be securely fastened to the mounting surface. Use the four (4) mounting holes to fasten the PSM to the mounting surface or enclosure. The location of the mounting holes are shown in Section 7 of this manual.

**Control Procedure**

The control must be securely fastened to the mounting surface. Use the four (4) mounting holes to fasten the control to the mounting surface or enclosure. The location of the mounting holes are shown in Section 7 of this manual.

**Through Wall Mounting** The PSM and control module are designed for panel or through wall installation.

**Procedure:**

1. Refer to Section 7 of this manual for drawings and dimensions for through the wall mounting. Use the information contained in these drawings to layout the appropriate size hole on your enclosure and wall.
2. Cut the holes in your enclosure and wall.
3. Locate and drill holes for mounting hardware as shown in the drawings.
4. Secure the four (4) brackets to the exterior of the customers panel with the hardware provided.
5. Secure the control to the customers panel using the hardware provided.

**Keypad Installation****(PO and TR systems)****Procedure:**

1. Refer to the Remote Keypad Installation procedure and mount the keypad.
2. Connect the cable for the keypad assembly to J4 of the control.

---

**Remote Keypad Installation** The keypad may be remotely mounted using the optional Baldor keypad extension cable. The keypad assembly (grey - DC00005A-02) comes complete with the screws and gasket required to mount it to an enclosure. When the keypad is properly mounted to a NEMA Type 4 indoor enclosure, it retains the Type 4 indoor rating.

**Tools Required:**

- Center punch, tap handle, screwdrivers (Phillips and straight) and crescent wrench.
- 8-32 tap and #29 drill bit (for tapped mounting holes) or #19 drill (for clearance mounting holes).
- 1-1/4" standard knockout punch (1-11/16" nominal diameter).
- RTV sealant.
- (4) 8-32 nuts and lock washers.
- Extended 8-32 screws (socket fillister) are required if the mounting surface is thicker than 12 gauge and is not tapped (clearance mounting holes).
- Remote keypad mounting template. A tear out copy is provided at the end of this manual for your convenience.

**Mounting Instructions: For tapped mounting holes**

1. Locate a flat 4" wide x 5.5" minimum high mounting surface. Material should be sufficient thickness (14 gauge minimum).
2. Place the template on the mounting surface or mark the holes as shown.
3. Accurately center punch the 4 mounting holes (marked A) and the large knockout (marked B).
4. Drill four #29 mounting holes (A). Thread each hole using an 8-32 tap.
5. Locate the 1-1/4" knockout center (B) and punch using the manufacturers instructions.
6. Debur knockout and mounting holes making sure the panel stays clean and flat.
7. Apply RTV to the 4 holes marked (A).
8. Assemble the keypad to the panel. Use 8-32 screws, nuts and lock washers.
9. From the inside of the panel, apply RTV over each of the four mounting screws and nuts. Cover a 3/4" area around each screw while making sure to completely encapsulate the nut and washer.

**Mounting Instructions: For clearance mounting holes**

1. Locate a flat 4" wide x 5.5" minimum high mounting surface. Material should be sufficient thickness (14 gauge minimum).
2. Place the template on the mounting surface or mark the holes as shown on the template.
3. Accurately center punch the 4 mounting holes (marked A) and the large knockout (marked B).
4. Drill four #19 clearance holes (A).
5. Locate the 1-1/4" knockout center (B) and punch using the manufacturers instructions.
6. Debur knockout and mounting holes making sure the panel stays clean and flat.
7. Apply RTV to the 4 holes marked (A).
8. Assemble the keypad to the panel. Use 8-32 screws, nuts and lock washers.
9. From the inside of the panel, apply RTV over each of the four mounting screws and nuts. Cover a 3/4" area around each screw while making sure to completely encapsulate the nut and washer.

## Electrical Installation

All interconnection wires between the control, AC power source, motor, host control and any operator interface stations should be in metal conduits. Use listed closed loop connectors that are of appropriate size for wire gauge being used. Connectors are to be installed using crimp tool specified by the manufacturer of the connector. Only Class 1 wiring should be used.

## System Grounding

Baldor Controls are designed to be powered from standard three phase lines that are electrically symmetrical with respect to ground. System grounding is an important step in the overall installation to prevent problems. The recommended grounding method is shown in Figure 3-1 and 3-2.

**Figure 3-1 Recommended System Grounding (PSM-PR)**

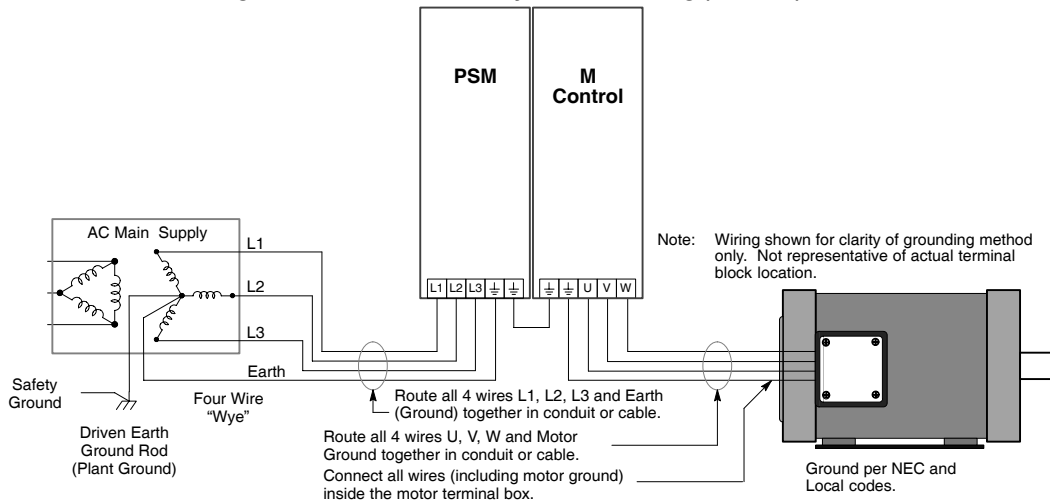

**Figure 3-2 Recommended System Grounding (25M-TR)**

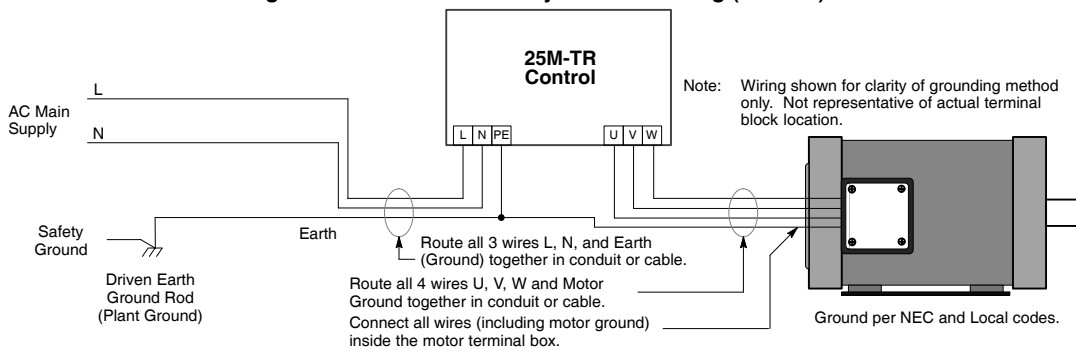

**Ungrounded Distribution System**

With an ungrounded power distribution system it is possible to have a continuous current path to ground through the MOV devices. To avoid equipment damage, an isolation transformer with a grounded secondary is recommended. This provides three phase AC power that is symmetrical with respect to ground.

**Input Power Conditioning**

Baldor controls are designed for direct connection to standard three phase lines that are electrically symmetrical with respect to ground. Certain power line conditions must be avoided. An AC line reactor or an isolation transformer may be required for some power conditions.

- If the feeder or branch circuit that provides power to the control has permanently connected power factor correction capacitors, an input AC line reactor or an isolation transformer must be connected between the power factor correction capacitors and the control.
- If the feeder or branch circuit that provides power to the control has power factor correction capacitors that are switched on line and off line, the capacitors must not be switched while the control is connected to the AC power line. If the capacitors are switched on line while the control is still connected to the AC power line, additional protection is required. TVSS (Transient Voltage Surge Suppressor) of the proper rating must be installed between the AC line reactor or an isolation transformer and the AC input to the control.

**Line Impedance**

The Baldor control requires a minimum 3% line impedance. If the impedance of the incoming power does not meet the requirement for the control, a 3 phase line reactor can be used to provide the needed impedance in most cases. Line reactors are optional and are available from Baldor.

The input impedance of the power lines can be determined as follows:

Measure the line to line voltage at no load and at full rated load.  
Use these measured values to calculate impedance as follows:

$$\% \text{Impedance} = \frac{(\text{Volts}_{\text{No Load Speed}} - \text{Volts}_{\text{Full Load Speed}})}{(\text{Volts}_{\text{No Load Speed}})} \times 100$$

**Line Reactors**

Three phase line reactors are available from Baldor. The line reactor to order is based on the full load current of the motor (FLA). If providing your own line reactor, use the following formula to calculate the minimum inductance required.

$$L = \frac{(V_{L-L} \times 0.03)}{(I \times \sqrt{3} \times 377)}$$

Where: L Minimum inductance in Henries.  
V<sub>L-L</sub> Input volts measured line to line.  
0.03 Desired percentage of input impedance.  
I Input current rating of control.  
377 Constant used with 60Hz power.  
Use 314 if input power is 50Hz.

**Load Reactors**

Line reactors may be used at the control output to the motor. When used this way, they are called Load Reactors. Load reactors serve several functions that include:

- Protect the control from a short circuit at the motor.
- Limit the rate of rise of motor surge currents.
- Slowing the rate of change of power the control delivers to the motor.

Load reactors should be installed as close to the control as possible. Selection should be based on the motor nameplate FLA value.



**Power Disconnect**

A power disconnect should be installed between the input power service and the PSM-PR (Power Supply Module) or 25M-TR control for a fail safe method to disconnect power. The control will remain in a powered-up condition until all input power is removed from the control and the internal bus voltage is depleted. The PSM-PR should also have a power disconnect means installed in the 1 phase logic power supply.

**Protection Devices**

The PSM-PR or 25M-TR control must have a suitable input power protection device installed. Input and output wire size is based on the use of copper conductor wire rated at 75 °C. Use the recommended circuit breaker or fuse types as follows:

- Circuit Breaker: 1 phase, thermal magnetic.  
Equal to GE type THQ or TEB for 115 or 230 VAC
- 3 phase, thermal magnetic.  
Equal to GE type THQ or TEB for 230 VAC or  
GE type TED for 460 VAC.
- Fast Action Fuses: Buss KTN on 230 VAC or  
Buss KTS on 460 VAC, Buss FRS or equivalent.
- Time Delay Fuses: Buss FRN on 230 VAC or  
Buss FRS on 460 VAC or equivalent.

Table 3-2 describes the wire size to be used for power connections and the ratings of the protection devices.

Recommended fuse sizes are based on the following:

- 115% of maximum continuous current for time delay fuses.
- 150% of maximum continuous current for fast or very fast acting fuses.

**Table 3-2 Wire Size and Protection Devices**

Catalog Number	L1, L2, L3 Incoming Power						X3 Logic Power		
	Maximum Continuous Amps	Input Breaker	Input Fuse		Wire Gauge		Input Fuse	Wire Gauge	
			Fast Acting	Time Delay	AWG	mm <sup>2</sup>		AWG	mm <sup>2</sup>
ZD25M1A02-TR	2.5A	5A	4A	4A	14	2.08			
ZD25M1A05-TR	5A	7.5A	7.4A	6.7A	14	2.08			
ZD25M2A02-TR	2.5A	5A	4A	4A	14	2.08			
ZD25M2A05-TR	5A	7.5A	7.4A	6.7A	14	2.08			
PSM2A060-PR1	60A	90A	90A	70A	6	13.3	Internal	16	1.0
PSM2A060-PR2	60A	90A	90A	70A	6	13.3	Internal	16	1.0
PSM2A100-PR1	100A	150A	150A	115A	3	26.7	Internal	16	1.0
PSM2A100-PR2	100A	150A	150A	115A	3	26.7	Internal	16	1.0
PSM4A030-PR1	30A	50A	50A	40A	8	8.37	Internal	16	1.0
PSM4A030-PR2	30A	50A	50A	40A	8	8.37	Internal	16	1.0
PSM4A050-PR1	50A	70A	80A	60A	6	13.3	Internal	16	1.0
PSM4A050-PR2	50A	70A	80A	60A	6	13.3	Internal	16	1.0
PSM4A100-PR1	100A	125A	150A	110A	1	42.4	Internal	16	1.0
PSM4A100-PR2	100A	125A	150A	110A	1	42.4	Internal	16	1.0

Note: All wire sizes are based on 75°C copper wire, 3% line impedance. Higher temperature smaller gauge wire may be used per NEC and local codes. Recommended fuses/breakers are based on 25°C ambient, maximum continuous control output current and no harmonic current.

## Power Connections

Power connections are shown in Figure 3-3 or Figure 3-4.

### Figure 3-3 Single Phase AC Power and Motor Connections (25M-TR Only)

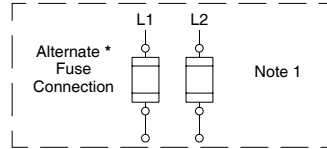
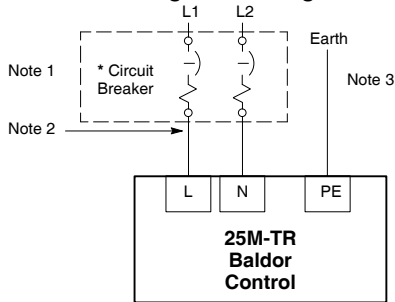

\* Components not provided with PSM or Control.

See Recommended Tightening Torques in Section 7.

Notes:

1. See "Protection Devices" described in this section.
2. Metal conduit should be used. Connect conduits so the use of a Reactor or RC Device does not interrupt EMI/RFI shielding.
3. Use same gauge wire for Earth ground as is used for L and N.

### Figure 3-4 3 Phase Power and Motor Connections (PSM-PR and 25M-PO Only)

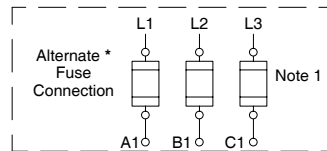
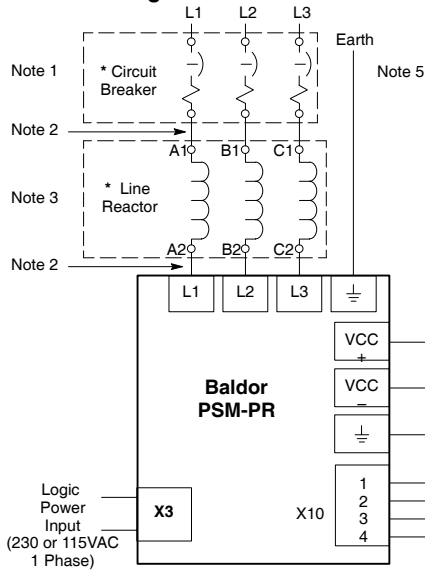

\* Components not provided with PSM or Control.

See Recommended Tightening Torques in Section 7.

Notes:

1. See Protection Device description in this section.
2. Metal conduit should be used. Connect conduits so the use of a Reactor or RC Device does not interrupt EMI/RFI shielding.
3. See Line Impedance in this section.
4. Refer to Motor Connections in this section.
5. Use the same gauge wire for Earth as used for L1, L2, L3 connections.

#### Important:

Be sure to connect the proper voltage for X3 Logic Power input. Look at the last digit of the identification number to determine voltage:

PSMXXXX-PR1 = 115VAC  
PSMXXXX-PR2 = 230VAC

**Figure 3-5 Copper Bus Bar Installation (PSM-PR and 25M-PO Only)**

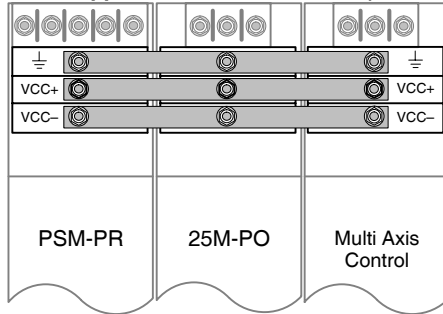

Refer to Section 7 for information on Bus Bars and installation spacing information.

See Terminal Tightening Torques in Section 7 of this manual.

**Figure 3-6 25M-TR Connector Locations**

**X1 - Power Connector**

⊥	Earth	} Input Power
NC	No Connection	
L	AC Line	
N	Neutral	
U	Motor lead "U"	} Motor
V	Motor lead "V"	
W	Motor lead "W"	
R1	Dynamic Brake	} Dynamic Brake or Regen Resistor
R2	Dynamic Brake	
+24V External	+24VDC Input	} +24VDC Input
0V Supply	24V Common	

**J1B - Digital I/O**

8	Enable	18	+24VDC
9	FWD CMD	19	CREF (OPTO IN)
10	REV CMD	20	OUT1-
11	IN1	21	OUT1+
12	IN2	22	OUT2-
13	IN3	23	OUT2+
14	IN4	24	OUT3-
15	IN5	25	OUT3+
16	External Trip	26	OUT4-
17	24V Return	27	OUT4+

**J1A - Analog I/O**

1	AGND	5	ANA IN 2-
2	ANA IN 1	6	ANA OUT1
3	Reference	7	ANA OUT2
4	ANA IN 2+		

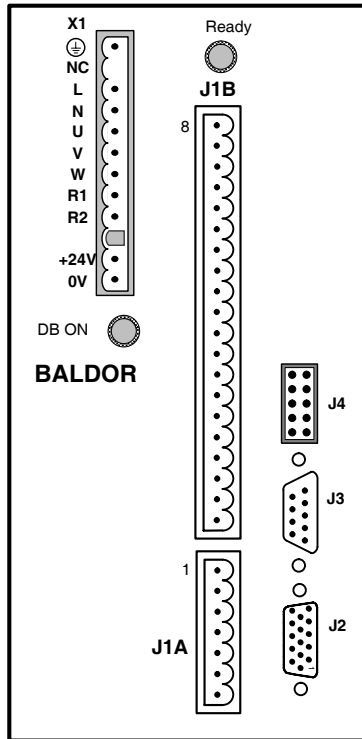

**J4 - Keypad**

1	Shield	6	RCV-
2	N.C.	7	N.C.
3	XMIT+	8	N.C.
4	XMIT-	9	+8VDC
5	RCV+	10	DGND

**J3 - Buffered Encoder Output**

1	CHA+	6	CHA-
2	CHB+	7	CHB-
3	CHC+	8	CHC-
4	N.C.	9	N.C.
5	DGND		

**J2 - Encoder Input - 15 pin**

1	CHA+	6	CHA-	11	+5VDC
2	CHB+	7	CHB-	12	NC
3	CHC+	8	CHC-	13	DGND
4	U+	9	W+	14	W-
5	U-	10	V+	15	V-

**Figure 3-7 PSM-PR Power Supply Connector Locations**

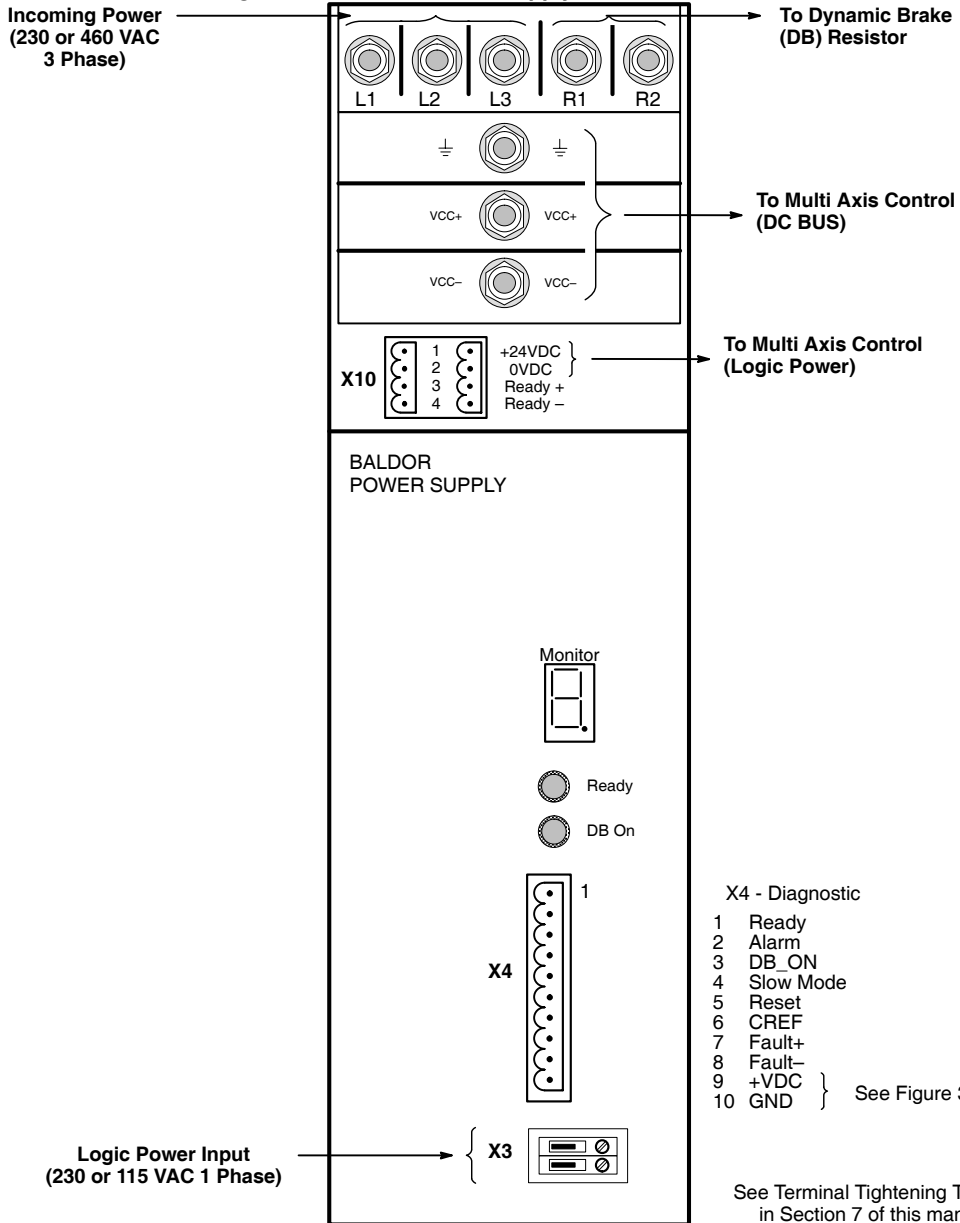

**Figure 3-8 25M-PO Vector Connector Locations**

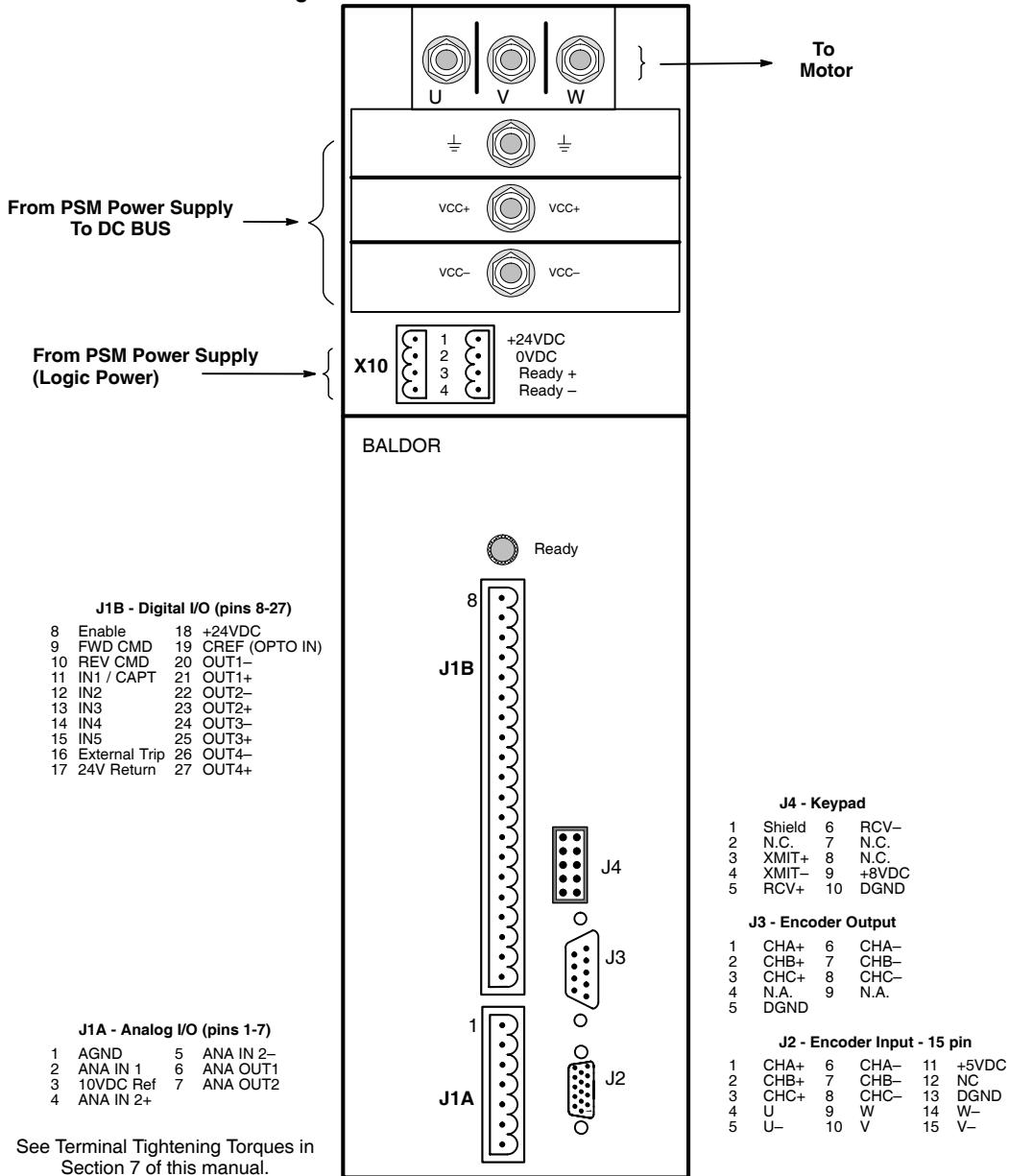

---

## Optional PSM-PR I/O Connections – (PSM-PR Only)

Connector X4 contains the interface input and output connections for the PSM (Power Supply Module). Connection to the X4 I/O terminal strip is optional. No connections are required for normal operation. However, to monitor PSM status or to “Reset” the PSM you may make some or all of these optional connections.

### Status monitor output connections (Opto Isolated Outputs)

Status monitor output connections are shown in Figure 3-9. The output signals (X4-1, 2 and 3) can then be connected to an external device (referenced to X4-10). These internal contacts close when active and apply the voltage +24VDC at the output.

The Alarm Output (X4-2) activates immediately when one of the following faults occur: Loss of AC Power, Phase Loss (AC input), Loss of Logic Power, Bus Undervoltage, Overtemperature or Dynamic Brake fault. The other Status Monitor outputs (X4-1 and 3) have a 100ms delay before activation.

Note: The maximum current draw when all three outputs are active must not exceed 100mA.

**Figure 3-9 Status Monitor Output Connections**

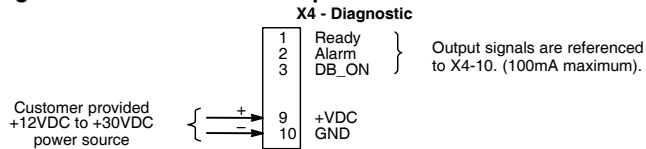

### Reset connection

Connection of the Reset input is shown in Figure 3-10. This is useful to reset the control after a fault condition. The reset input voltage is +24VDC (12 to 30VDC @ 10mA) and must be applied for at least 60  $\mu$ s.

**Figure 3-10 Reset Input**

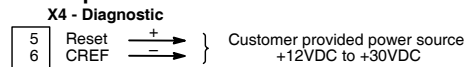

### Fault Relay connection

Fault Relay connection is shown in Figure 3-11. The fault relay output can be connected to an external relay or other device. This internal normally closed contact opens when a fault condition occurs. The fault list is the same as for the Alarm Output.

**Figure 3-11 Fault Relay**

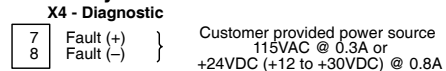

**Motor Connections**

Motor connections are shown in Figure 3-12.

**Figure 3-12 Motor Connections**

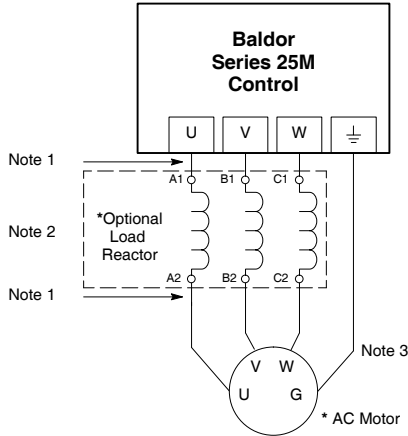

Notes:

1. Metal conduit should be used. Connect conduits so the use of Load Reactor or RC Device does not interrupt EMI/RFI shielding.
2. See Line/Load Reactors described previously in this section.
3. Use same gauge wire for Earth ground as for L and N or L1, L2 and L3.

\* Optional components not provided with control.

See Recommended Tightening Torques in Section 7.

**M-Contactor**

If required by local codes or for safety reasons, an M-Contactor (motor circuit contactor) may be installed. However, incorrect installation or failure of the M-contactor or wiring may damage the control. If an M-Contactor is installed, the control must be disabled for at least 20msec before the M-Contactor is opened or the control may be damaged. M-Contactor connections are shown in Figure 3-13.

**Figure 3-13 Optional M-Contactor Connections**

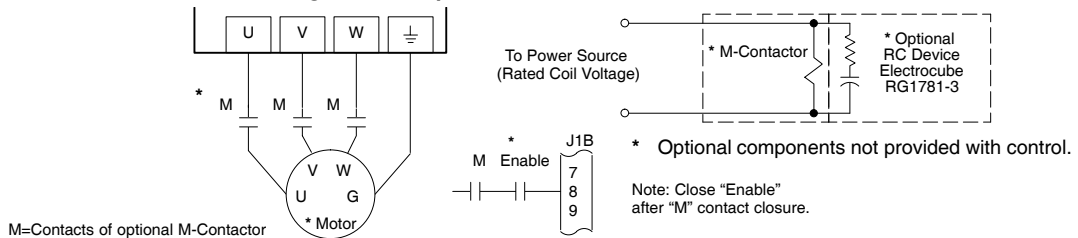

M=Contacts of optional M-Contactor

**Dynamic Brake Resistor**

An external DB (Dynamic Brake) resistor must be installed to dissipate excess power from the DC bus during motor deceleration operations. For selection of the DB resistor, refer to the specifications located in Section 7 of this manual. DB hardware is connected at DB+ and DB- (25M-TR) or at R1 and R2 terminals (PSM-PR Power Supply).

**Encoder Installation**

Electrical isolation of the encoder shaft and housing from the motor is required. Electrical isolation prevents capacitive coupling of motor noise that will corrupt the encoder signals. Baldor provides shielded wire for encoder connection. Figure 3-14 shows the electrical connections between the encoder and the encoder connector.

**Figure 3-14 Differential Encoder Connections**

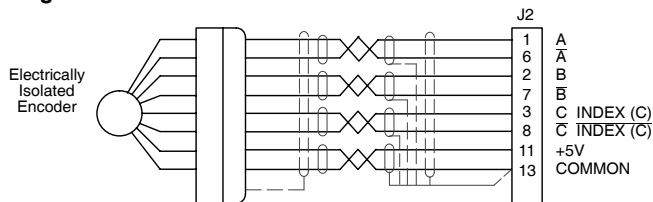

**Single Ended Connections**

Differential inputs are recommended for best noise immunity. If only single ended encoder signals are available, connect them to A, B, and INDEX (C) (J2-1, J2-2-2 and J2-3 respectively). A-bar, B-bar, and INDEX (C-bar) are then connected to common at J2-13 as shown in Figure 3-15.

**Figure 3-15 Single Ended Encoder Connections**

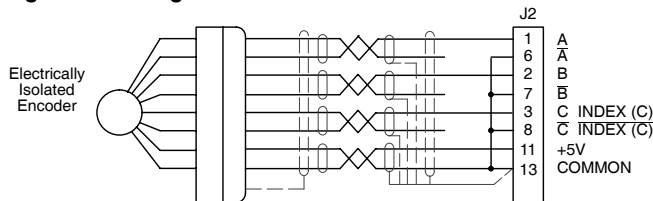

**Home (Orient) Switch Input** The Home or Orient function causes the motor shaft to rotate to a predefined home position. The homing function allows shaft rotation in the drive forward direction only. The home position is located when a machine mounted switch or the encoder "Index" pulse is activated (closed). Home is defined by a rising signal edge at terminal J2-3. The shaft will continue to rotate only in a "Drive Forward" direction for a user defined offset value. The offset is programmed in the Level 2 Miscellaneous Homing Offset parameter. The speed at which the motor will "Home" or orient is set with the Level 2 Miscellaneous Homing Speed parameter.

A machine mounted switch may be used to define the Home position in place of the encoder index channel. A differential line driver output from a solid state switch is preferred for best noise immunity. Connect this differential output to terminals J2-3 and J2-8.

A single ended solid-state switch or limit switch should be wired as shown in Figure 3-16. Regardless of the type of switch used, clean rising and falling edges at J2-3 are required for accurate positioning.

Note: A control may require dynamic brake hardware for Orient (Homing) function to work. The control may trip without dynamic brake hardware installed.

**Figure 3-16 Typical Home or Orient Switch Connections**

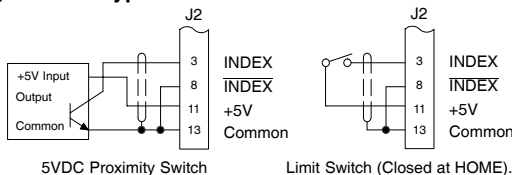

**Buffered Encoder Output** The control provides a buffered encoder output on connector J3. This output may be used by external hardware to monitor the encoder signals. It is recommended that this output only drive one circuit load (a 26LS31 type device drives this output).



---

## Analog Inputs and Outputs

### Analog Inputs

Two analog inputs are available: Analog Input #1 (J1A-1 and J1A-2) and Analog Input #2 (J1A-4 and J1A-5) as shown in Figure 3-17. Either analog input #1 or #2 may be grounded provided the common mode range is not exceeded. Either analog input may be selected in the Level 1 INPUT block, Command Select parameter value. Analog input #1 is selected if parameter value "Potentiometer" is selected. Analog input #2 is selected if parameter value "+/-10Volts, +/-5 Volts or 4-20mA" is selected.

Note: Bipolar input signals ( $\pm 5\text{VDC}$  and  $\pm 10\text{VDC}$ ) are used in Bipolar and Process Control modes only. Other modes use 0-5VDC and 0-10VDC input signals.

**Figure 3-17 Analog Inputs and Outputs**

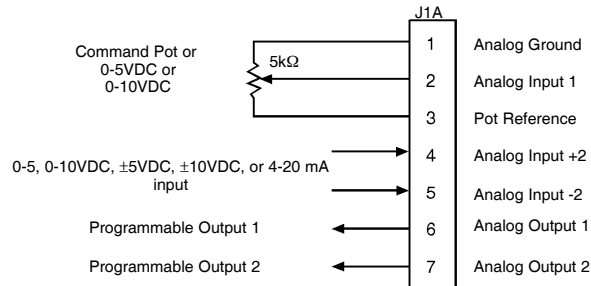

### Analog Input #1 (Single Ended)

The single ended analog input #1 is used when the controller is set to Standard Run 3 Wire, 3 SPD ANA 2Wire, 3 SPD ANA 3Wire, Serial, Process Control, EPOT-2 Wire or EPOT-3 Wire (not Keypad or 15 Speed).

Note: A potentiometer value of  $5\text{k}\Omega$  to  $10\text{k}\Omega$ , 0.5 watt may be used.

The single ended analog input #1 can be used in one of three ways. Speed command (Level 1 Input block, Command Select=Potentiometer). Process Feedback (Level 2 Process Control block, Process Feedback=Potentiometer). Setpoint Source (Level 2 Process Control block, Setpoint Source=Potentiometer).

When using Analog Input #1, the respective parameter must be set to "POTENTIOMETER".

### Analog Input #2 (Differential)

Analog input #2 accepts a 0-5VDC, 0-10VDC or 4-20 mA command in all modes and  $\pm 5\text{VDC}$ ,  $\pm 10\text{VDC}$ , 0-5VDC, 0-10VDC or 4-20 mA in Bipolar and Process Control modes. The operating mode is defined in the Level 1 Input block OPERATING MODE parameter.

Note: Analog Input #2 is used with Standard Run 3-Wire, Fan Pump 2 Wire, Fan Pump 3 Wire, Process Control, 3 SPD ANA 2Wire, 3 SPD ANA 3Wire, EPOT-2 Wire or EPOT-3 Wire (not Keypad, 15 Speed or Serial modes).

Note: Analog Input #2 can be connected for single ended operation by grounding either of the inputs, if the common mode voltage range is not exceeded. The common mode voltage can be measured with a voltmeter. Apply the maximum command voltage to analog input 2 (J1A-4, 5). Measure the AC and DC voltage across J1A-1 to J1A-4. Add the AC and DC readings together. Measure the AC and DC voltage from J1A-1 to J1A-5. Add the AC and DC readings together.

If either of these measurement totals exceeds a total of  $\pm 15$  volts, then the common mode voltage range has been exceeded. If the common mode voltage range has been exceeded, the solution is either to change the command voltage source or isolate the command voltage with a commercially available signal isolator.

**Figure 3-18 Analog Inputs Equivalent Circuits**

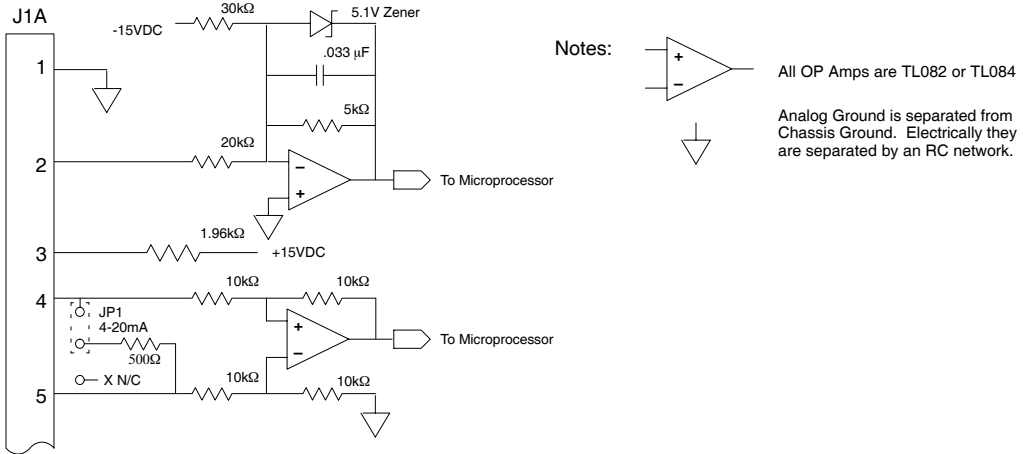

**Figure 3-19 Jumper Locations**

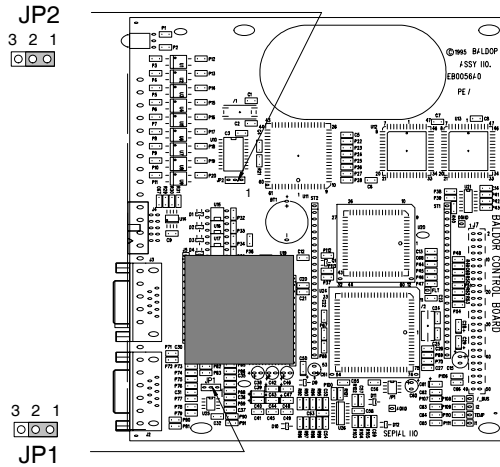

Refer to Table 3-3 for jumper position information.

**Table 3-3 Jumper Positions**

Jumper	Jumper Position	Description of Jumper Position Setting
JP1	1-2	Voltage Command Signal. (Factory Setting)
	2-3	4-20mA Command Signal.
JP2	1-2	Do Not Move (Factory Setting)
	2-3	Not used.

## Analog Outputs

Two programmable analog outputs are provided on J1A-6 and J1A-7. The output conditions are defined in Section 4 of this manual. The actual output voltage for each analog output condition can be 0-10VDC or  $\pm 10$ VDC depending upon the output condition selected (1mA maximum output current) and can provide real-time status of various control conditions. The output conditions are defined in Section 4 of this manual.

The return for these outputs is J1A-1 analog ground. Each output is programmed in the Level 1 Output block.

**Figure 3-20 Analog Outputs Equivalent Circuits**

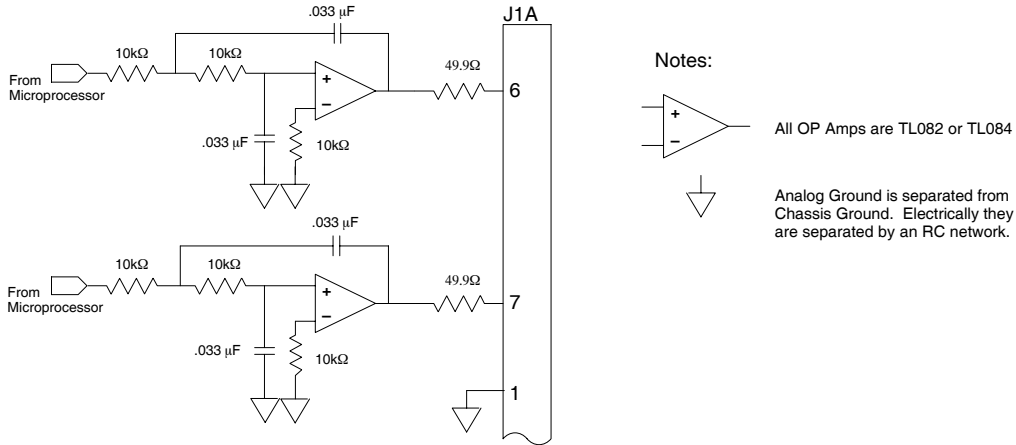

## External Trip Input

Terminal J1B-16 is available for connection to a normally closed thermostat or overload relay contact in all operating modes as shown in Figure 3-21. The thermostat or overload relay should be a dry contact type with no power available from the contact. If the motor thermostat or overload relay activates, the control will automatically shut down and give an External Trip fault. The optional relay (CR1) shown provides the isolation required and the N.O. contact is closed when power is applied to the relay and the motor is cold.

The optional relay (CR1) shown provides the isolation required. The N.O. contact shown is closed when power is applied to the relay and the motor is cold.

Connect the External Trip Input wires to J1B-16 and J1B-17 (or  $GND_{ext}$ ). Do not place these wires in the same conduit as the motor power leads.

To activate the External Trip input, the External Trip parameter in the programming Protection Block must be set to "ON".

**Figure 3-21 Motor Temperature Relay**

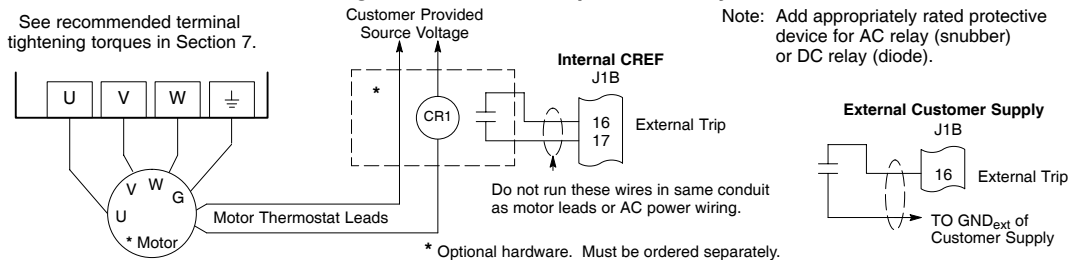

**Figure 3-22 Opto-Input Equivalent Circuit (using external supply)**

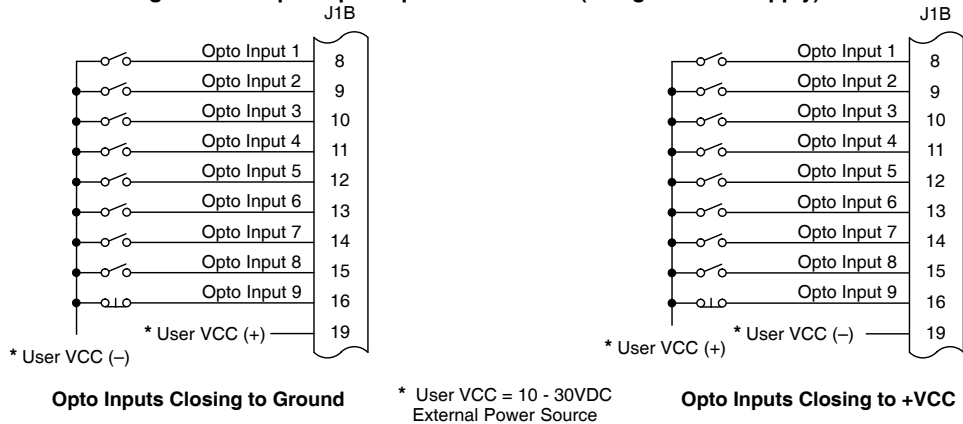

**Opto-Isolated Outputs**

Four programmable Opto-isolated outputs are available at terminals J1B-20 through J1B-27. See Figure 3-23.

The Opto-isolated outputs may be configured for sinking or sourcing 50 mA each. However, all must be configured the same. The maximum voltage from opto output to common when active is 1.0 VDC (TTL compatible). The Opto-isolated outputs may be connected in different ways as shown in Figure 3-23.

If the opto outputs are used to directly drive a relay, a flyback diode rated at 1A, 100 V (1N4002) minimum should be connected across the relay coil. See Electrical Noise Considerations in Section 5 of this manual.

Each Opto Output is programmed in the Level 1 Output programming block.

**Figure 3-23 Opto-isolated Output Configurations**

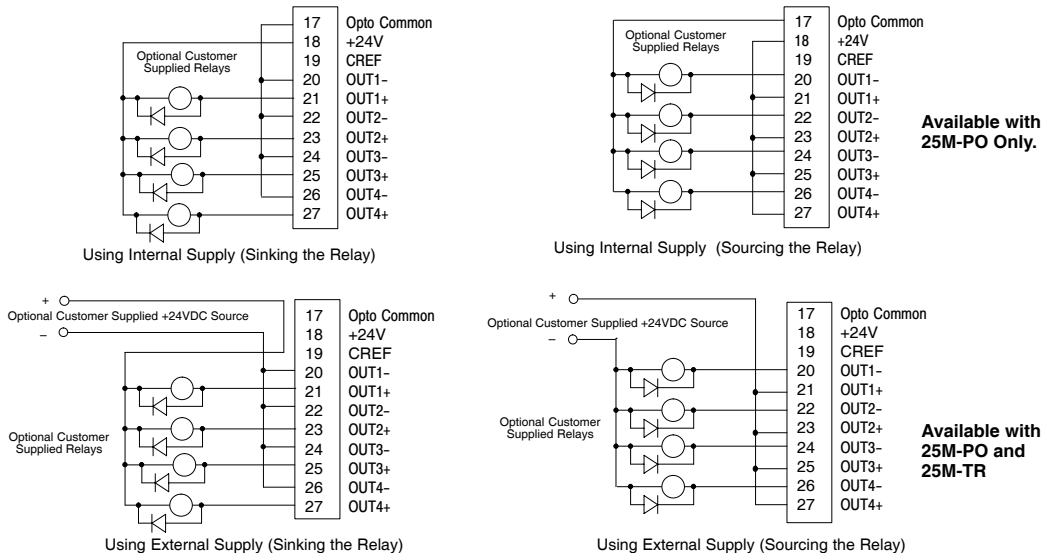

**Control Circuit Connections** The operating modes define the basic motor control setup and the operation of the input and output terminals. After the circuit connections are completed, the operating mode is selected by programming the operating mode parameter in the Level 1 Input programming block. Operating modes are:

- Keypad Mode
- Standard Run 3 Wire Mode (e.g. Potentiometer)
- 15 Speed 2 Wire Mode (e.g. Preset Speeds)
- 3 Speed Analog 2 Wire Mode
- 3 Speed Analog 3 Wire Mode
- Serial
- Bipolar Speed or Torque Mode (e.g.  $\pm 10\text{VDC}$ ,  $\pm 5\text{VDC}$  or 4-20mA)
- Process Control
- Electronic Pot 2 Wire Mode
- Electronic Pot 3 Wire Mode

**Opto Isolated Inputs**

Logic input connections are made at terminal strip J1B pins 8, 9, 10, 11, 12, 13, 14, 15, and 16. Input connections at J1B can be wired as active High or active Low as shown in Figure 3-24. J1B pin 19 is the Control Reference point (CREF) for the Opto Isolated Input signals.

**Active High (Sourcing)** - If pin 19 is grounded, an input is active when it is at +24VDC (+10VDC to +30VDC).

**Active Low (Sinking)** - If pin 19 is at +24VDC (+10VDC to +30VDC), an input is active when it is grounded.

Note: **(25M-PO Only)** The internal 24VDC power supply can be used to power the the Opto Input circuits by connecting a jumper between CREF J1B pin 19 to J1B pin 17 or 18. This provides GND or 24VDC at CREF for Active Low or High input conditions.

As an alternative, an external power supply can be used and connected as shown in Figure 3-24.

Note: **(25M-TR Only)** An internal 24VDC power supply is not available to power the the Opto Input circuits. An external power source must be used as shown in Figure 3-24.

**Figure 3-24 Active HIGH (Sourcing)/LOW (Sinking) Relationship**

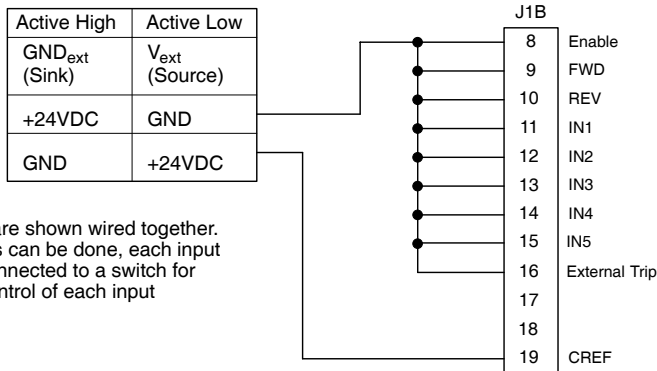

Note: These pins are shown wired together. Although this can be done, each input is usually connected to a switch for individual control of each input condition.

## 25M Operating Mode Configurations

### Opto Input Switch Power Connections

The main difference in the connection of a 25M-TR and a 25M-PO is that the 25M-TR requires an external power supply. The 25M-PO can use the internal or an external power supply. Refer to the examples shown in Figure 3-25.

**Figure 3-25 Connection Diagram Examples**

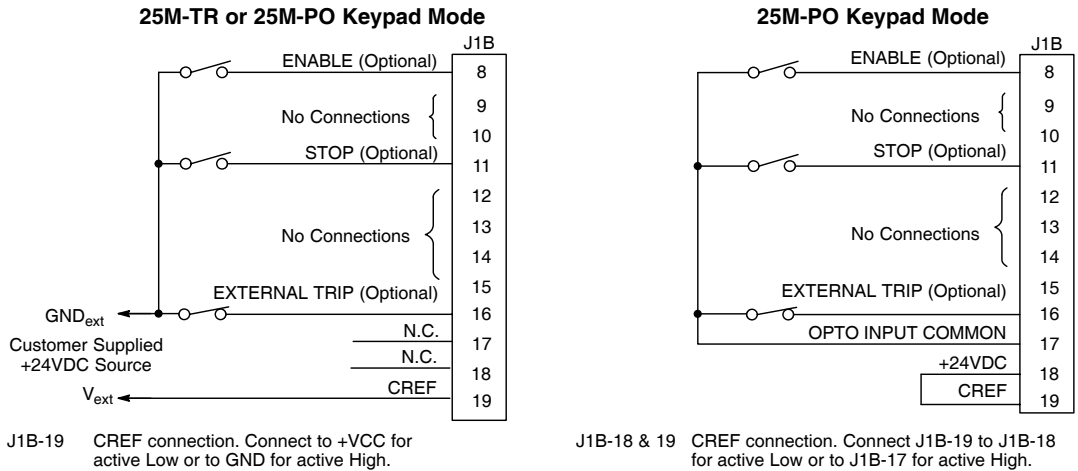

### Serial Operating Mode

The Serial operating mode requires the optional Serial Interface expansion board. Refer to MN1306 for more information about expansion boards for Series M controls.

**25M Operating Mode Configurations** Continued

**Keypad Operating Mode** (see Figure 3-26)

The Keypad operating mode allows the control to be operated from the keypad. In this mode no control connection wiring is required. However, the Enable and External Trip inputs may optionally be used. All other opto inputs remain inactive. However, the analog outputs and opto-outputs remain active at all times. To use an opto input, the associated parameter value must set.

For operation in Keypad mode, set the Level 1 Input block, Operating mode parameter to Keypad. At the keypad press the LOCAL key to change between the LOCAL and REMOTE modes. The word "LOCAL" or "Remote" should appear on the keypad display.

The STOP key can operate in two ways:

- Press STOP key one time to brake or coast to stop.
- Press STOP key two times to disable control.

**The Enable input is optional.**

To use the Enable input, J1B-8 must be connected and the Local Enable INP parameter in the Level 2 Protection block must be set to ON. The Enable line is normally closed. When opened, the motor will COAST to a stop. When the enable line is again closed, the motor will not start until a new direction command is received from the keypad (▲ or ▼ key).

**The Stop input is optional.**

To use the Stop input, J1B-11 must be connected to the opto input common and the Loc. Hot Start parameter in the Level 1 Keypad Setup block must be set to ON. The Stop line is normally connected to the opto input common for normal operation. When this line is opened, the motor will coast or brake to a stop and the control is disabled. The motor will restart when J1B-11 is closed (to opto input common) after open.

**The External Trip input is optional.**

The External Trip input is used to cause a fault condition during a motor over temperature condition. The External Trip input (J1B-16) must be connected and the External Trip parameter in the Level 2 Protection block must be set to "ON". When J1B-16 is opened, the motor will coast to a stop and an External Trip fault is displayed on the keypad.

**Figure 3-26 Keypad Mode Connection Diagram**

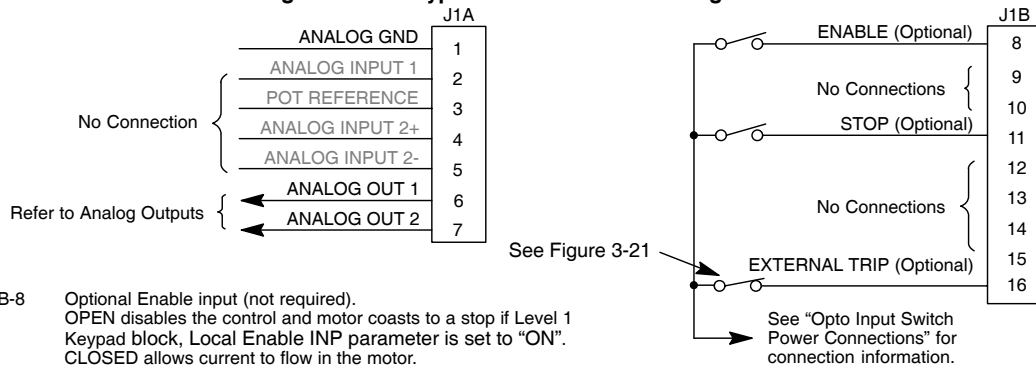

- J1B-8 Optional Enable input (not required). OPEN disables the control and motor coasts to a stop if Level 1 Keypad block, Local Enable INP parameter is set to "ON". CLOSED allows current to flow in the motor.
- J1B-11 Optional STOP input (not required). OPEN motor coasts or brakes to a stop if Level 1 Keypad block, Local Hot Start parameter is set to "ON". Motor will restart when switch closes after open. CLOSED allows current to flow in the motor.
- J1B-16 Optional External Trip input (not required). If used, you must set Level 2 Protection block, External Trip to "ON". OPEN causes an External Trip to be received by the control (when programmed to "ON"). When this occurs, the drive disables, drive "Ready" LED goes out and an external trip fault is displayed on the keypad display (also logged into the fault log).

**25M Operating Mode Configurations** Continued

**Standard Run 3 Wire Mode** The motor speed command may be Preset Speed (J1B-14), Analog Input #1 (5kΩ pot) or Analog Input #2.

In standard run mode, the control is operated by the Opto Isolated inputs at J1B-8 through J1B-16 and the analog command input (5kΩ pot). The Opto inputs can be switches as shown in Figure 3-27 or logic signals from another device. The External Trip Opto Input at J1B-16 is active if connected as shown and the Level 2 PROTECTION block, EXTERNAL TRIP parameter is set to ON. Refer to Figure 3-27.

**Figure 3-27 Standard Run 3-Wire Mode Connection Diagram**

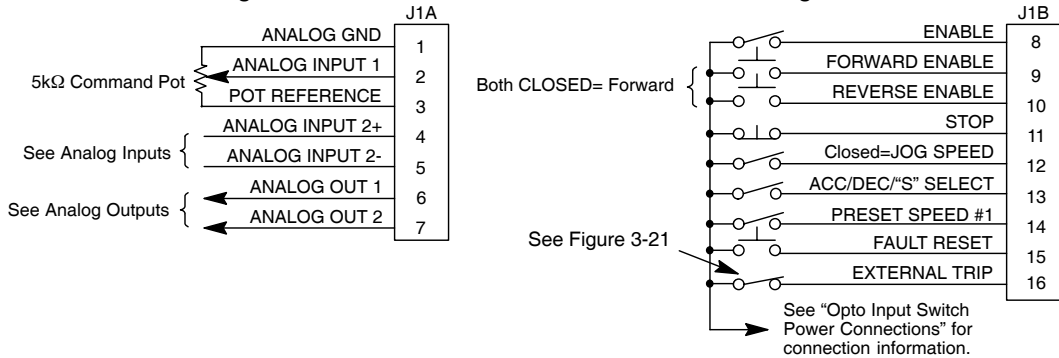

- J1B-8 CLOSED allows current to flow in the motor and produce torque.  
OPEN disables the control and motor coasts to a stop.
- J1B-9 Momentary CLOSED starts motor operation in the Forward direction. In JOG mode (J1B-12 CLOSED), continuous CLOSED jogs motor in the Forward direction.
- J1B-10 Momentary CLOSED starts motor operation in the Reverse direction. In JOG mode (J1B-12 CLOSED), CONTINUOUS closed JOGS motor in the Reverse direction.
- J1B-11 When OPEN motor decels to stop (depending on Keypad Stop mode).
- J1B-12 CLOSED places control in JOG mode, Forward and Reverse run are used to jog the motor.
- J1B-13 CLOSED selects ACC / DEC / S-CURVE group 2.  
OPEN selects group 1.
- J1B-14 CLOSED selects preset speed #1.  
OPEN selects Level 1 Input block, Command Select parameter.
- J1B-15 CLOSED to reset fault condition.  
OPEN to run.
- J1B-16 Optional External Trip input (not required). If used, you must set Level 2 Protection block, External Trip to "ON".  
OPEN causes an External Trip to be received by the control (when programmed to "ON"). When this occurs, the drive disables, drive "Ready" LED goes out and an external trip fault is displayed on the keypad display (also logged into the fault log).



**25M Operating Mode Configurations** Continued

**15 Speed 2-Wire Mode** In this mode, 15 preset motor speeds are stored during setup and selected during operation. Switch Truth Table is defined in Table 3-4.

Operation in the 15 Speed 2-Wire mode is controlled by the Opto Isolated inputs at J1B-11 through J1B-15. The Opto inputs can be switches as shown in Figure 3-28 or logic signals from another device. The External Trip Opto Input at J1B-16 is active if connected as shown and the Level 2 PROTECTION block, EXTERNAL TRIP parameter is set to ON.

Switched inputs at J1B-11 through J1B-14 allow selection of 15 preset speeds and provide Fault Reset as defined in Table 3-4.

**Figure 3-28 15 Speed 2-Wire Mode Connection Diagram**

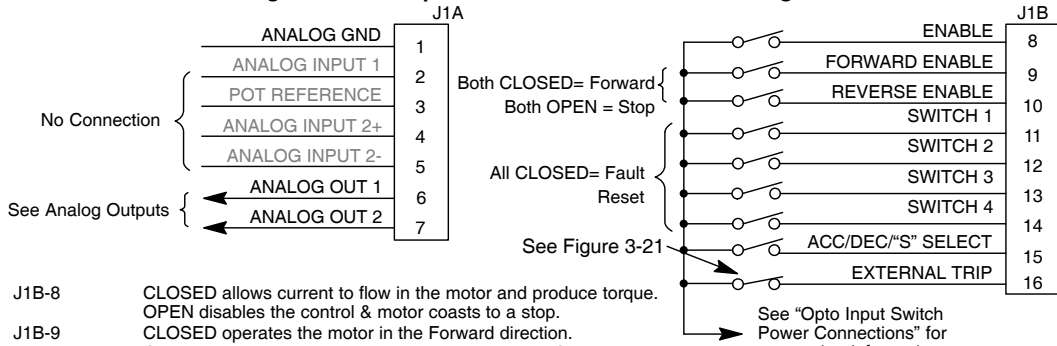

- J1B-8      CLOSED allows current to flow in the motor and produce torque. OPEN disables the control & motor coasts to a stop.
- J1B-9      CLOSED operates the motor in the Forward direction. OPEN motor decels to stop (depending on Keypad Stop mode).
- J1B-10     CLOSED operates motor in the Reverse direction. OPEN motor decels to stop (depending on Keypad Stop mode).
- J1B-11 to 14      Selects programmed preset speeds as defined in Table 3-4.
- J1B-15      CLOSED selects ACC / DEC / S-CURVE group 2. OPEN selects group 1.
- J1B-16      Optional External Trip input (not required). If used, you must set Level 2 Protection block, External Trip to "ON". OPEN causes an External Trip to be received by the control (when programmed to "ON"). When this occurs, the drive disables, drive "Ready" LED goes out and an external trip fault is displayed on the keypad display (also logged into the fault log).

**Table 3-4 Switch Truth Table for 15 Speed, 2 Wire Control Mode**

Function	J1B-11	J1B-12	J1B-13	J1B-14
Preset 1	Open	Open	Open	Open
Preset 2	Closed	Open	Open	Open
Preset 3	Open	Closed	Open	Open
Preset 4	Closed	Closed	Open	Open
Preset 5	Open	Open	Closed	Open
Preset 6	Closed	Open	Closed	Open
Preset 7	Open	Closed	Closed	Open
Preset 8	Closed	Closed	Closed	Open
Preset 9	Open	Open	Open	Closed
Preset 10	Closed	Open	Open	Closed
Preset 11	Open	Closed	Open	Closed
Preset 12	Closed	Closed	Open	Closed
Preset 13	Open	Open	Closed	Closed
Preset 14	Closed	Open	Closed	Closed
Preset 15	Open	Closed	Closed	Closed
Fault Reset	Closed	Closed	Closed	Closed

**25M Operating Mode Configurations** Continued

**3 SPD ANA 2 Wire Control Mode**

**Figure 3-29 3 SPD ANA 2 Wire Mode Connection Diagram**

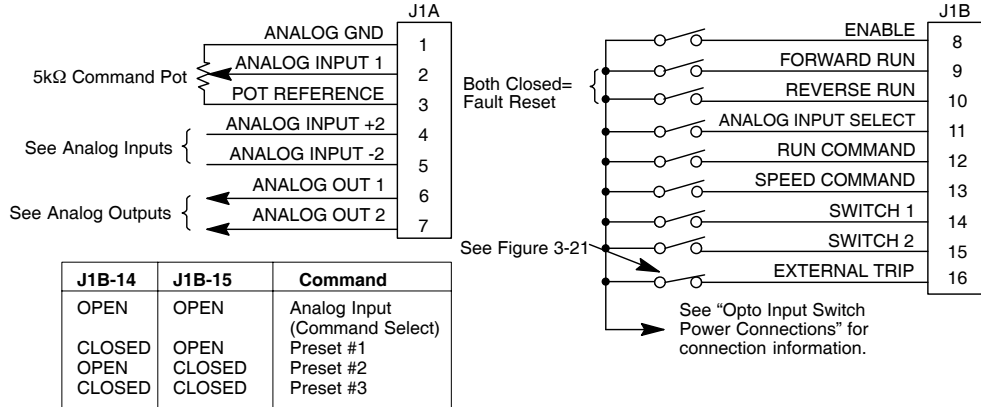

J1B-8 CLOSED allows current to flow in the motor and produce torque. OPEN disables the control & motor coasts to a stop.

J1B-9 CLOSED to start motor operation in the Forward direction. OPEN motor decels to stop (depending on Keypad Stop mode).

J1B-10 CLOSED to start motor operation in the Reverse direction. OPEN motor decels to stop (depending on Keypad Stop mode).

Note: Close both J1B-9 and J1B-10 to reset after a fault condition.

J1B-11 CLOSED selects Analog Input #1. OPEN selects the value of the Level 1 Input block, Command Select parameter.

Note: If Level 1 Input block, Command Select parameter is set to "Potentiometer", then Analog Input #1 is always selected.

J1B-12 CLOSED selects Start/Stop and Reset commands from the terminal strip. OPEN selects Start/Stop and Reset commands from keypad.

J1B-13 CLOSED selects the value of the Level 1 Input block, Command Select parameter. OPEN selects speed command from Keypad.

Note: When changing from terminal strip to keypad (J1B-12 or 13) the motor speed and direction will remain the same after the change.

J1B-14 Selects programmed preset speeds as defined in table shown in Figure 3-29.

J1B-15 Selects programmed preset speeds as defined in table shown in Figure 3-29.

Note: If J1B-14 and 15 are both open, the speed command input is selected (Analog Input #1 or 2).

J1B-16 Optional External Trip input (not required). If used, you must set Level 2 Protection block, External Trip to "ON". OPEN causes an External Trip to be received by the control (when programmed to "ON"). When this occurs, the drive disables, drive "Ready" LED goes out and an external trip fault is displayed on the keypad display (also logged into the fault log).

**25M Operating Mode Configurations** Continued

**3 SPD ANA 3 Wire Control Mode**

**Figure 3-30 3 SPD ANA 3 Wire Connection Diagram**

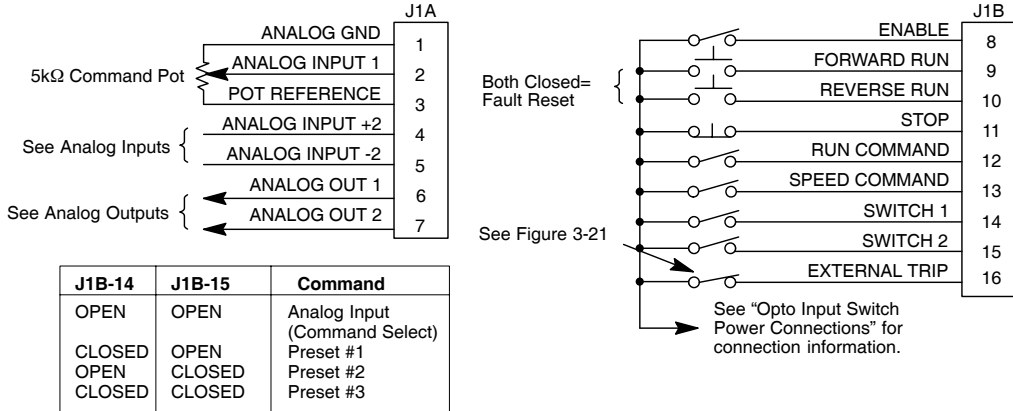

J1B-8 CLOSED allows current to flow in the motor and produce torque. OPEN disables the control & motor coasts to a stop.

J1B-9 Momentary CLOSED to start motor operation in the Forward direction. OPEN motor decels to stop (depending on Keypad Stop mode).

J1B-10 Momentary CLOSED to start motor operation in the Reverse direction. OPEN motor decels to stop (depending on Keypad Stop mode).

Note: Close both J1B-9 and J1B-10 to reset after a fault condition.

J1B-11 OPEN motor decels to stop (depending on Keypad Stop mode).

J1B-12 CLOSED selects Start/Stop and Reset commands from the terminal strip. OPEN selects Start/Stop and Reset commands from keypad.

J1B-13 CLOSED selects the value of the Level 1 Input block, Command Select parameter. OPEN selects speed command from Keypad.

Note: When changing from terminal strip to keypad (J1B-12 or 13) the motor speed and direction will remain the same after the change.

J1B-14 Selects programmed preset speeds as defined in table shown in Figure 3-30.

J1B-15 Selects programmed preset speeds as defined in table shown in Figure 3-30.

J1B-16 Optional External Trip input (not required). If used, you must set Level 2 Protection block, External Trip to "ON". OPEN causes an External Trip to be received by the control (when programmed to "ON"). When this occurs, the drive disables, drive "Ready" LED goes out and an external trip fault is displayed on the keypad display (also logged into the fault log).

**25M Operating Mode Configurations** Continued

**Bipolar Speed or Torque Control Mode with Multiple Parameter Sets**

**Figure 3-31 Bipolar Speed or Torque Mode Connection Diagram**

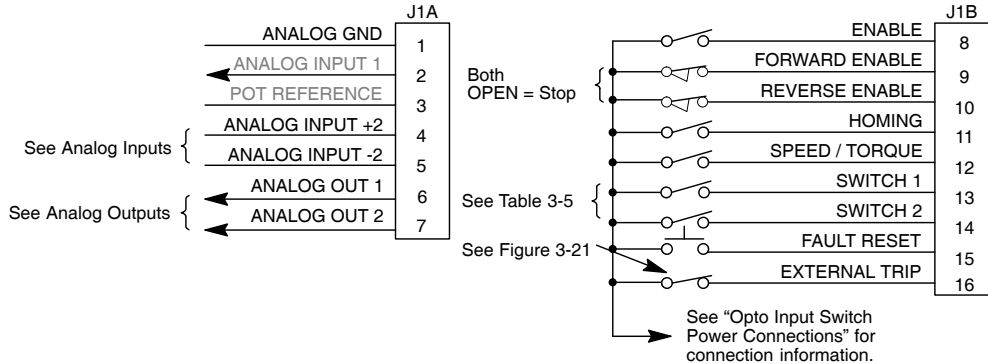

- J1B-8    CLOSED allows current to flow in the motor and produce torque.  
          OPEN disables the control & motor coasts to a stop.
- J1B-9    CLOSED to enable operation in the Forward direction.  
          OPEN motor decels to stop (depending on Keypad Stop mode). Drive will brake to a stop if Forward command still present).
- J1B-10    CLOSED to enable operation in the Reverse direction.  
          OPEN motor decels to stop (depending on Keypad Stop mode). Drive will brake to a stop if Reverse command still present).
- Note:    When J1B-9 and J1B-10 are both closed, Analog Input 2 is selected and the polarity of the input determines the direction of motor rotation.
- J1B-11    Causes the motor shaft to orient (Homing) to a marker or external switch.
- J1B-12    CLOSED puts the control in torque command mode.    OPEN puts the control in speed command mode.
- J1B-13 & 14    Select from four parameter tables as defined in Table 3-5.
- J1B-15    Momentary CLOSED to reset fault condition.  
          OPEN to run.
- J1B-16    Optional External Trip input (not required). If used, you must set Level 2 Protection block, External Trip to "ON".  
          OPEN causes an External Trip to be received by the control (when programmed to "ON"). When this occurs, the drive disables, drive "Ready" LED goes out and an external trip fault is displayed on the keypad display (also logged into the fault log).

**Table 3-5 Bipolar Mode Table Select Truth Table**

Function	J1B-13	J1B-14
Parameter Table #0	Open	Open
Parameter Table #1	Closed	Open
Parameter Table #2	Open	Closed
Parameter Table #3	Closed	Closed

---

## 25M Operating Mode Configurations Continued

### Multiple Parameter Sets

The following procedure allows you to program up to four complete sets of parameter values and to use these multiple parameter sets. When programming each parameter set, use the ENTER key to accept and automatically save parameter values.

Note: The control can be programmed in the REMOTE mode with the drive enabled. The control must be disabled to change the operating mode parameter and the operating mode can not be stored in a parameter table.

Note: Preset speed does not apply to table select.

1. If this is a new installation, do this procedure after the Pre-Operation Checklist and Power-Up Procedures at the end of this section.
2. Set the Level 1 INPUT block, Operating Mode parameter value to BIPOLAR in each of the parameter sets.
3. Set switches J1B-13 and J1B-14 to Parameter Table #0 (both switches open). Be sure switches J1B-9 and J1B-10 are OPEN, J1B-8 is CLOSED. Enter all parameter values, and autotune as instructed in Section 3 of this manual. This creates and saves the first parameter set which is numbered Table#0.
4. Set switches J1B-13 and J1B-14 to Parameter Table #1. Be sure switches J1B-9 and J1B-10 are OPEN, J1B-8 is CLOSED. Enter all parameter values, and autotune as instructed in Section 3 of this manual. This creates and saves the second parameter set which is numbered Table#1.
5. Set switches J1B-13 and J1B-14 to Parameter Table #2. Be sure switches J1B-9 and J1B-10 are OPEN, J1B-8 is CLOSED. Enter all parameter values, and autotune as instructed in Section 3 of this manual. This creates and saves the third parameter set which is numbered Table#2.
6. Set switches J1B-13 and J1B-14 to Parameter Table #3. Be sure switches J1B-9 and J1B-10 are OPEN, J1B-8 is CLOSED. Enter all parameter values, and autotune as instructed in Section 3 of this manual. This creates and saves the final parameter set which is numbered Table#3.
7. Remember that to change the value of a parameter in one of the parameter tables, you must first select the table using the switches. You cannot change a value in a table until you have first selected that table.

**25M Operating Mode Configurations** Continued

**Process Mode Connections**

**Figure 3-32 Process Mode Connection Diagram**

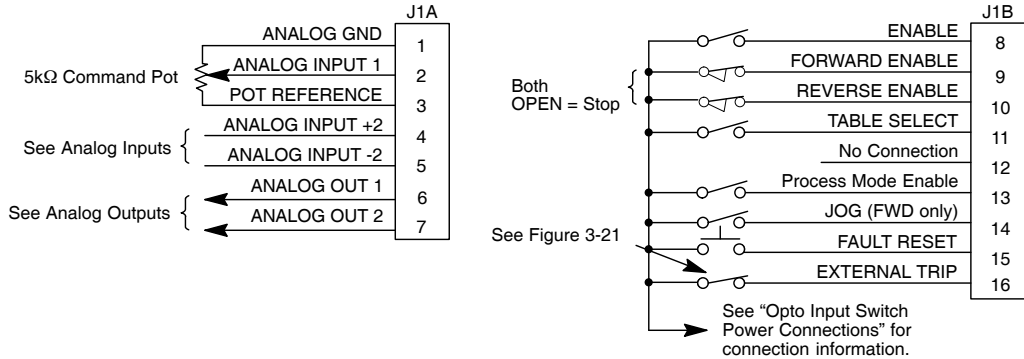

- J1B-8 CLOSED allows current to flow in the motor and produce torque. OPEN disables the control & motor coasts to a stop.
- J1B-9 CLOSED to enable operation in the Forward direction. OPEN motor decels to stop (depending on Keypad Stop mode).
- J1B-10 CLOSED to enable operation in the Reverse direction. OPEN motor decels to stop (depending on Keypad Stop mode).
- J1B-11 OPEN=Table 0, CLOSED=Table 1.
- J1B-13 CLOSED to enable the PID closed loop operation.
- J1B-14 CLOSED puts the control in JOG Mode. Control will only JOG in the forward direction. OPEN allows PID & Feedforward Speed or Torque control.
- J1B-15 Momentary CLOSED to reset fault condition. OPEN to run.
- J1B-16 Optional External Trip input (not required). If used, you must set Level 2 Protection block, External Trip to "ON". OPEN causes an External Trip to be received by the control (when programmed to "ON"). When this occurs, the drive disables, drive "Ready" LED goes out and an external trip fault is displayed on the keypad display (also logged into the fault log).

**Table 3-6 Process Mode Input Signal Compatibility**

Setpoint or Feedforward	Feedback					
	J1A-1 & 2	J1A-4 & 5	5V EXB <sup>①</sup>	10V EXB <sup>①</sup>	4-20mA EXB <sup>①</sup>	EXB Pulse FOL <sup>③</sup>
J1A-1 & 2						
J1A-4 & 5						
5V EXB <sup>①</sup>						
10V EXB <sup>①</sup>						
4-20mA EXB <sup>①</sup>						
EXB Pulse FOL <sup>③</sup>						
Serial <sup>①</sup> <sup>②</sup> <sup>③</sup>						

<sup>①</sup> Requires expansion board EXB103M01 (Serial + High Resolution Analog I/O for M Series controls).

<sup>②</sup> Requires expansion board EXB102M01 (Serial + Pulse Follower for M Series controls).

<sup>③</sup> Requires expansion board EXB101M01 (Serial Communications for M Series controls).

■

Conflicting inputs. Do not use same input signal multiple times.

Note: Only one expansion board may be installed.

**25M Operating Mode Configurations** Continued

**EPOT– 2 Wire Control Mode**

**Figure 3-33 EPOT– 2 Wire Mode Connection Diagram**

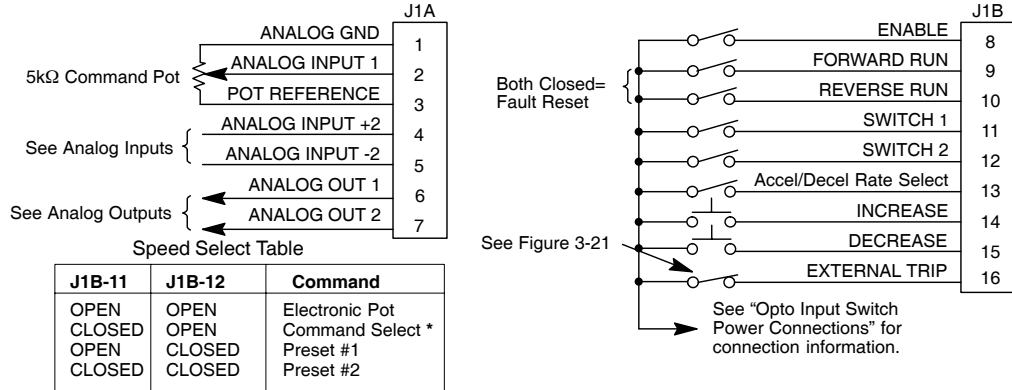

\* Command Select refers to the Level 1 Command Select parameter value.

J1B-8 CLOSED allows current to flow in the motor and produce torque. OPEN disables the control & motor coasts to a stop.

J1B-9 CLOSED operates the motor in the Forward direction. OPEN motor decels to stop (depending on Keypad Stop mode).

J1B-10 CLOSED operates motor in the Reverse direction. OPEN motor decels to stop (depending on Keypad Stop mode).

Note: Close both J1B-9 and J1B-10 to reset after a fault condition.

J1B-11 & 12 Selects programmed preset speeds as defined in Table of Figure 3-33.

J1B-13 CLOSED selects ACC / DEC / S-CURVE group 2. OPEN selects group 1.

J1B-14 Momentary CLOSED increases motor speed while contact is closed.

J1B-15 Momentary CLOSED decreases motor speed while contact is closed.

J1B-16 Optional External Trip input (not required). If used, you must set Level 2 Protection block, External Trip to "ON". OPEN causes an External Trip to be received by the control (when programmed to "ON"). When this occurs, the drive disables, drive "Ready" LED goes out and an external trip fault is displayed on the keypad display (also logged into the fault log).

## 25M Operating Mode Configurations Continued

### EPOT– 3 Wire Control Mode

**Figure 3-34 EPOT– 3 Wire Mode Connection Diagram**

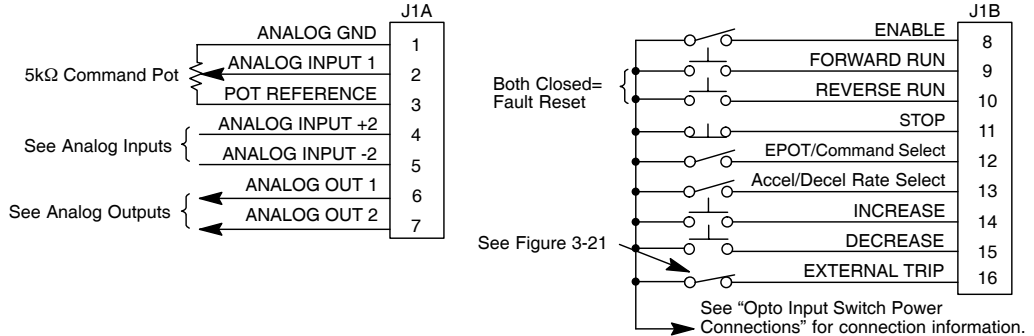

J1B-8 CLOSED allows current to flow in the motor and produce torque. OPEN disables the control & motor coasts to a stop.

J1B-9 Momentary CLOSED operates the motor in the Forward direction.

J1B-10 Momentary CLOSED operates motor in the Reverse direction.

Note: Close both J1B-9 and J1B-10 to reset after a fault condition.

J1B-11 Momentary OPEN motor decels to stop (depending on Keypad Stop mode).

J1B-12 OPEN selects EPOT.  
CLOSED selects Level 1 Command Select parameter value.

J1B-13 CLOSED selects ACC / DEC / S-CURVE group 2.  
OPEN selects group 1.

J1B-14 Momentary CLOSED increases motor speed while contact is closed.

J1B-15 Momentary CLOSED decreases motor speed while contact is closed.

J1B-16 Optional External Trip input (not required). If used, you must set Level 2 Protection block, External Trip to "ON". OPEN causes an External Trip to be received by the control (when programmed to "ON"). When this occurs, the drive disables, drive "Ready" LED goes out and an external trip fault is displayed on the keypad display (also logged into the fault log).

### Pre-Operation Checklist

This procedure will help get your drive up and running in the Keypad mode quickly. This will allow you to prove motor and control operation. You should understand the keypad programming & operation procedures described in Section 4 of this manual.

Note: The control terminal strip does not require any connections to operate in the Keypad mode (if Level 2 Protection block, External Trip parameter is set to OFF and Level 2 Protection block, Local INP Enable is set to "OFF").

1. Measure the AC line voltage and verify it matches the nameplate rating.
2. Inspect all power connections for accuracy, workmanship and tightness and compliance to codes.
3. Verify control and motor are grounded to each other and the control is connected to earth ground.
4. Check all signal wiring for accuracy.
5. Be certain all brake coils, contactors and relay coils have noise suppression. This should be an R-C filter for AC coils and reverse biased diodes for DC coils. MOV type transient suppression is not adequate.

### **Check of Motors and Couplings**

1. Verify motor shaft rotates freely.
2. Verify motor coupling is tight without backlash.
3. Verify holding brakes if any, are properly adjusted to fully release and set to the desired torque value.



---

## **Power-Up Procedure**

You should have an understanding of the keypad programming & operation procedures described in Section 4 of this manual.

### **Initial Conditions**

Be sure the PSM, DB resistor, Control, and Motor are wired according to the procedures described in this section.

1. Verify that any enable inputs to J1B-8 are open.
2. Connect the Keypad to J4 on the 25M panel.
2. Turn power on. Be sure there are no faults.
3. **(PSM-PR only)** Verify PSM "Ready" is ON and the "DB ON" and "Monitor" indicators are OFF. Verify the control "Ready" is ON.
4. **(25M-TR only)** Verify that "Ready" is ON and the "DB" is OFF.
5. Set the Level 1 Input block, Operating Mode to "KEYPAD".
6. Be sure the Level 2 Protection block, Local Enable INP parameter is OFF and the Level 2 Protection block, External Trip parameter is OFF.
7. Enter the following motor data in the Level 2 Motor Data block parameters:  
Motor Voltage (input)  
Motor Rated Amps (FLA)  
Motor Rated Speed (base speed)  
Motor Rated Frequency  
Motor Mag Amps (no load current)  
Encoder Counts
8. At the Level 2 Motor Data block, go to CALC Presets and select YES (using the ▲ key). Press ENTER and let the control calculate the preset values for the parameters that are necessary for control operation.
9. Disconnect the motor from the load (including coupling or inertia wheels). If the load cannot be disconnected, refer to Section 6 and manually tune the control. After manual tuning, perform steps 15 through 19.

**⚠ WARNING: The motor shaft will rotate during the autotune procedure. Be certain that unexpected motor shaft movement will not cause injury to personnel or damage to equipment.**

10. Go to Level 2 Autotune block, and do the following tests:  
CMD OFFSET TRIM  
CUR LOOP COMP  
STATOR R1  
FLUX CUR SETTING  
FEEDBACK TESTS  
SLIP FREQ TEST
11. Remove all power from the control.
12. Couple the motor to its load.
13. Turn power on. Be sure no errors are displayed.
14. Set the Level 2 Output Limits block, "MIN OUTPUT SPEED" parameter.
15. Set the Level 2 Output Limits block, "MAX OUTPUT SPEED" parameter.
16. Go to Level 2 Autotune block, and perform the SPD CNTRLR CALC test.
17. Run the drive from the keypad using one of the following: the arrow keys for direct speed control, keypad entered speed or the JOG mode.
18. Select and program additional parameters to suit your application.

The control is now ready for use in the Keypad mode. If a different operating mode is desired, refer to Section 3 Control Connections and Section 4 Programming and Operation.

## Section 4 Programming and Operation

### Overview

The keypad is used to program the control parameters; to operate the motor when programmed for the Keypad operating mode; and to monitor the status and outputs of the control by accessing the display options, the diagnostic menus and the fault log.

**Figure 4-1 Keypad**

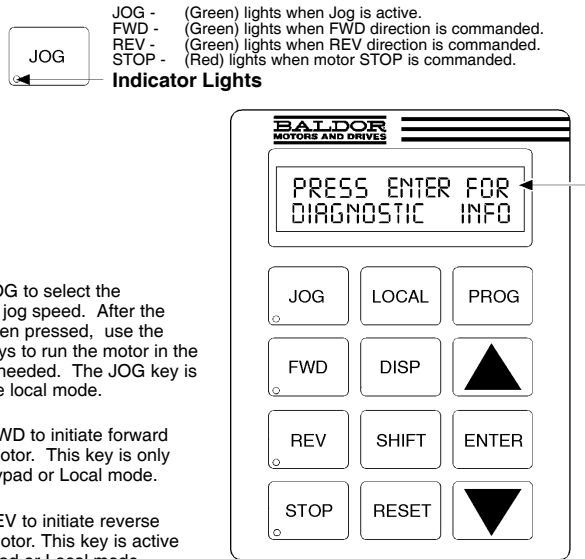

**JOG** - Press JOG to select the preprogrammed jog speed. After the JOG key has been pressed, use the FWD or REV keys to run the motor in the direction that is needed. The JOG key is only active in the local mode.

**FWD** - Press FWD to initiate forward rotation of the motor. This key is only active in the Keypad or Local mode.

**REV** - Press REV to initiate reverse rotation of the motor. This key is active only in the Keypad or Local mode.

**STOP** - Press STOP to initiate a stop sequence. Depending on the setup of the control, the motor will either ramp or coast to a stop. This key is operational in all modes of operation unless it has been disabled by the Keypad Stop parameter in the Keypad (programming) Setup Block.

**Note:** If the control is operating in remote mode and the stop key is pressed the control will change to the local mode when the stop command is initiated. To resume operation in the remote mode, press the LOCAL key.

**LOCAL** - Press LOCAL to change between the Local (keypad) and Remote operation. When the control is in the Local mode all other external commands to the J1B terminal strip will be ignored with the exception of the external trip input.

**DISP** - Press DISP to return to Display mode from Programming mode. Provides operational status and advances to the next display menu item.

**SHIFT** - Press SHIFT in the program mode to control cursor movement. Pressing the SHIFT key once moves the blinking cursor one character position to the right. While in Program mode, a parameter value may be reset to the factory preset value by pressing the SHIFT key until the arrow symbols at the far left of the keypad display are flashing, then press an arrow key. In the Display mode the SHIFT key is used to adjust the keypad contrast.

**RESET** - Press RESET to clear all fault messages (in local mode). Can also be used to return to the top of the block programming menu without saving any parameter value changes.

**Keypad Display** - Displays status information during Local or Remote operation. It also displays information during parameter setup and fault or Diagnostic Information.

**PROG** - Press PROG to enter the program mode. While in the Program mode the PROG key is used to edit a parameter setting.

#### ▲ - (UP Arrow)

Press ▲ to change the value of the parameter being displayed. Pressing ▲ increments the value to the next greater value. Also, when the fault log or parameter list is displayed, the ▲ key will scroll upward through the list. In the local mode pressing the ▲ key will increase motor speed to the next greater value.

**ENTER** - Press ENTER to save parameter value changes and move back to the previous level in the programming menu. In the Display mode the ENTER key is used to directly set the local speed reference. It is also used to select other operations when prompted by the keypad display.

#### ▼ - (Down Arrow)

Press ▼ to change the value of the parameter being displayed. Pressing ▼ decrements the value to the next lesser value. Also, when the fault log or parameter list is displayed, the ▼ key will scroll downward through the list. In the local mode pressing the ▼ key will decrease motor speed to the next lower value.

## Display Mode



During normal operation, the control is in the DISPLAY MODE. In this mode, the Keypad Display shows the status of the control as in the following example.



The DISPLAY MODE is used to view operating conditions, DIAGNOSTIC INFO and the FAULT LOG and to adjust the Display Contrast. The description of how to do these tasks are described on the following pages.

**Adjusting Display Contrast** When AC power is applied to the control the keypad should display the status of the control. At power up, the display may be blank if the contrast is improperly set. Use the following procedure to adjust the display contrast.

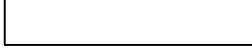
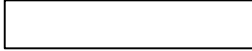
(Contrast may be adjusted in display mode when motor is stopped or running)

Action	Description	Display	Comments
Apply Power	No visible display		
Press DISP Key	Places control in display mode		Display mode with nothing visible (blank) or too dim to be read.
Press SHIFT SHIFT	Allows display contrast adjustment		
Press ▲ or ▼ Key	Adjusts display intensity		
Press ENTER	Saves level of contrast and exits to display mode		Typical display

**Display Mode** Continued

**Display Screens & Diagnostic Information Access**

Action	Description	Display	Comments
Apply Power		BALDOR MOTORS & DRIVES	Logo display for 5 seconds.
	Display mode showing motor speed.	STOP MOTOR SPEED LOCAL 0 RPM	No faults present. Local keypad mode. If in remote/serial mode, press local for this display.
Press DISP key	Display showing motor frequency.	STOP FREQUENCY LOCAL 0.00 HZ	
Press DISP key	Scroll to diagnostic info block.	PRESS ENTER FOR DIAGNOSTIC INFO	
Press ENTER key	Access diagnostic information.	STOP SPEED REF LOCAL 0 RPM	Displays commanded speed, direction of rotation, Local/Remote.
Press DISP key	Display mode showing control temperature.	STOP CONTROL TEMP LOCAL 0.0°C	Displays operating temperature in degrees C.
Press DISP key	Display mode showing bus voltage.	STOP BUS VOLTAGE LOCAL 321V	
Press DISP key	Display mode showing % overload current remaining.	STOP OVRLD LEFT LOCAL 100.00%	
Press DISP key	Display mode showing real time opto inputs & outputs states. 0=Open, 1=Closed.	DIGITAL I/O 000000000 0000	Opto Inputs states (Left); opto outputs states (Right).
Press DISP key	Display mode showing time the drive has been powered up.	TIME FROM PWR UP 0000000.01.43	HR.MIN.SEC format.
Press DISP key	Display mode showing continuous amps; PK amps rating; amps/volt scale of feedback, power base ID.	X.XA X.X APK X.XX A/V 10.XXX	
Press DISP key	Display mode showing which Group1 or 2 expansion boards are installed and recognized.	G1 NOT INSTALLED G2 NOT INSTALLED	In this case, no expansion boards are installed.
Press DISP key	Display mode showing motor shaft revolutions from the REV home set point.	POSITION COUNTER + 000.00000 REV	
Press DISP key	Display mode showing parameter table selected.	STOP TABLE LOCAL 0	
Press DISP key	Display mode showing software version and revision installed in the control.	SOFTWARE VERSION XXX.X.XX	
Press DISP key	Displays exit choice.	PRESS ENTER FOR DIAGNOSTIC EXIT	Press ENTER to exit diagnostic information.

**Display Mode** Continued

**Fault Log Access**

When a fault condition occurs, motor operation stops and a fault code is displayed on the Keypad display. The control keeps a log of up to the last 31 faults. If more than 31 faults have occurred, the oldest fault will be deleted from the fault log to make room for the newest fault. To access the fault log perform the following procedure:

Action	Description	Display	Comments
Apply Power		BALDOR MOTORS & DRIVES	Logo display for 5 seconds.
	Display mode showing motor speed.	STOP MOTOR SPEED LOCAL 0 RPM	Display mode.
Press DISP key	Press DISP to scroll to the Fault Log entry point.	PRESS ENTER FOR FAULT LOG	
Press ENTER key	Display first fault type and time fault occurred.	EXTERNAL TRIP 1: 0:00:30	1 = Most recent fault. 2 = Next most recent fault. ETC.
Press ▲ key	Scroll through fault messages.	PRESS ENTER FOR FAULT LOG EXIT	If no messages, the fault log exit choice is displayed.
Press ENTER key	Return to display mode.	STOP MOTOR SPEED LOCAL 0 RPM	Display mode stop key LED is on.

## Program Mode

The Program Mode is used to enter or change parameter values, enter or change motor data, and autotune the drive.

From the Display Mode press the PROG key to access the Program Mode.

Note: When a parameter is selected, alternately pressing the Disp and Prog keys will change between the Display Mode and the selected parameter. When a parameter is selected for programming, the keypad display provides the following information:



**Parameter Status.** All programmable parameters are displayed with a "P:" in the lower left corner of the keypad display. If a parameter is displayed with a "V:", the parameter value may be viewed but not changed while control is enabled. If the parameter is displayed with an "L:", the value is locked and the security access code must be entered before its' value can be changed.

## Parameter Blocks Access for Programming

Use the following procedure to access parameter blocks to program the control.

Action	Description	Display	Comments
Apply Power	Keypad Display shows this opening message.  If no faults and programmed for LOCAL operation.  If no faults and programmed for REMOTE operation.  If fault is displayed, refer to the Troubleshooting section of this manual.	<pre>BALDOR MOTORS &amp; DRIVES  STOP MOTOR SPEED LOCAL 0 RPM  STOP MOTOR SPEED REMOTE 0 RPM</pre>	Logo display for 5 seconds.  Display mode.  Display mode.
Press PROG key		<pre>PRESS ENTER FOR PRESET SPEEDS</pre>	Press ENTER to access Preset Speed parameters.
Press ▲ or ▼ key	Scroll to the ACCEL/DECEL block.	<pre>PRESS ENTER FOR ACCEL/DECEL RATE</pre>	Press ENTER to access Accel and Decel rate parameters.
Press ▲ or ▼ key	Scroll to the Level 2 Block.	<pre>PRESS ENTER FOR LEVEL 2 BLOCKS</pre>	Press ENTER to access Level 2 Blocks.
Press ENTER key	First Level 2 block display.	<pre>PRESS ENTER FOR OUTPUT LIMITS</pre>	
Press ▲ or ▼ key	Scroll to Programming Exit menu.	<pre>PRESS ENTER FOR PROGRAMMING EXIT</pre>	Press ENTER to return to Display mode.
Press ENTER key	Return to display mode.	<pre>STOP MOTOR SPEED LOCAL 0 RPM</pre>	

**Program Mode** Continued

**Changing Parameter Values when Security Code Not Used**

Use the following procedure to program or change a parameter already programmed into the control when a security code is not being used.

The example shown changes the operating mode from Keypad to Bipolar.

Action	Description	Display	Comments
Apply Power	Keypad Display shows this opening message.	<pre>BALDOR MOTORS &amp; DRIVES</pre>	Logo display for 5 seconds.
	If no faults and programmed for LOCAL operation.	<pre>STOP MOTOR SPEED LOCAL          0 RPM</pre>	Display mode. Stop LED on.
Press PROG key	Access programming mode.	<pre>PRESS ENTER FOR PRESET  SPEEDS</pre>	
Press ▲ or ▼ key	Scroll to Level 1 Input Block. Then press ENTER to access Input Block.	<pre>PRESS ENTER FOR INPUT</pre>	Press ENTER to access INPUT block parameter.
Press PROG key	Access Operating Mode.	<pre>OPERATING  MODE P:          KEYPAD</pre>	Keypad mode shown is the factory setting.
Press ▲ key	Scroll to make your selection.	<pre>OPERATING  MODE P:          BIPOLAR</pre>	Typical selection.
Press ENTER or PROG	Save selection to memory.	<pre>OPERATING  MODE P:          BIPOLAR</pre>	
Press ▲ key	Scroll to menu exit.	<pre>PRESS ENTER FOR MENU EXIT</pre>	
Press ENTER key	Return to Input Block.	<pre>PRESS ENTER FOR INPUT</pre>	
Press DISP key	Return to Display Mode.	<pre>STOP MOTOR SPEED LOCAL          0 RPM</pre>	Typical display mode.

**Program Mode** Continued

**Reset Parameters to Factory Settings**

Sometimes it is necessary to restore the parameter values to the factory settings. Follow this procedure to do so.

Note: All parameter values already programmed will be changed when resetting the control to factory settings.

Note: After factory settings are restored, motor data must be programmed and the drive must be autotuned.

Action	Description	Display	Comments
Apply Power	Keypad Display shows this opening message.	<pre>BALDOR MOTORS &amp; DRIVES</pre>	Logo display for 5 seconds.
	If no faults and programmed for LOCAL operation.	<pre>STOP MOTOR SPEED LOCAL          0 RPM</pre>	Display mode. Stop LED on.
Press PROG key	Enter program mode.	<pre>PRESS ENTER FOR PRESET     SPEEDS</pre>	
Press ▲ or ▼ key	Scroll to Level 2 Blocks.	<pre>PRESS ENTER FOR LEVEL 2   BLOCKS</pre>	
Press ENTER key	Select Level 2 Blocks.	<pre>PRESS ENTER FOR OUTPUT LIMITS</pre>	
Press ▲ or ▼ key	Scroll to the Miscellaneous block.	<pre>PRESS ENTER FOR MISCELLANEOUS</pre>	
Press ENTER key	Select Miscellaneous block.	<pre>RESTART AUTO/MAN P:          MANUAL</pre>	
Press ▲ key	Scroll to Factory Settings parameter.	<pre>FACTORY SETTINGS P:          NO</pre>	
Press ENTER key	Access Factory Settings parameter.	<pre>FACTORY SETTINGS <math>\Delta</math> <input type="checkbox"/> NO</pre>	<input type="checkbox"/> represents blinking cursor.
Press ▲ key	Scroll to YES, to choose original factory settings.	<pre>FACTORY SETTINGS <math>\Delta</math> <input type="checkbox"/> YES</pre>	
Press ENTER key	Restores factory settings.	<pre>FACTORY SETTINGS P:LOADING PRESETS</pre>	"Loading Presets" is first message "Operation Done" is next "No" is displayed last.
Press ▲ key	Scroll to menu exit.	<pre>PRESS ENTER FOR MENU EXIT</pre>	
Press ENTER key	Return to display mode.	<pre>STOP MOTOR SPEED LOCAL          0 RPM</pre>	Display mode. Stop LED on.



**Program Mode** Continued

**Initialize New Software** When new software is installed, the control must be initialized to the new software version and memory locations. Use the following procedure to initialize the software.

Note: All parameter values already programmed will be changed when resetting the control to factory settings.

Note: After factory settings are restored, motor data must be programmed and the drive must be autotuned.

Action	Description	Display	Comments
Apply Power	Keypad Display shows this opening message.	<pre>BALDOR MOTORS &amp; DRIVES</pre>	Logo display for 5 seconds.
	If no faults and programmed for LOCAL operation.	<pre>STOP MOTOR SPEED LOCAL          0 RPM</pre>	Display mode. Stop LED on.
Press PROG key	Enter program mode.	<pre>PRESS ENTER FOR PRESET   SPEEDS</pre>	
Press ▲ or ▼ key	Scroll to Level 2 Blocks.	<pre>PRESS ENTER FOR LEVEL 2   BLOCKS</pre>	
Press ENTER key	Select Level 2 Blocks.	<pre>PRESS ENTER FOR OUTPUT LIMITS</pre>	
Press ▲ or ▼ key	Scroll to the Miscellaneous block.	<pre>PRESS ENTER FOR MISCELLANEOUS</pre>	
Press ENTER key	Select Miscellaneous block.	<pre>RESTART AUTO/MAN P:          MANUAL</pre>	
Press ▲ key	Scroll to Factory Settings parameter.	<pre>FACTORY SETTINGS P:          NO</pre>	
Press ENTER key	Access Factory Settings parameter.	<pre>FACTORY SETTINGS <math>\updownarrow</math> <input type="checkbox"/> NO</pre>	<input type="checkbox"/> represents blinking cursor.
Press ▲ key	Scroll to YES, to choose original factory settings.	<pre>FACTORY SETTINGS <math>\updownarrow</math> <input type="checkbox"/> YES</pre>	
Press ENTER key	Restores factory settings.	<pre>FACTORY SETTINGS P:LOADING PRESETS</pre>	"Loading Presets" is first message "Operation Done" is next "No" is displayed last.
Press ▲ key	Scroll to menu exit.	<pre>PRESS ENTER FOR MENU EXIT</pre>	
Press ENTER key	Return to display mode.	<pre>STOP MOTOR SPEED LOCAL          0 RPM</pre>	Display mode. Stop LED on.
Press ▲ key	Scroll to diagnostic info block.	<pre>PRESS ENTER FOR DIAGNOSTIC INFO</pre>	
Press ENTER key	Access diagnostic information.	<pre>STOP SPEED   REF LOCAL        0 RPM</pre>	Displays commanded speed, direction of rotation, Local/ Remote and motor speed.
Press DISP key	Display mode showing software version and revision installed in the control.	<pre>SOFTWARE VERSION XXX-X.XX</pre>	Verify new software version.
Press DISP key	Displays exit choice.	<pre>PRESS ENTER FOR DIAGNOSTIC EXIT</pre>	Press ENTER to exit diagnostic information.

## Operation Examples

### Operating the Control from the Keypad

If the control is configured for remote or serial control, the LOCAL Mode must be activated before the control may be operated from the keypad. To activate the LOCAL Mode, first the motor must be stopped using the keypad STOP key (if enabled), remote commands or serial commands.

Note: Pressing the keypad STOP key (if enabled) will automatically issue a motor stop command and change to LOCAL mode.

When the motor has stopped, the LOCAL Mode is activated by pressing the "LOCAL" key. Selection of the LOCAL Mode overrides any remote or serial control inputs except for the External Trip input, Local Enable Input or STOP input.

The control can operate the motor in three (3) different ways from the keypad.

1. JOG Command.
2. Speed adjustment with Keypad entered values.
3. Speed adjustment using the Keypad arrow keys.

Note: If the control has been configured for Keypad in the operating mode parameter (level 1, input block), then no other means of operation is permitted other than from the keypad.

### Accessing the Keypad JOG Command

Action	Description	Display	Comments
Apply Power	Keypad Display shows this opening message.	<pre>BALDOR MOTORS &amp; DRIVES</pre>	Logo display for 5 seconds.
	If no faults and programmed for LOCAL operation.	<pre>STOP MOTOR SPEED LOCAL      0 RPM</pre>	Display mode. Stop LED on.
Press JOG key	Access programmed JOG speed.	<pre>STOP MOTOR SPEED LOCAL      0 RPM</pre>	JOG key LED on.
Press and hold FWD or REV key	Move control forward or reverse at JOG speed.	<pre>FWD MOTOR SPEED LOCAL     200 RPM</pre>	Control runs while FWD or REV key is pressed. JOG & FWD (or REV) LED's on.
Press JOG key	Disables JOG mode.	<pre>STOP MOTOR SPEED LOCAL      0 RPM</pre>	JOG LED off. Stop key LED on.

## Speed Adjustment using the Keypad

Action	Description	Display	Comments
Apply Power	Keypad Display shows this opening message.	<pre>BALDOR MOTORS &amp; DRIVES</pre>	Logo display for 5 seconds.
	If no faults and programmed for LOCAL operation.	<pre>STOP MOTOR SPEED LOCAL 0 RPM</pre>	Display mode. Stop LED on.
Press ENTER key	Select the local speed reference.	<pre>MOTOR SPEED 00000 0 RPM</pre>	
Press SHIFT key	Move blinking cursor right one digit.	<pre>MOTOR SPEED 00000 0 RPM</pre>	□ represents blinking cursor.
Press ▲ key	Increase thousands value by one digit.	<pre>MOTOR SPEED 01000 0 RPM</pre>	
Press ENTER key	Save new value and return to display mode.	<pre>STOP MOTOR SPEED LOCAL 0 RPM</pre>	
Press FWD or REV key	Motor runs FWD or REV at commanded speed.	<pre>FWD MOTOR SPEED LOCAL 1000 RPM</pre>	FWD (REV) LED on.
Press STOP key	Motor stop command issued.	<pre>STOP MOTOR SPEED LOCAL 0 RPM</pre>	Display mode. Stop LED on.

## Speed Adjustment Using Arrow Keys

Action	Description	Display	Comments
Apply Power	Keypad Display shows this opening message.	<pre>BALDOR MOTORS &amp; DRIVES</pre>	Logo display for 5 seconds.
	If no faults and programmed for LOCAL operation.	<pre>STOP MOTOR SPEED LOCAL 0 RPM</pre>	Display mode. Stop LED on.
Press FWD or REV key	Motor runs FWD or REV at selected speed.	<pre>FWD MOTOR SPEED LOCAL 0 RPM</pre>	FWD key LED on.
Press ▲ key	Increase motor speed.	<pre>FWD MOTOR SPEED LOCAL 500 RPM</pre>	Display mode.
Press ▼ key	Decrease motor speed.	<pre>FWD MOTOR SPEED LOCAL 200 RPM</pre>	Display mode.
Press STOP key	Motor stop command issued.	<pre>STOP MOTOR SPEED LOCAL 0 RPM</pre>	Display mode. Stop LED on.
Press FWD or REV key	Motor runs FWD or REV at commanded speed.	<pre>FWD MOTOR SPEED LOCAL 200 RPM</pre>	Motor runs at previously set speed.
Press STOP key	Motor stop command issued.	<pre>STOP MOTOR SPEED LOCAL 0 RPM</pre>	Display mode. Stop LED on.

## Security System Changes

Access to programmed parameters can be protected from change by the security code feature. The Security Code is defined by setting the Level 2 Security Control block. To implement the security feature, use the following procedure:

Action	Description	Display	Comments
Apply Power	Keypad Display shows this opening message.		Logo display for 5 seconds.
	If no faults and programmed for LOCAL operation.		Display mode. Stop LED on.
Press PROG key	Enter program mode.		
Press ▲ or ▼ key	Scroll to Level 2 Blocks.		
Press ENTER key	Access Level 2 Blocks.		
Press ▲ or ▼ key	Scroll to the Security Control block.		
Press ENTER key	Access the Security Control block.		
Press ▲ key	Scroll to the Access Code parameter.		
Press ENTER key	The Access Code parameter can be changed.		<input type="checkbox"/> represents blinking cursor.
Press ▼ key	Use ▼ key to change value. Example: 8999.		<input type="checkbox"/> represents blinking cursor.
Press ENTER key	Save Access Code parameter		Keypad Display will not show user access code. Record its' value for future reference.
Press ▼ key	Scroll to Security State.		
Press ENTER key	Access Security State parameter.		<input type="checkbox"/> represents blinking cursor.
Press ▲ key	Select Local Security.		
Press ENTER key	Save selection.		P: will change to L: after returning to display mode for longer than time set in Access Time parameter.
Press DISP key	Return to Display mode.		Typical display mode.

Note: Please record your access code and store it in a safe place. If you cannot gain entry into parameter values to change a protected parameter, please contact Baldor. Be prepared to give the 5 digit code located on the lower right side of the Keypad Display at the Enter Code parameter prompt.

## Changing Parameter Values with a Security Code in Use

Action	Description	Display	Comments
Apply Power	Keypad Display shows this opening message.	BALDOR MOTORS & DRIVES	Logo display for 5 seconds.
	If no faults and programmed for LOCAL operation.	STP 0V 0 RPM LOC 0.0 A 0.0 HZ	Display mode. Stop LED on.
Press PROG key	Enter program mode.	PRESS ENTER FOR PRESET SPEEDS	
Press ▲ or ▼ key	Scroll to Input block.	PRESS ENTER FOR INPUT	
Press ENTER key	Access Input block to change Operating Mode setting.	OPERATING MODE L: KEYPAD	L: shows parameter is Locked.
Press ENTER key	When security on, parameter values cannot be changed.	.. ENTER CODE .. ⏏ 9999 23956	
Press ▼ key	Enter the Access Code . Example: 8999.	.. ENTER CODE .. ⏏ 8999 23956	<input type="checkbox"/> represents blinking cursor.
Press ENTER key		OPERATING MODE ⏏ KEYPAD	
Press ▲ or ▼ key	Scroll to make your selection.	OPERATING MODE ⏏ STANDARD RUN	
Press ENTER	Save selected parameter	OPERATING MODE P: STANDARD RUN	P: will change to L: after you return to Display mode for longer than the time specified in the Access Time parameter.
Press ▲ or ▼ key	Scroll to Menu Exit.	PRESS ENTER FOR MENU EXIT	
Press ENTER key	Returns to Input block.	PRESS ENTER FOR INPUT	
Press DISP key	Return to Display mode.	STP 0V 0 RPM LOC 0.0 A 0.0 HZ	Typical display mode.

Note: Please record your access code and store it in a safe place. If you cannot gain entry into parameter values to change a protected parameter, please contact Baldor. Be prepared to give the 5 digit code located on the lower right side of the Keypad Display at the Enter Code prompt.

## Security System Access Timeout Parameter Change

Action	Description	Display	Comments
Apply Power	Keypad Display shows this opening message.	<pre>BALDOR MOTORS &amp; DRIVES</pre>	Logo display for 5 seconds.
	If no faults and programmed for LOCAL operation.	<pre>STP 0V 0 RPM LOC 0.0 A 0.0 HZ</pre>	Display mode. Stop LED on.
Press PROG key	Enter program mode.	<pre>PRESS ENTER FOR PRESET SPEEDS</pre>	
Press ▲ or ▼ key	Scroll to Level 2 Blocks.	<pre>PRESS ENTER FOR LEVEL 2 BLOCKS</pre>	
Press ENTER key	Access Level 2 Blocks.	<pre>PRESS ENTER FOR OUTPUT LIMITS</pre>	
Press ▲ or ▼ key	Scroll to the Security Control block.	<pre>PRESS ENTER FOR SECURITY CONTROL</pre>	
Press ENTER key	Access the Local Security block.	<pre>SECURITY STATE L:LOCAL SECURITY</pre>	
Press ▲ key	Scroll to the Access Timeout parameter.	<pre>ACCESS TIMEOUT L: 0 SEC</pre>	
Press ENTER key	Attempt to access the Access Timeout parameter.	<pre>.. ENTER CODE .. 9999 23956</pre>	<input type="checkbox"/> represents blinking cursor.
Press ▼ key	Use ▼ key to change value. Example: 8999.	<pre>.. ENTER CODE .. 0999 23956</pre>	Note: Ignore the 5 digit number to the right (example: 23956).
Press ENTER key	Save Access Code parameter	<pre>ACCESS TIMEOUT 000 0 S</pre>	Security code entered is correct. All parameters may be changed.
Press SHIFT key.	Move cursor right on digit.	<pre>ACCESS TIMEOUT 0 0 0 0 S</pre>	Access Timeout can be any value between 0 and 600 seconds.
Press ▲ key 3 times	Change the 0 to 3.	<pre>ACCESS TIMEOUT 0 3 0 0 SEC</pre>	Example: 30 seconds.
Press ENTER key	Save value.	<pre>ACCESS TIMEOUT P: 30 S</pre>	P: will change to L: after you return to Display mode for longer than the time specified in the Access Time parameter.
Press DISP key	Return to Display mode.	<pre>STP 0V 0 RPM LOC 0.0 A 0.0 HZ</pre>	Typical display mode.

Note: Please record your access code and store it in a safe place. If you cannot gain entry into parameter values to change a protected parameter, please contact Baldor. Be prepared to give the 5 digit code located on the lower right side of the Keypad Display at the Enter Code prompt.

## Parameter Adjustments

To make programming easier, parameters have been arranged into the two level structure shown in Table 4-1. Press the PROG key to enter the programming mode. The first programming block to be displayed is "Preset Speeds". Use the Up (▲) and Down (▼) arrows to scroll through the parameter blocks. Press ENTER to access parameters within a programing block.

Tables 4-2 and 4-3 provide an explanation of each parameter. A complete Parameter Block Values list is located at the end of this manual. This list defines the programmable range and factory preset value for each parameter. The list has a space to record your settings for future reference.

**Table 4-1 List of Parameters** (Version 1.06)

LEVEL 1 BLOCKS	LEVEL 1 BLOCKS	LEVEL 2 BLOCKS	
<b>Preset Speeds</b>	<b>Input</b>	<b>Output Limits</b>	<b>Brake Adjust</b> (25M-PO only)
Preset Speed #1	Operating Mode	Min Output Speed	DC Brake Current
Preset Speed #2	Command Select	Max Output Speed	
Preset Speed #3	ANA CMD Inverse	PK Current Limit	<b>Process Control</b>
Preset Speed #4	ANA CMD Offset	PWM Frequency	Process Feedback
Preset Speed #5	ANA 2 Deadband	CUR Rate Limit	Process Inverse
Preset Speed #6	ANA 1 CUR Limit		Setpoint Source
Preset Speed #7		<b>Custom Units</b>	Setpoint Command
Preset Speed #8	<b>Output</b>	Decimal Places	Set PT ADJ Limit
Preset Speed #9	Opto Output #1	Value at Speed	Process ERR TOL
Preset Speed #10	Opto Output #2	Units of Measure	Process PROP Gain
Preset Speed #11	Opto Output #3		Process INT Gain
Preset Speed #12	Opto Output #4	<b>Protection</b>	Process DIFF Gain
Preset Speed #13	Zero SPD Set PT	Overload	Follow I:O Ratio
Preset Speed #14	At Speed Band	External Trip	Follow I:O Out
Preset Speed #15	Set Speed	Local Enable INP	Master Encoder
	Analog Out #1	Following Error	
<b>Accel / Decel Rate</b>	Analog Out #2	Torque Proving	<b>Communications</b>
Accel Time #1	Analog #1 Scale		Protocol
Decel Time #1	Analog #2 Scale	<b>Miscellaneous</b>	Baud Rate
S-Curve #1	ANA Out Offset	Restart Auto/Man	Drive Address
Accel Time #2	Position Band	Restart Fault/Hr	
Decel Time #2		Restart Delay	<b>Auto-Tuning</b>
S-Curve #2	<b>Vector Control</b>	Factory Settings	CALC Presets
	CTRL Base Speed	Homing Speed	CMD Offset Trim
<b>Jog Settings</b>	Current PROP Gain	Homing Offset	CUR Loop Comp
Jog Speed	Current INT Gain		Stator R1
Jog Accel Time	Speed PROP Gain	<b>Security Control</b>	Flux CUR Setting
Jog Decel Time	Speed INT Gain	Security State	Feedback Tests
Jog S-Curve Time	Speed DIFF Gain	Access Timeout	Slip Freq Test
	Position Gain	Access Code	SPD CNTRLR CALC
<b>Keypad Setup</b>	Slip Frequency		
Keypad Stop Key	Feedback Filter	<b>Motor Data</b>	
Keypad Stop Mode	Stator R1	Motor Voltage	
Keypad Run Fwd	Stator X1	Motor Rated Amps	
Keypad Run Rev		Motor Rated SPD	
Keypad Jog Fwd		Motor Rated FREQ	
Keypad Jog Rev		Motor MAG Amps	
Local Hot Start		Encoder Counts	
		Resolver Speed	
		CALC Presets	

**Table 4-2 Level 1 Parameter Block Definitions**

Block Title	Parameter	Description
PRESET SPEEDS	Preset Speeds #1 – #15	Allows selection of 15 predefined motor operating speeds. Each speed may be selected using external switches connected to terminals at J1B. For motor operation, a motor direction command must be given along with a preset speed command.
ACCEL/DECCEL RATE	<p>Accel Time #1,2</p> <p>Decel Time #1,2</p> <p>S-Curve #1,2</p>	<p>Accel time is the number of seconds required for the motor to increase at a linear rate from 0 RPM to the RPM specified in the "Max Output Speed" parameter in the Level 2 Output Limits block.</p> <p>Example: Maximum Output Speed =1000 RPM; Preset Speed = 500 RPM, Accel Time=10 Sec. In this example, motor will be at 500 RPM 5 seconds after commanded because preset is half the max speed.</p> <p>Decel time is the number of seconds required for the motor to decrease at a linear rate from the speed specified in the "Max Output Speed" parameter to 0 RPM.</p> <p>S-Curve is a percentage of the total Accel or Decel time and provides smooth starts and stops. 0% represents no "S" and 100% represents full "S" with no linear segment. Figure 4-2 illustrates how motor acceleration is changed using a 40% S-Curve.</p> <p>Note: Accel #1, Decel #1 and S-Curve #1 are associated together. Likewise, Accel #2, Decel #2 and S-Curve #2 are associated together. These associations can be used to control any Preset Speed or external speed command (pot).</p> <p>Note: If faults (motor trips) occur during rapid Accel or Decel, selecting an S-curve may eliminate the faults without affecting the overall ramp time.</p>
JOG SETTINGS	<p>Jog Speed</p> <p>Jog Accel Time</p> <p>Jog Decel Time</p> <p>Jog S-Curve</p>	<p>Jog Speed changes motor speed to a preset value for jog mode. To cause motor to operate at Jog Speed the FWD or REV key must be pressed or external command Forward (J1B-9) or Reverse (J1B-10) signal is required. The motor will run at jog speed until FWD or REV key is released or external command signal is removed. Jog speed can be less than the minimum speed parameter setting.</p> <p>Jog Accel Time changes the slope of the Jog Accel ramp. It is the time in seconds, from zero speed to maximum speed.</p> <p>Jog Decel Time changes the slope of the Jog Decel ramp. It is the time in seconds, from maximum speed to zero speed.</p> <p>Jog S-Curve changes the S-Curve to a preset value for jog mode.</p>

**Figure 4-2 S-Curve Example**

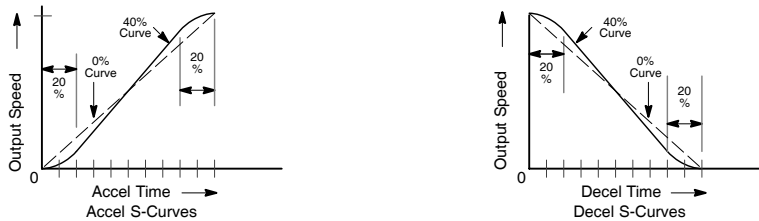



**Table 4-2 Level 1 Parameter Block Definitions - Continued**

Block Title	Parameter	Description
KEYPAD SETUP	Keypad Stop Key	Selects keypad STOP key to initiate motor stop during remote operation (if Stop key is programmed to Remote ON). If active, pressing STOP automatically selects Local mode and initiates the stop command.
	Keypad Stop Mode	Causes the motor to COAST to a stop or REGEN to a stop. In COAST, the motor is turned off and allowed to coast to a stop. In REGEN, the voltage and frequency to the motor is reduced at a rate set by Decel Time.  Note: In REGEN mode, it is possible to cause an Overvoltage Trip if REGEN to stop decelerates the motor too quickly. If a fault occurs, increase the DECEL time.
	Keypad Run FWD	Makes the keypad FWD key active (ON) or inactive (OFF) in Local mode.
	Keypad Run REV	Makes the keypad REV key active (ON) or inactive (OFF) in Local mode.
	Keypad Jog FWD	Makes the keypad FWD key active (ON) or inactive (OFF) in Local Jog mode.
	Keypad Jog REV	Makes the keypad REV key active (ON) or inactive (OFF) in Local Jog mode.
	Loc. Hot Start	Loc. Hot Start - The STOP input at J4-11 in the Keypad mode is enabled (when ON).
INPUT	Operating Mode	Ten "Operating Modes" are available. Choices are: Keypad, Standard Run, 15 Speed, 3 Speed Analog 2 Wire, 3 Speed Analog 3 Wire, Serial, Bipolar, Process Control, Electronic Pot 2 Wire, or Electronic Pot 3 Wire. External connections to the control are made at the J1B terminal strip (wiring diagrams are shown in Section 3).
	Command Select	Selects the external speed reference to be used. The choices are: Potentiometer is the easiest method of speed control. Select POTENTIOMETER and connect a 5kΩ pot to J1A-1, J1A-2, and J1A-3.  ±5 or ±10VDC input command can be applied to J1A-4 and J1A-5.  4 To 20mA may be used if long distance is required between the external speed control and the control, the 4-20mA selections at J1A-4 and J1A-5 should be considered. Current loop allows long cable lengths without attenuation of the command signal.  Note: When using 4-20mA operation, the JP1 jumper on the main control board must be moved to pins 2 and 3. Refer to Section 3.  10 VOLT W/TORQ FF - when a differential command is present at J1A-4 and 5, allows additional torque feedforward input at J1A-1, 2 and 3 to set a predetermined amount of torque inside the rate loop with high gain settings.  EXB PULSE FOL - selects optional Master Pulse Reference/Isolated Pulse Follower expansion board if installed.  5VOLT EXB - selects optional High Resolution I/O expansion board if installed. 10VOLT EXB - selects optional High Resolution I/O expansion board if installed. 4-20mA EXB - selects optional High Resolution I/O expansion board if installed. 3-15 PSI EXB selects optional 3-15 PSI expansion board if installed. Tachometer EXB- selects optional DC Tachometer expansion board if installed. Serial -selects optional Serial Communications expansion board if installed.
	ANA CMD Inverse	"OFF" will cause a low input voltage (e.g. 0VDC) to be a low motor speed command and a maximum input voltage (e.g. 10VDC) to be a maximum motor speed command.  "ON" will cause a low input voltage (e.g. 0VDC) to be a maximum motor speed command and a maximum input voltage (e.g. 10VDC) to be a low motor speed command.
	ANA CMD Offset	Provides an offset to the Analog Input to minimize signal drift. For example, if the minimum speed signal is 1VDC (instead of 0VDC) the ANA CMD Offset can be set to -10% so the minimum voltage input is seen by the control as 0VDC. The value of this parameter is automatically adjusted by the autotune Command Offset Trim test.
	ANA 2 Deadband	Allows a defined range of voltage to be a deadband. A command signal within this range will not affect the control output. The deadband value is the voltage above and below the zero command signal level.
	ANA 1 CUR Limit	Allows the 5V input at J1A-2 (referenced to J1A-1) to be used for reduction of the programmed current limit parameter for torque trimming during operation.

**Table 4-2 Level 1 Parameter Block Definitions - Continued**

Block Title	Parameter	Description																																
OUTPUT	OPTO OUTPUT #1 – #4	<p>Four optically isolated digital outputs that have two operating states, logical High or Low. Each output may be configured to any of the following conditions:</p> <table border="1"> <thead> <tr> <th data-bbox="606 355 706 373">Condition</th> <th data-bbox="735 355 835 373">Description</th> </tr> </thead> <tbody> <tr> <td data-bbox="606 381 706 399">Ready -</td> <td data-bbox="735 381 1292 399">Active when power is applied and no faults are present.</td> </tr> <tr> <td data-bbox="606 407 706 425">Zero Speed -</td> <td data-bbox="735 407 1292 451">Active when output speed is below the programmed value of the "Zero SPD Set Pt" Level 1 Output parameter.</td> </tr> <tr> <td data-bbox="606 460 706 477">At Speed -</td> <td data-bbox="735 460 1292 503">Active when output speed is within the speed range defined by the "At Speed Band" Level 1 Output parameter.</td> </tr> <tr> <td data-bbox="606 512 706 529">At Set Speed -</td> <td data-bbox="735 512 1292 555">Active when output speed is at or above the "Set Speed Point" Level 1 Output parameter.</td> </tr> <tr> <td data-bbox="606 564 706 581">Overload -</td> <td data-bbox="735 564 1292 616">A normally closed contact that is active (opens) during an Overload fault caused by a timeout when the output current is greater than Rated Current.</td> </tr> <tr> <td data-bbox="606 624 706 642">Keypad Control -</td> <td data-bbox="735 624 1292 642">Active when control is in Local keypad control.</td> </tr> <tr> <td data-bbox="606 651 706 668">Fault -</td> <td data-bbox="735 651 1292 668">Active when a fault condition is present.</td> </tr> <tr> <td data-bbox="606 677 706 694">Following ERR -</td> <td data-bbox="735 677 1292 720">Active when the motor speed is outside the user specified tolerance band defined by the AT Speed Band parameter.</td> </tr> <tr> <td data-bbox="606 729 706 746">Drive On -</td> <td data-bbox="735 729 1292 772">Active when control is "Ready" (has reached excitation level and capable of producing torque).</td> </tr> <tr> <td data-bbox="606 781 706 798">CMD Direction -</td> <td data-bbox="735 781 1292 824">Active when Forward or Reverse is enabled. Logical output state indicates Forward or Reverse direction.</td> </tr> <tr> <td data-bbox="606 833 706 850">AT Position -</td> <td data-bbox="735 833 1292 876">Active during a serial positioning command when control is within the Position Band tolerance parameter.</td> </tr> <tr> <td data-bbox="606 885 706 902">Over Temp Warn -</td> <td data-bbox="735 885 1292 928">Active when control heatsink temperature is within 3°C of the INT. Overtemp value.</td> </tr> <tr> <td data-bbox="606 937 706 954">Process Error -</td> <td data-bbox="735 937 1292 989">Active when the process feedback signal is outside the process error tolerance (PROC ERR TOL) parameter value. Turns off when process feedback error is within tolerance.</td> </tr> <tr> <td data-bbox="606 1015 706 1032">Drive Run -</td> <td data-bbox="735 1015 1292 1058">Active when drive is Ready, Enabled, Speed or Torque command is received and FWD or REV command is issued.</td> </tr> <tr> <td data-bbox="606 1085 706 1102">Serial -</td> <td data-bbox="735 1085 1292 1102">Active when drive is in the Serial mode.</td> </tr> </tbody> </table>	Condition	Description	Ready -	Active when power is applied and no faults are present.	Zero Speed -	Active when output speed is below the programmed value of the "Zero SPD Set Pt" Level 1 Output parameter.	At Speed -	Active when output speed is within the speed range defined by the "At Speed Band" Level 1 Output parameter.	At Set Speed -	Active when output speed is at or above the "Set Speed Point" Level 1 Output parameter.	Overload -	A normally closed contact that is active (opens) during an Overload fault caused by a timeout when the output current is greater than Rated Current.	Keypad Control -	Active when control is in Local keypad control.	Fault -	Active when a fault condition is present.	Following ERR -	Active when the motor speed is outside the user specified tolerance band defined by the AT Speed Band parameter.	Drive On -	Active when control is "Ready" (has reached excitation level and capable of producing torque).	CMD Direction -	Active when Forward or Reverse is enabled. Logical output state indicates Forward or Reverse direction.	AT Position -	Active during a serial positioning command when control is within the Position Band tolerance parameter.	Over Temp Warn -	Active when control heatsink temperature is within 3°C of the INT. Overtemp value.	Process Error -	Active when the process feedback signal is outside the process error tolerance (PROC ERR TOL) parameter value. Turns off when process feedback error is within tolerance.	Drive Run -	Active when drive is Ready, Enabled, Speed or Torque command is received and FWD or REV command is issued.	Serial -	Active when drive is in the Serial mode.
	Condition	Description																																
	Ready -	Active when power is applied and no faults are present.																																
	Zero Speed -	Active when output speed is below the programmed value of the "Zero SPD Set Pt" Level 1 Output parameter.																																
At Speed -	Active when output speed is within the speed range defined by the "At Speed Band" Level 1 Output parameter.																																	
At Set Speed -	Active when output speed is at or above the "Set Speed Point" Level 1 Output parameter.																																	
Overload -	A normally closed contact that is active (opens) during an Overload fault caused by a timeout when the output current is greater than Rated Current.																																	
Keypad Control -	Active when control is in Local keypad control.																																	
Fault -	Active when a fault condition is present.																																	
Following ERR -	Active when the motor speed is outside the user specified tolerance band defined by the AT Speed Band parameter.																																	
Drive On -	Active when control is "Ready" (has reached excitation level and capable of producing torque).																																	
CMD Direction -	Active when Forward or Reverse is enabled. Logical output state indicates Forward or Reverse direction.																																	
AT Position -	Active during a serial positioning command when control is within the Position Band tolerance parameter.																																	
Over Temp Warn -	Active when control heatsink temperature is within 3°C of the INT. Overtemp value.																																	
Process Error -	Active when the process feedback signal is outside the process error tolerance (PROC ERR TOL) parameter value. Turns off when process feedback error is within tolerance.																																	
Drive Run -	Active when drive is Ready, Enabled, Speed or Torque command is received and FWD or REV command is issued.																																	
Serial -	Active when drive is in the Serial mode.																																	
	Zero SPD Set PT	Sets the RPM at which the Zero Speed opto output becomes active (turns on). When the speed is less than the ZERO SPD SET PT, the opto output becomes active. This is useful when a motor brake is to interlock operation with a motor.																																
	At Speed Band	<p>The At Speed Band serves two opto output conditions and the Level 2 Protection block Following Error:</p> <p>Sets the speed range in RPM at which the At Speed opto output turns on and remains active within the range.</p> <p>Sets the Following Error Tolerance Band for the Level 1 OUTPUT, opto output condition Following ERR. The opto output is active if the motor speed is outside this band.</p> <p>Sets allowable following error speed band of the drive. This value is used by the Level 2 Protection block, Following Error parameter (if it is set to ON). If the drive speed falls out of this band, the Level 2 Protection block, Following Error parameter will shut down the drive (if it is set to ON).</p>																																
	Set Speed Point	Sets the RPM at which the AT Set Speed opto output becomes active (turns on). When the speed is greater than the SET SPEED POINT, the opto output becomes active. This is useful when another machine must not start until the motor exceeds a predetermined speed.																																

**Table 4-2 Level 1 Parameter Block Definitions - Continued**

Block Title	Parameter	Description																																																		
OUTPUT (Continued)	Analog Output #1 and #2	<p>Two Linear Analog outputs may be configured to represent any of the following conditions: (note 0-10VDC or <math>\pm 10</math>VDC operation per condition)</p> <table border="0"> <thead> <tr> <th>Condition</th> <th>Description</th> </tr> </thead> <tbody> <tr> <td>ABS Speed -</td> <td>Represents the absolute motor speed where 0VDC = 0 RPM and 10VDC = MAX RPM.</td> </tr> <tr> <td>ABS Torque -</td> <td>Represents the absolute value of torque where 10VDC = Torque at CURRENT LIMIT.</td> </tr> <tr> <td>Speed Command -</td> <td>Represents the absolute value of commanded speed where 0VDC=0 RPM and +10VDC = MAX RPM.</td> </tr> <tr> <td>PWM Voltage -</td> <td>Represents the amplitude of PWM voltage where 10VDC = MAX AC Voltage.</td> </tr> <tr> <td>Flux Current -</td> <td>0-10VDC represents actual portion of total current used for excitation. 10VDC = Maximum flux current.</td> </tr> <tr> <td>CMD Flux CUR -</td> <td>0-10VDC represents calculated portion of total current used for excitation. 10VDC = Maximum commanded flux current.</td> </tr> <tr> <td>Load Current -</td> <td>Represents actual portion of total current used to produce torque (CW and CCW torque). +10VDC=Maximum CW Torque, -10VDC=Maximum CCW Torque.</td> </tr> <tr> <td>CMD Load Current -</td> <td>0-10VDC represents calculated portion of total current used to produce torque. 10VDC=Maximum commanded load current.</td> </tr> <tr> <td>Motor Current -</td> <td>Amplitude of continuous current including motor excitation current. 10V = rated Current.</td> </tr> <tr> <td>Load Component -</td> <td>Amplitude of load current not including the motor excitation current. 10V = rated current.</td> </tr> <tr> <td>Quad Voltage -</td> <td>0-10VDC represents load controller output (quadrature voltage). Useful when diagnosing control problems.</td> </tr> <tr> <td>Direct Voltage -</td> <td>0-10VDC represents flux controller output. Useful to troubleshoot control problems.</td> </tr> <tr> <td>AC Voltage -</td> <td>PWM control voltage which is proportional to AC line to line motor terminal voltage. 0VDC = Neg. Peak PWM voltage, 5V centered, 10VDC = Pos. Peak PWM voltage. At rated motor voltage, a full 0 to 10V sinusoidal waveform at or greater than the motor base frequency would be present. At half the motor base frequency, a 2.5V to 7.5V sinusoidal waveform would be present. The waveform is centered around 5V.</td> </tr> <tr> <td>Bus Voltage -</td> <td>Amplitude of control bus voltage, 10V = 1000VDC.</td> </tr> <tr> <td>Torque -</td> <td>Bipolar torque output. 0V = Max negative torque, 5V centered, 10V = Max Positive Torque.</td> </tr> <tr> <td>Power -</td> <td>Bipolar power output. 0V = negative rated peak power, 5V = Zero Power, 10V = Positive rated peak power.</td> </tr> <tr> <td>Velocity -</td> <td>Represents motor speed scaled to 0V = negative max RPM, 5V = Zero Speed, 10V = positive max RPM.</td> </tr> <tr> <td>Overload -</td> <td><math>(\text{Accumulated current})^2 \times (\text{time})</math>, Overload indication occurs at 10V.</td> </tr> <tr> <td>PH 2 Current -</td> <td>Sampled AC phase 2 motor current. 0V = negative rated peak amps, 5V = zero amps, 10V = positive rated peak amps.</td> </tr> <tr> <td>PH 1 Current -</td> <td>Sampled AC phase 1 motor current. 0V = negative rated peak amps, 5V = zero amps, 10V = positive rated peak amps.</td> </tr> <tr> <td>Process FB. -</td> <td><math>\pm 10</math>VDC represents <math>\pm 100\%</math> of Process Feedback signal.</td> </tr> <tr> <td>Setpoint CMD -</td> <td><math>\pm 10</math>VDC represents <math>\pm 100\%</math> of Setpoint signal.</td> </tr> <tr> <td>Position -</td> <td>Position within a single revolution. 10V = 1 complete revolution. The counter will reset to 0 every revolution.</td> </tr> <tr> <td>Serial -</td> <td>0-5VDC level that represents a value programmed by a serial command.</td> </tr> </tbody> </table>	Condition	Description	ABS Speed -	Represents the absolute motor speed where 0VDC = 0 RPM and 10VDC = MAX RPM.	ABS Torque -	Represents the absolute value of torque where 10VDC = Torque at CURRENT LIMIT.	Speed Command -	Represents the absolute value of commanded speed where 0VDC=0 RPM and +10VDC = MAX RPM.	PWM Voltage -	Represents the amplitude of PWM voltage where 10VDC = MAX AC Voltage.	Flux Current -	0-10VDC represents actual portion of total current used for excitation. 10VDC = Maximum flux current.	CMD Flux CUR -	0-10VDC represents calculated portion of total current used for excitation. 10VDC = Maximum commanded flux current.	Load Current -	Represents actual portion of total current used to produce torque (CW and CCW torque). +10VDC=Maximum CW Torque, -10VDC=Maximum CCW Torque.	CMD Load Current -	0-10VDC represents calculated portion of total current used to produce torque. 10VDC=Maximum commanded load current.	Motor Current -	Amplitude of continuous current including motor excitation current. 10V = rated Current.	Load Component -	Amplitude of load current not including the motor excitation current. 10V = rated current.	Quad Voltage -	0-10VDC represents load controller output (quadrature voltage). Useful when diagnosing control problems.	Direct Voltage -	0-10VDC represents flux controller output. Useful to troubleshoot control problems.	AC Voltage -	PWM control voltage which is proportional to AC line to line motor terminal voltage. 0VDC = Neg. Peak PWM voltage, 5V centered, 10VDC = Pos. Peak PWM voltage. At rated motor voltage, a full 0 to 10V sinusoidal waveform at or greater than the motor base frequency would be present. At half the motor base frequency, a 2.5V to 7.5V sinusoidal waveform would be present. The waveform is centered around 5V.	Bus Voltage -	Amplitude of control bus voltage, 10V = 1000VDC.	Torque -	Bipolar torque output. 0V = Max negative torque, 5V centered, 10V = Max Positive Torque.	Power -	Bipolar power output. 0V = negative rated peak power, 5V = Zero Power, 10V = Positive rated peak power.	Velocity -	Represents motor speed scaled to 0V = negative max RPM, 5V = Zero Speed, 10V = positive max RPM.	Overload -	$(\text{Accumulated current})^2 \times (\text{time})$ , Overload indication occurs at 10V.	PH 2 Current -	Sampled AC phase 2 motor current. 0V = negative rated peak amps, 5V = zero amps, 10V = positive rated peak amps.	PH 1 Current -	Sampled AC phase 1 motor current. 0V = negative rated peak amps, 5V = zero amps, 10V = positive rated peak amps.	Process FB. -	$\pm 10$ VDC represents $\pm 100\%$ of Process Feedback signal.	Setpoint CMD -	$\pm 10$ VDC represents $\pm 100\%$ of Setpoint signal.	Position -	Position within a single revolution. 10V = 1 complete revolution. The counter will reset to 0 every revolution.	Serial -	0-5VDC level that represents a value programmed by a serial command.
Condition	Description																																																			
ABS Speed -	Represents the absolute motor speed where 0VDC = 0 RPM and 10VDC = MAX RPM.																																																			
ABS Torque -	Represents the absolute value of torque where 10VDC = Torque at CURRENT LIMIT.																																																			
Speed Command -	Represents the absolute value of commanded speed where 0VDC=0 RPM and +10VDC = MAX RPM.																																																			
PWM Voltage -	Represents the amplitude of PWM voltage where 10VDC = MAX AC Voltage.																																																			
Flux Current -	0-10VDC represents actual portion of total current used for excitation. 10VDC = Maximum flux current.																																																			
CMD Flux CUR -	0-10VDC represents calculated portion of total current used for excitation. 10VDC = Maximum commanded flux current.																																																			
Load Current -	Represents actual portion of total current used to produce torque (CW and CCW torque). +10VDC=Maximum CW Torque, -10VDC=Maximum CCW Torque.																																																			
CMD Load Current -	0-10VDC represents calculated portion of total current used to produce torque. 10VDC=Maximum commanded load current.																																																			
Motor Current -	Amplitude of continuous current including motor excitation current. 10V = rated Current.																																																			
Load Component -	Amplitude of load current not including the motor excitation current. 10V = rated current.																																																			
Quad Voltage -	0-10VDC represents load controller output (quadrature voltage). Useful when diagnosing control problems.																																																			
Direct Voltage -	0-10VDC represents flux controller output. Useful to troubleshoot control problems.																																																			
AC Voltage -	PWM control voltage which is proportional to AC line to line motor terminal voltage. 0VDC = Neg. Peak PWM voltage, 5V centered, 10VDC = Pos. Peak PWM voltage. At rated motor voltage, a full 0 to 10V sinusoidal waveform at or greater than the motor base frequency would be present. At half the motor base frequency, a 2.5V to 7.5V sinusoidal waveform would be present. The waveform is centered around 5V.																																																			
Bus Voltage -	Amplitude of control bus voltage, 10V = 1000VDC.																																																			
Torque -	Bipolar torque output. 0V = Max negative torque, 5V centered, 10V = Max Positive Torque.																																																			
Power -	Bipolar power output. 0V = negative rated peak power, 5V = Zero Power, 10V = Positive rated peak power.																																																			
Velocity -	Represents motor speed scaled to 0V = negative max RPM, 5V = Zero Speed, 10V = positive max RPM.																																																			
Overload -	$(\text{Accumulated current})^2 \times (\text{time})$ , Overload indication occurs at 10V.																																																			
PH 2 Current -	Sampled AC phase 2 motor current. 0V = negative rated peak amps, 5V = zero amps, 10V = positive rated peak amps.																																																			
PH 1 Current -	Sampled AC phase 1 motor current. 0V = negative rated peak amps, 5V = zero amps, 10V = positive rated peak amps.																																																			
Process FB. -	$\pm 10$ VDC represents $\pm 100\%$ of Process Feedback signal.																																																			
Setpoint CMD -	$\pm 10$ VDC represents $\pm 100\%$ of Setpoint signal.																																																			
Position -	Position within a single revolution. 10V = 1 complete revolution. The counter will reset to 0 every revolution.																																																			
Serial -	0-5VDC level that represents a value programmed by a serial command.																																																			

**Table 4-2 Level 1 Parameter Block Definitions - Continued**

<b>Block Title</b>	<b>Parameter</b>	<b>Description</b>
OUTPUT (Continued)	Analog Scale #1 and #2	Scale factor for the Analog Output voltage. Useful to set the zero value or full scale range for external meters.
	ANA OUT Offset	Adjusts the offset for the Analog Output voltage from zero reference.
	Position Band	Sets the acceptable range in digital counts (pulses) at which the AT Position Opto becomes active (turns on).
Vector Control	CTRL BASE Speed	Sets the speed in RPM at which the saturation voltage of the control is reached. Above this RPM value the control will output constant voltage and variable frequency.
	Feedback Filter	A larger value provides a more filtered signal but at the cost of reduced bandwidth.
	Feedback Align	Sets the encoder's electrical direction of rotation to match that of the motor.
	Current PROP Gain	Sets the current loop proportional gain.
	Current INT Gain	Sets the current loop integral gain.
	Speed PROP Gain	Sets the speed (velocity) loop proportional gain.
	Speed INT Gain	Sets the speed (velocity) loop integral gain.
	Speed DIFF Gain	Sets the speed (velocity) loop differential gain.
	Position Gain	Sets the position loop proportional gain.
	Slip Frequency	Sets the rated slip frequency of the motor.
	Stator R1	Stator resistance in ohms. If set too high, the motor will tend to stall at zero speed when reversing or accelerating from low speed. Reducing this value will eliminate the problem. When too low, speed regulation may suffer.
	Stator X1	Stator leakage inductance, in ohms at 60Hz. This parameter has most impact when reversing motor rotation at full current limit. If set too low, the true decel time will tend to increase.
LEVEL 2 BLOCK		ENTERS LEVEL 2 MENU

**Table 4-3 Level 2 Parameter Block Definitions**

<b>Block Title</b>	<b>Parameter</b>	<b>Description</b>
OUTPUT LIMITS	MIN Output Speed	Sets the minimum motor speed in RPM. During operation, the motor speed will not be allowed to go below this value except for motor starts from 0 RPM or during a stop.
	MAX Output Speed	Sets the maximum motor speed in RPM.
	PK Current Limit	The maximum output peak current to the motor. Values above 100% of the rated current are available depending upon the operating zone selected.
	PWM Frequency	The frequency that the output transistors are switched. PWM frequency is also referred to as "Carrier" frequency. PWM should be as low as possible to minimize stress on the output transistors and motor windings. It is recommended that the PWM frequency be set to approximately 15 times the maximum output frequency of the control. Ratios less than 15 will result in non-Sinusoidal current waveforms. Note: Derate output current by 30% for operation between 8.5KHz and 16KHz.
	CUR Rate Limit	Limits the rate of change of a torque command.

**Table 4-3 Level 2 Parameter Block Definitions - Continued**

Block Title	Parameter	Description
CUSTOM UNITS	Decimal Places	The number of decimal places of the output rate display on the Keypad display. This value will be automatically reduced for large values. The output rate display is only available if the Value At Speed parameter is nonzero.
	Value At Speed	Sets the desired output rate per RPM of motor speed. Two numbers are displayed on the keypad display (separated by a slash "/"). The first number (left most) is the value you want the keypad to display at a specific motor speed. The second number (right most) is the motor RPM corresponding to the units in the first number. A decimal may be inserted into the left numbers by placing the flashing cursor over the up/down arrow and using the arrow keys.
	Units of Measure	Allows user specified units of measure to be displayed on the Keypad display. Use the shift and arrow keys to scroll to the first and successive characters. If the character you want is not displayed, move the flashing cursor over the special up/down character arrow on the left side of the display. Use the up/down arrows and the shift key to scroll through all 9 character sets. Use the ENTER key to save your selection.
PROTECTION	Overload	Sets the protection mode to Fault (trip off during overload condition) or to Foldback (automatically reduce the output current below the continuous output level) during an overload. Foldback is the choice if continuous operation is desired. Fault will require the control be "Reset" after an overload.
	External Trip	OFF - External Trip is Disabled. ON - When a normally closed contact at J1B-16 is opened will cause an External Trip fault and will cause the drive to shut down.
	Local Enable INP	OFF - Local enable input is Disabled. (Control is enabled without J1B-8 connection). ON - When a contact at J1B-8 is closed (to J1B-17 common), the control is enabled.
	Following Error	This parameter determines if the control is to monitor the amount of following error that occurs in an application. Following Error is the programmable tolerance for the AT Speed opto output. Operation outside the tolerance range will cause a fault and the drive will shut down.
	Torque Proving	When this parameter is set to ON the control looks for balanced output current in all three phases to the motor. If output current is unbalanced, the control will trip off generating a torque proving fault. In a hoist application, for example, this is useful to ensure that motor torque exists before the fail safe brake is released. "Drive On" output, if programmed, will not occur if torque proving fails.
MISCELLANEOUS	Restart Auto/Man	Manual - If a fault occurs, the control must be manually reset to resume operation. Automatic - If a fault occurs, the control will automatically reset to resume operation.
	Restart Fault/Hr	The maximum number of automatic restart attempts before requiring a manual restart. After one hour without reaching the maximum number of faults or if power is turned off and on again, the fault count is reset to zero.
	Restart Delay	The amount of time allowed after a fault condition for an automatic restart to occur. Useful to allow sufficient time to clear a fault before restart is attempted.
	Factory Settings	Restores factory settings for all parameter values. Select YES and press "ENTER" key to restore factory parameter values. The keypad Display will show "Operation Done" then return to "NO" when completed.  Note: When factory settings are reset, the Motor Rated Amps value is reset to 999.9 amps. This Level 2 Motor Data block parameter value must be changed to the correct value (located on the motor rating plate) before attempting to start the drive.
	Homing Speed	In Bipolar mode, this parameter sets the speed that the motor shaft will rotate to a "Home" position when the orient command is issued.
	Homing Offset	In Bipolar mode, this parameter sets the number of encoder counts past home at which the motor stop command is issued. The recommended minimum is 100 encoder counts to allow deceleration distance for the motor to stop smoothly.  Note: Homing direction is always in the drive forward direction.

**Table 4-3 Level 2 Parameter Block Definitions** Continued

Block Title	Parameter	Description
SECURITY CONTROL	Security State	Off - No security Access Code required to change parameter values. Local - Requires security Access Code to be entered (using the keypad) before parameter changes can be made using the Keypad. Total - Requires security Access Code to be entered (using Keypad) before parameter changes can be made using the Keypad.  Note: If security is set to Local, Serial or Total you can press PROG and scroll through the parameter values and view their values but you are not allowed to change their values unless you enter the correct access code.
	Access Timeout	The time in seconds the security access remains enabled after leaving the programming mode. If you exit and go back into the program mode within this time limit, the security Access Code does not have to be re-entered. This timer starts when leaving the program mode (by pressing DISP). Only active with Local Security.
	Access Code	A 4 digit number code. Only persons that know the code can change secured parameter values. When changing the code, the new number will not be displayed.  Note: Please record your access code and store it in a safe place. If you cannot gain entry into parameter values to change a protected parameter, please contact your local Baldor office. Be prepared to give the 5 digit code shown on the lower right side of the Keypad Display at the Security Control Access Code parameter prompt.
MOTOR DATA	Motor Voltage	The rated voltage of the motor (listed on the motor nameplate).
	Motor Rated Amps	The rated current of the motor (listed on the motor nameplate). If the motor current exceeds this value for a period of time, an Overload fault will occur.
	Motor Rated SPD	The rated speed of the motor (listed on the motor nameplate).
	Motor Rated Freq	The rated frequency of the motor (listed on the motor nameplate).
	Motor Mag Amps	The motor magnetizing current value (listed on the motor nameplate) also called no load current. Measure using a clamp on amp meter at the AC power line while the motor is running at line frequency with no load connected to the motor shaft.
	Encoder Counts	The number of encoder feedback counts (lines per revolution).  Note: Reducing this parameter value to zero will cause the vector control to operate as a sensorless control.
	Resolver Speed	The speed of the resolver, if a resolver is used for feedback.
CALC Presets	This procedure loads preset values into memory that are required to perform Auto Tune. Always run CALC Presets as the first step of Auto Tune.	
PROCESS CONTROL	Process Feedback	Sets the type of signal used for the process feedback signal.
	Process Inverse	Causes the process feedback signal to be inverted. Used with reverse acting processes that use a unipolar signal such as 4-20mA. If "ON", 20mA will decrease motor speed and 4mA will increase motor speed.
	Setpoint Source	Sets the source input signal type to which the process feedback will be compared. If "Setpoint CMD" is selected, the fixed value of the set point is entered in the Setpoint Command parameter value.
	Setpoint Command	Sets the value of the setpoint the control will try to maintain by adjusting motor speed. This is only used when the Setpoint Source is a fixed value "Setpoint CMD" under Setpoint Source.
	Set PT ADJ Limit	Sets the maximum speed correction value to be applied to the motor (in response to the maximum feedback setpoint error). For example, if the max motor speed is 1750 RPM, the setpoint feedback error is 100% and the setpoint adjustment limit is 10%, the maximum speed adjustment in response to the setpoint feedback error is $\pm 175$ RPM.
	Process ERR TOL	Sets the width of the comparison band (% of setpoint) with which the process input is compared. The result is that if the process input is within the comparison band the corresponding opto output will become active.
	Process PROP Gain	Sets the PID loop proportional gain. This determines how much adjustment to motor speed or torque (within the Set PT ADJ Limit) is made to reduce process error.

**Table 4-3 Level 2 Parameter Block Definitions** Continued

Block Title	Parameter	Description
PROCESS CONTROL Continued	Process INT Gain	Sets the PID loop Integral gain. This determines how quickly the motor speed or torque is adjusted to correct long term error.
	Process DIFF Gain	Sets the PID loop differential gain. This determines how much adjustment to motor speed or torque (within the Set PT ADJ Limit) is made for transient error.
	Follow I:O Ratio	Sets the ratio of the Master to the Follower in Master/Follower configurations. Requires the Master Pulse Reference/ Isolated Pulse Follower expansion board. For example, the master encoder you want to follow is a 1024 count encoder. The follower motor you wish to control also has a 1024 count encoder on it. If you wish the follower to run twice the speed of the master, a 1:2 ratio is entered. Fractional ratios such as 0.5:1 are entered as 1:2. Master:Follower ratio limits are (1-65,535) : (1-20).  Note: The Master Encoder parameter must be defined if a value is entered in the Follow I:O Ratio parameter.
	Follow I:O Out	This parameter is used only when Serial Communications is used to operate the control. A Master Pulse Reference/ Isolated Pulse Follower expansion board is required. This parameter represents the FOLLOWER portion of the ratio. The MASTER portion of the ratio is set in the Follow I:O Ratio parameter.
	Master Encoder	Only used if an optional Master Pulse Reference/Isolated Pulse Follower expansion board is installed and the Level 1 Input block, Command Select parameter is set to EXB Pulse Fol. Defines the number of pulses per revolution of the master encoder. Programmed into follower drives only.
COMMUNICATIONS	Protocol	Sets the type of communication the control is to use RS-232 or RS-485 ASCII (text) protocol, or RS-232 or RS-485 BBP (Baldor Binary Protocol).
	Baud Rate	Sets the speed at which communication is to occur.
	Drive Address	Sets the address of the control for communication.
AUTO TUNING		The Auto Tune procedure is used to automatically measure and calculate certain parameter values. Dynamic Brake Hardware is required to perform "Slip Freq Test" and "Spd Cntrlr Calc" autotuning test. To use the autotune procedure, the load must be disconnected from the motor shaft for all tests except the SPD CNTRLR CALC test which must have the motor load connected. Occasionally, the Auto Tune procedure cannot be run due to various circumstances such as the load cannot be uncoupled from the motor. The control can be manually tuned by entering the parameter values based on calculations you have made. Refer to "Manually Tuning the Control" in the Troubleshooting section of this manual.
	CALC Presets	This procedure loads preset values into memory that are required to perform Auto Tune. Always run CALC Presets as the first step of Auto Tune.
	CMD Offset Trim	This procedure trims out voltage offsets for the differential analog input at J1A-4 and J1A-5.
	CUR Loop COMP	Measures current response to pulses of one half the rated motor current.
	Stator R1	Measures the motors stator resistance.
	Flux CUR Setting	Sets motor magnetizing current by running motor at near rated speed.
	Feedback Tests	Checks the values for Encoder Lines per revolution and encoder alignment parameters while the motor is running at near full rated speed. Test will automatically switch encoder phasing to match motor rotational direction.
Slip FREQ Test	Calculates motor Slip Frequency during repeated motor accelerations.	
SPD CNTRLR CALC	Should be performed with the load coupled to the motor shaft. Sets the motor current to acceleration ratio, Speed INT gain and Speed PROP gain values. If done under no load, the Integral gain will be too large for high inertia loads if the PK Current Limit is set too low. If the control is too responsive when the drive is loaded, adjust the PK Current Limit parameter to a greater value and repeat this test.	
LEVEL 1 BLOCK		ENTERS LEVEL 1 MENU

## Section 5 Troubleshooting

### Overview

The Baldor Series 25M Control requires very little maintenance and should provide years of trouble free operation when installed and applied correctly. Occasional visual inspection and cleaning should be considered to ensure tight wiring connections and to remove dust, dirt, or foreign debris which can reduce heat dissipation.

Operational failures called "Faults" will be displayed on the Keypad Display as they occur. A comprehensive list of these faults, their meaning and how to access the fault log and diagnostic information is provided later in this section. Troubleshooting information is provided in table format later in this section.

Before attempting to service this equipment, all input power should be removed from the control to avoid the possibility of electrical shock. The servicing of this equipment should be handled by a qualified electrical service technician experienced in the area of high power electronics.

It is important to familiarize yourself with the following information before attempting any troubleshooting or service of the control. Most troubleshooting can be performed using only a digital voltmeter having an input impedance exceeding 1 megohm. In some cases, an oscilloscope with 5 MHz minimum bandwidth may be useful. Before consulting the factory, check that all power and control wiring is correct and installed per the recommendations given in this manual.

### PSM-PR Troubleshooting Procedure

#### Display Identification

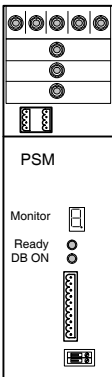

Troubleshooting the Power Supply Module (PSM) involves observing the status of the "Ready" LED, the "DB On" LED and the "Monitor" 7 segment display. Table 5-1 defines the indications provided by these devices.

The DB LED is on whenever Dynamic Brake power is dissipated into the the DB (Dynamic Brake) resistor.

**Table 5-1 Operating Mode Indications**

Ready	Monitor	Status
OFF	OFF	Control disabled or powered off
Green	Decimal Point	Control enabled, normal operation, no faults
OFF	0	Phase loss
OFF	1	Source undervoltage
OFF	2	Bus undervoltage
OFF	3	Loss of source phase
OFF	4	Overtemperature
OFF	5	Dynamic brake fault
OFF	6	Source or bus overvoltage
Green	L	Softstart active

### 25M-PO Ready LED

The 25M control has a "Ready" LED on the panel. If a PSM fault occurs, the Ready LED will be OFF for all controls connected to that PSM and those controls are disabled. Additional troubleshooting procedures are described on the following pages "Control Module Troubleshooting Procedure".

### 25M-TR Indicators

The control has a "Ready" LED on the panel. If a fault occurs, the Ready LED will be OFF and the control is disabled. Additional troubleshooting procedures are described on the following pages "Control Troubleshooting Procedure".

The DB LED is on whenever Dynamic Brake power is dissipated into the DB (Dynamic Brake) resistor. DB resistor is also called a Regen resistor.







---

## Control Module Troubleshooting Procedure

### No Keypad Display - Display Contrast Adjustment

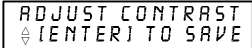
At power up, the display may be blank if the contrast is improperly set. Use the following procedure to adjust the display contrast.

Action	Description	Display	Comments
Apply Power	No visible display.		
Press DISP key	Puts control in Display mode.		Display mode with nothing visible (blank) or too dim to be read.
Press SHIFT key 2 times	Accesses display contrast adjustment.		
Press ▲ or ▼ key	Adjusts display contrast (intensity).		
Press ENTER key	Saves display contrast adjustment level and exits to display mode.		

**Table 5-2 25M Fault Messages**

FAULT MESSAGE	DESCRIPTION
Comm Watchdog	Indicates a problem with the serial communications.
Current Sens FLT	Defective phase current sensor or open circuit detected between control board and current sensor.
DC Bus High	Bus over voltage condition occurred.
DC Bus Low	Bus under voltage condition occurred.
Encoder Loss	Encoder coupling slipping or broken; noise on encoder lines or encoder power supply loss.
External Trip	An external over temperature condition occurred or open circuit on J1B-16.
Following ERR	Excessive following error detected between command and feedback signals.
INT Over-Temp	Temperature of control heatsink exceeded safe level.
Invalid Base ID	Control does not recognize power base ID.
Logic Supply FLT	Logic power supply not working properly.
Lost User Data	Battery backed RAM parameters have been lost or corrupted. When fault cleared (Reset), the control will reset to factory preset values.
New Base ID	Control board was changed since last operation.
No Faults	Fault log is empty.
No EXB Installed	Programmed parameter requires an expansion board.
Overload	Output current exceeded 1.5 or 7 second rating.
Over speed	Motor RPM exceeded 110% of programmed MAX Motor Speed.
µP Reset	Power cycled before the residual Bus voltage reached 0VDC.
Power Module	Affects shared bus multi axis systems only. Indicates power supply failure.
PWR Base FLT	Desaturation of power device occurred or bus current threshold exceeded.
Resolver Loss	Resolver feedback problem is indicated (if resolver used).
Torque Prove FLT	Unbalanced current between all 3 motor phases.
User Fault Text	Custom software operating fault occurred.
Co Processor FLT	Fault detected in the Co Processor function.
Feedback Module	Indicates a problem with the feedback device.

### How to Access the Fault Log

When a fault condition occurs, motor operation stops and a fault code is displayed on the keypad display. The control keeps a log of up to the last 31 faults. If more than 31 faults have occurred, the oldest fault will be deleted from the fault log to make room for the newest fault. To access the fault log use the following procedure:

Action	Description	Display	Comments
Apply Power		BALDOR MOTORS & DRIVES	Logo display for 5 seconds.
	Display mode showing output speed	STOP MOTOR SPEED LOCAL 0 RPM	Display mode.
Press DISP key 5 times	Use DISP key to scroll to the Fault Log entry point.	PRESS ENTER FOR FAULT LOG	
Press ENTER key	Display first fault type and time fault occurred.	EXTERNAL TRIP 1: 0:00:30	1 = Most recent fault. 2 = Next recent fault. ETC.
Press ▲ key	Scroll through fault messages.	PRESS ENTER FOR FAULT LOG EXIT	If no messages, the fault log exit choice is displayed.
Press ENTER key	Return to display mode.	STOP MOTOR SPEED LOCAL 0 RPM	

**How to Clear the Fault Log** Use the following procedure to clear the fault log and reset the internal clock.

Action	Description	Display	Comments
Apply Power		BALDOR MOTORS & DRIVES	Logo display for 5 seconds.
	Display mode showing output speed.	STOP MOTOR SPEED LOCAL 0 RPM	Display mode.
Press DISP key	Press DISP to scroll to the Fault Log entry point.	PRESS ENTER FOR FAULT LOG	
Press ENTER key	Displays most recent message.	EXTERNAL TRIP 1: 00000:00:30	
Press SHIFT key		EXTERNAL TRIP 1: 00000:00:30	
Press RESET key		EXTERNAL TRIP 1: 00000:00:30	
Press SHIFT key		EXTERNAL TRIP 1: 00000:00:30	
Press ENTER key	Fault log is cleared.	FAULT LOG NO FAULTS	No faults in fault log.
Press ▲ or ▼ key	Scroll Fault Log Exit.	PRESS ENTER FOR FAULT LOG EXIT	
Press ENTER key	Return to display mode.	STOP MOTOR SPEED LOCAL 0 RPM	

## How to Access Diagnostic Information

Action	Description	Display	Comments
Apply Power		BALDOR MOTORS & DRIVES	Logo display for 5 seconds.
	Display mode showing speed in RPM.	STOP MOTOR SPEED LOCAL 0 RPM	No faults present. LOCAL keypad mode. If in remote/serial mode, press local for this display.
Press DISP key	Display showing motor frequency.	STOP FREQUENCY LOCAL 0.00 HZ	
Press DISP key	Scroll to diagnostic info block.	PRESS ENTER FOR DIAGNOSTIC INFO	
Press ENTER key	Access diagnostic information.	STOP SPEED REF LOCAL 0 RPM	Displays commanded speed, direction of rotation, Local/Remote.
Press DISP key	Display mode showing control temperature.	STOP CONTROL TEMP LOCAL 0.0°C	Displays operating temperature in degrees C.
Press DISP key	Display mode showing bus voltage.	STOP BUS VOLTAGE LOCAL 321V	
Press DISP key	Display mode showing % overload current remaining.	STOP OVRLD LEFT LOCAL 100.00%	
Press DISP key	Display mode showing opto inputs & outputs states. 0=Open, 1=Closed.	DIGITAL I/O 000000000 0000	Opto Inputs states (Left); Opto Outputs states (Right).
Press DISP key	Display mode showing actual drive running time.	TIME FROM PWR UP 0000000.01.43	HR.MIN.SEC format.
Press DISP key	Display mode showing continuous amps; PK amps rating; amps/volt scale of feedback, power base ID.	X.XA X.X APK X.XX A/V ID:XXX	
Press DISP key	Display mode showing which Group1 or 2 expansion boards are installed and recognized.	G1 NOT INSTALLED G2 NOT INSTALLED	In this case, no expansion boards are installed.
Press DISP key	Display mode showing motor shaft revolutions from the REV home set point.	POSITION COUNTER + 000.00000 REV	
Press DISP key	Display mode showing parameter table selected.	STOP TABLE LOCAL 0	
Press DISP key	Display mode showing software version and revision installed in the control.	SOFTWARE VERSION XXX.X.XX	
Press DISP key	Displays exit choice.	PRESS ENTER FOR DIAGNOSTIC EXIT	Press ENTER to exit diagnostic information.

**Table 5-3 Troubleshooting**

INDICATION	POSSIBLE CAUSE	CORRECTIVE ACTION
No Display	Lack of input voltage.	Check input power for proper voltage. Verify fuses are good (or breaker is not tripped). Verify Bus voltage is correct.
	Loose connections.	Check input power termination. Verify connection of operator keypad.
	Adjust display contrast.	See Adjust Display Contrast.
Auto Tune Encoder Test failed	Encoder miswired.	Correct wiring problems.
	Encoder coupling slipping, broken or misaligned.	Correct encoder to motor coupling.
	Excessive noise on encoder lines.	Check the position counter in the Diagnostic Information for jittering, which will confirm an encoder problem. Use recommended encoder cable. Check encoder connections including shields. Separate encoder leads from power wiring. Cross encoder wires and power leads at 90°. Electrically isolate encoder from motor. Wrong motor base speed or encoder counts values. Enter correct values. Motor coupled to load. Disconnect load then autotune.
Current Sense FLT	Open circuit between control board and current sensor.	Check connections between control board and current sensor.
	Defective current sensor.	Replace current sensor.
DC Bus High	Excessive dynamic braking DB power.	Increase the DECEL time. Add optional dynamic braking hardware.
	Dynamic brake wiring problem.	Check dynamic brake hardware wiring.
	Input voltage too high.	Verify proper AC line voltage. Use step down isolation transformer if needed. Use line reactor to minimize spikes.
DC Bus Low	Input voltage too low.	Disconnect dynamic brake hardware and repeat operation. Verify proper AC line voltage. Use step up isolation transformer if needed. Check power line disturbances (sags caused by start up of other equipment). Monitor power line fluctuations with date and time imprint to isolate power problem.
Encoder Loss	Encoder power supply failure.	Check encoder cable continuity. Check 5VDC at J2-4 and J2-5.
	Encoder coupling slipping, broken or misaligned	Correct or replace encoder to motor coupling.
	Excessive noise on encoder lines.	Check the position counter in the Diagnostic Information for jittering, which will confirm an encoder problem. Check encoder connections. Separate encoder leads from power wiring. Cross encoder wires and power leads at 90°. Electrically isolate encoder from motor.

**Table 5-3 Troubleshooting** Continued

INDICATION	POSSIBLE CAUSE	CORRECTIVE ACTION
External Trip	Motor ventilation insufficient.	Clean motor air intake and exhaust. Verify motor's internal fan is coupled securely. Check external blower for operation. Verify correct line power to external blower.
	Motor draws excessive current.	Check motor for overloading. Verify proper sizing of control and motor.
	No thermostat connected.	Connect thermostat. Verify connection of all external trip circuits used with thermostat. Disable thermostat input at J1B-16 (External Trip Input).
	Poor thermostat connections.	Check thermostat connections.
	External trip parameter incorrect.	Verify connection of external trip circuit at J1B-16. Set external trip parameter to "OFF" if no connection made at J1B-16.
Following ERR	Speed proportional gain set too low.	Following error tolerance band set too narrow. Increase Speed PROP Gain parameter value.
	Current limit set too low.	Increase Current Limit parameter value.
	ACCEL/DECEL time too short.	Increase ACCEL/DECEL parameter time
	Excessive load.	Verify proper sizing of control and motor.
GND FLT	Improper wiring.	Disconnect wiring between control and motor. Retry test.
	Wiring shorted in conduit. Motor winding shorted.	If GND FLT is cleared, reconnect motor leads and retry the test. Rewire as necessary. Repair motor. If GND FLT remains, contact Baldor.
INT Over-Temp	Ambient temperature too high.	Check air flow path is clean and free of debris. Relocate control to cooler operating area. Add cooling fans or air conditioner to control cabinet.
	Motor Overloaded.	Correct motor loading. Verify proper sizing of control and motor.
Invalid Base ID	Control board does not recognize power base.	Press "RESET" key on keypad. If fault remains, access Diagnostic Info and compare the reported ID# with Table 5-4. If different, call Baldor.
Logic Supply FLT	PSM malfunctioned.	Check PSM for defect. Check input power to PSM.
Lost User Data	Battery backed memory failure.	Parameter data was erased. Disconnect power to control and apply power (cycle power). Enter all parameters. Cycle power. If problem persists, contact Baldor.
Memory Error	Firmware fault occurred.	Press "RESET" key on keypad. If fault remains, call Baldor.
μP Reset	Power was cycled before Bus voltage reached 0VDC.	Press "RESET" key on keypad. Disconnect power and allow at least 5 minutes for Bus capacitors to discharge before applying power. If fault remains, call Baldor.

**Table 5-3 Troubleshooting** Continued

INDICATION	POSSIBLE CAUSE	CORRECTIVE ACTION
Motor has wrong response to Speed Command	Analog input common mode voltage may be excessive.	Connect control input source common to control common to minimize common mode voltage. Maximum common mode voltage at terminals J1A-4 and J1A-5 is $\pm 15$ VDC referenced to chassis common.
	Incorrect MIN or MAX speed settings.	Check Level 2 Output Limits block, MIN Output Speed and MAX Output Speed parameter values and adjust as needed.
	Analog offset trim is incorrectly set.	Re-run "Offset Trim" autotune test.
	Speed gain value is too large.	Reduce the Level 1 Vector Control block, Speed PROP Gain and Speed INT Gain parameter values.
Motor Shaft Oscillates back and forth	Incorrect encoder alignment direction.	Change the Feedback Align parameter in the Level 1 Vector Control block. If Reverse, set to Forward. If Forward, set to Reverse.
Motor Shaft rotates at low speed regardless of commanded speed	Incorrect encoder alignment direction.	Check encoder connections. Change the Feedback Align parameter in the Level 1 Vector Control block. If Reverse, set to Forward. If Forward, set to Reverse.
Motor Shaft rotates in wrong direction	Incorrect encoder wiring.	Reverse the A and $\bar{A}$ or B and $\bar{B}$ encoder wires at the J2 input to control and change encoder direction in the Feedback Align parameter in the Level 1 Vector Control block.
Motor Will Not Start	Not enough starting torque.	Increase Current Limit setting.
	Motor overloaded.	Check for proper motor loading. Check couplings for binding. Verify proper sizing of control and motor.
	Motor may be commanded to run below minimum speed setting.	Increase speed command or reduce minimum speed setting.
	Incorrect Command Select parameter.	Change Command Select parameter to match wiring at J1A.
	Incorrect speed command.	Verify control is receiving proper command signal at J1A.
Motor Will Not Reach Maximum Speed	Max Output Speed set too low.	Adjust Level 2 Output Limits block, MAX Output Speed parameter value.
	Motor overloaded.	Check for mechanical overload. If unloaded motor shaft does not rotate freely, check motor bearings.
	Improper speed command.	Verify control is set to proper operating mode to receive speed command. Verify control is receiving proper command signal at input terminals. Check velocity loop gains.
	Speed potentiometer failure.	Replace potentiometer.
Motor Will Not Stop Rotation	MIN Output Speed parameter set too high.	Adjust MIN Output Speed parameter value.
	Improper speed command.	Verify control is receiving proper command signal at input terminals. Verify control is set to receive speed command.
	Speed potentiometer failure.	Replace potentiometer.
	Analog input common mode voltage may be excessive.	Connect control input source common to control common to minimize common mode voltage. Maximum common mode voltage at terminals J1A-4 and J1A-5 is $\pm 15$ VDC referenced to chassis common.
	Analog offset trim set incorrectly.	Re-run "Offset Trim" autotune test. Adjust the Level 1 Input block, ANA CMD Offset parameter to obtain zero speed.

**Table 5-3 Troubleshooting** Continued

INDICATION	POSSIBLE CAUSE	CORRECTIVE ACTION
New Base ID	Software parameters are not initialized on newly installed control board.	Press "RESET" key on keypad to clear the fault condition. Reset parameter values to factory settings. Access diagnostics and compare power base ID number to list in Table 5-4 to ensure a match. Re-enter the Parameter Block Values you recorded in the User Settings at the end of this manual. Autotune the control.
No EXB Installed	Incorrect operating mode programmed.	Change Operating Mode in the Level 1 Input block to one that does not require the expansion board.
	Need expansion board.	Install the correct expansion board for selected operating mode.
Over Current FLT	Current Limit parameter set lower than drive rating.	Increase PK Current Limit parameter in the Level 2 Output Limits block, not to exceed drive rating.
	ACCEL/DECEL time too short.	Increase ACCEL/DEC parameters in the Level 1 ACCEL/DECEL Rate block.
	Encoder coupling slipping, broken or misaligned.	Correct or replace encoder to motor coupling.
	Encoder bearing failure.	Replace and align encoder.
	Excessive noise on encoder lines.	Check the position counter in the Diagnostic Information for jittering, which will confirm an encoder problem. Check encoder connections. Separate encoder leads from power wiring. Cross encoder wires and power leads at 90°. Electrically isolate encoder from motor.
	Electrical noise from external DC coils.	Install reverse biased diodes across all external DC relay coils as shown in the Opto Output circuit examples of this manual. See Electrical Noise Considerations in Section 5 of this manual.
	Electrical noise from external AC coils.	Install RC snubbers on all external AC coils. See Electrical Noise Considerations in Section 5 of this manual.
	Excessive load.	Reduce the motor load. Verify proper sizing of control and motor.
Overload - 1.5 Sec FLT	Peak output current exceeded 1.5 second rating.	Check PK Current Limit parameter in the Level 2 Output Limits block. Change Overload parameter In the Level 2 Protection block from Trip to Foldback. Increase ACCEL time. Reduce motor load. Verify proper sizing of control and motor.
	Encoder coupling slipping, broken or misaligned.	Correct or replace encoder to motor coupling.
	Encoder bearing failure.	Replace and align encoder.
Overload - 7 Sec FLT	Peak output current exceeded 7 second rating.	Check PK Current Limit parameter in the Level 2 Output Limits block. Change Overload parameter In the Level 2 Protection block from Trip to Foldback. Increase ACCEL/DECEL times. Reduce motor load. Verify proper sizing of control and motor.
	Encoder coupling slipping, broken or misaligned.	Correct or replace encoder to motor coupling.
	Encoder bearing failure.	Replace and align encoder.
Over Speed	Motor exceeded 110% of MAX Speed parameter value.	Check the Level 2 Output Limits block, Max Output Speed. Increase the Level 1 Vector Control block, Speed PROP Gain.



**Table 5-3 Troubleshooting** Continued

INDICATION	POSSIBLE CAUSE	CORRECTIVE ACTION
Power Module	Power supply failure.	Press "RESET" key on keypad. If fault remains, call Baldor.
PWR Base FLT	Improper ground	Be sure the PSM has separate ground wire to earth ground. Panel grounding or conduit connections is not sufficient.
	Excessive current usage.	Disconnect motor leads from control and retry test. If fault remains, call Baldor.
	Encoder coupling slipping, broken or misaligned.	Correct or replace encoder to motor coupling.
	Encoder bearing failure.	Replace and align encoder.
	Excessive noise on encoder lines.	Check encoder connections. Separate encoder leads from power wiring. Cross encoder wires and power leads at 90°. Electrically isolate encoder from motor.
	Electrical noise from external DC coils.	Install reverse biased diodes across all external DC relay coils as shown in the Opto Output circuit examples of this manual. See Electrical Noise Considerations in Section 5 of this manual.
	Electrical noise from external AC coils.	Install RC snubbers on all external AC coils. See Electrical Noise Considerations in Section 5 of this manual.
	Excessive load.	Correct motor load. Verify proper sizing of control and motor.
	Excessive power in dynamic brake circuit.	Increase decel time. Increase optional dynamic braking hardware capacity.
Resolver Loss	Resolver defect.	Check resolver to motor coupling (align or replace if needed). Verify correct wiring. Refer to the Resolver to Digital expansion board manual. Electrically isolate resolver from motor.
Torque Prove FLT	Unbalanced current in 3 motor phases.	Check continuity from control to motor windings and verify motor connections.
Unknown Fault	Fault occurred but cleared before its source could be identified.	Check AC line for high frequency noise. Check input switch connections and switching noise.
User Fault Text	Fault detected by custom software.	Refer to custom software fault list.

**Table 5-4 25M-PO Power Base ID**

230 VAC Control Catalog Numbers	Power Base ID No.	460 VAC Control Catalog Numbers	Power Base ID No.
ZD25M2A05-P0	16	ZD25M4A02-P0	1E
ZD25M2A10-P0	17	ZD25M4A07-P0	20
ZD25M2A15-P0	18	ZD25M4A15-P0	21
ZD25M2A25-P0	19	ZD25M4A25-P0	26
ZD25M2A35-P0	1A	ZD25M4A35-P0	22
ZD25M2A45-P0	1B	ZD25M4A45-P0	23
ZD25M2A60-P0	1C	ZD25M4A60-P0	24
ZD25M2A90-P0	1D	ZD25M4A90-P0	25

**Table 5-5 25M-TR Power Base ID**

115 VAC Control Catalog Numbers	Power Base ID No.	230 VAC Control Catalog Numbers	Power Base ID No.
ZD25M1A02-TR	49	ZD25M2A02-TR	09
ZD25M1A05-TR	4B	ZD25M2A05-TR	0B
ZD25M1A07-TR	CB	ZD25M2A07-TR	8B

Note: The Power Base ID number of a control is displayed in a Diagnostic Information screen.

---

**Electrical Noise Considerations** All electronic devices are vulnerable to significant electronic interference signals (commonly called “Electrical Noise”). At the lowest level, noise can cause intermittent operating errors or faults. From a circuit standpoint, 5 or 10 millivolts of noise may cause detrimental operation. For example, analog speed and torque inputs are often scaled at 5 to 10 VDC maximum with a typical resolution of one part in 1,000. Thus, noise of only 5 mV represents a substantial error.

At the extreme level, significant noise can cause damage to the drive. Therefore, it is advisable to prevent noise generation and to follow wiring practices that prevent noise generated by other devices from reaching sensitive circuits. In a control, such circuits include inputs for speed, torque, control logic, and speed and position feedback, plus outputs to some indicators and computers.

**Relay and Contactor Coils** Among the most common sources of noise is the coil of a contactor or a relay. When these highly inductive coil circuits are opened, transient conditions often generate spikes of several hundred volts in the control circuit. These spikes can induce several volts of noise in an adjacent wire that runs parallel to a control-circuit wire.

Figure 5-1 illustrates noise suppression for AC and DC operated coils.

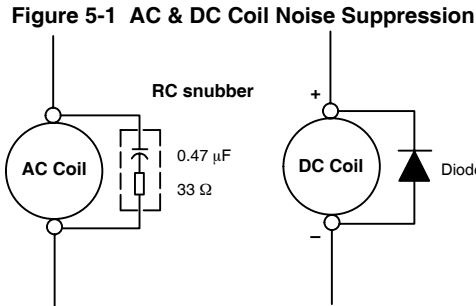

#### Wires between Controls and Motors

Output leads from a typical 460 VAC drive controller contain rapid voltage rises created by power semiconductors switching 650V in less than a microsecond, 1,000 to 10,000 times a second. These noise signals can couple into sensitive drive circuits. If shielded pair cable is used, the coupling is reduced by nearly 90% compared to unshielded cable.

Even input AC power lines contain noise and can induce noise in adjacent wires. In some cases, line reactors may be required.

To prevent induced transient noise in signal wires, all motor leads and AC power lines should be contained in rigid metal conduit, or flexible conduit. Do not place line conductors and load conductors in same conduit. Use one conduit for 3 phase input wires and another conduit for the motor leads. The conduits should be grounded to form a shield to contain the electrical noise within the conduit path. Signal wires - even ones in shielded cable should never be placed in the conduit with motor power wires.

---

## Electrical Noise Considerations Continued

### Special Drive Situations

For severe noise situations, it may be necessary to reduce transient voltages in the wires to the motor by adding load reactors. Load reactors are installed between the control and motor.

Reactors are typically 3% reactance and are designed for the frequencies encountered in PWM drives. For maximum benefit, the reactors should be mounted in the drive enclosure with short leads between the control and the reactors.

### Control Enclosures

Motor controls mounted in a grounded enclosure should also be connected to earth ground with a separate conductor to ensure best ground connection. Often grounding the control to the grounded metallic enclosure is not sufficient. Usually painted surfaces and seals prevent solid metallic contact between the control and the panel enclosure. Likewise, conduit should never be used as a ground conductor for motor power wires or signal conductors.

### Special Motor Considerations

Motor frames must also be grounded. As with control enclosures, motors must be grounded directly to the control and plant ground with as short a ground wire as possible. Capacitive coupling within the motor windings produces transient voltages between the motor frame and ground. The severity of these voltages increases with the length of the ground wire. Installations with the motor and control mounted on a common frame, and with heavy ground wires less than 10 ft. long, rarely have a problem caused by these motor-generated transient voltages.

Sometimes motor frame transient voltages are capacitively coupled to feedback devices mounted on the motor shaft. To prevent this problem, add electrical isolation between the motor and the feedback device. The most simple isolation method, shown in Figure 5-2, has two parts: 1) A plate of electrical insulating material placed between the motor mounting surface and the feedback device. 2) An insulating coupling between motor shaft and the shaft of the feedback device.

**Figure 5-2 Isolated Mounting Method**

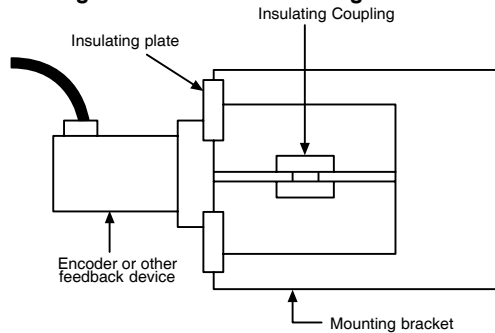

### Analog Signal Wires

Analog signals generally originate from speed and torque controls, plus DC tachometers and process controllers. Reliability is often improved by the following noise reduction techniques:

- Use twisted-pair shielded wires with the shield grounded at the drive end only.
- Route analog signal wires away from power or control wires (all other wiring types).
- Cross power and control wires at right angles (90°) to minimize inductive noise coupling.

## Section 6

### Manually Tuning the Series 25M Control

---

**Manually Tuning the Control** In some applications the drive cannot be accurately autotuned. In these cases, it is necessary to calculate the values needed to tune the drive and manually enter these calculated parameter values.

**Motor Mag Amps Parameter** This parameter is located in the Level 2, Motor Data Block. This parameter is normally entered using the nameplate data (motor no load amps) or auto-tuned. If no other data is available, set Motor Mag Amps parameter to about 40% of the motor rated current stated on the nameplate.

The following procedure should be used for setting the Motor Mag Amps parameter when the load cannot be uncoupled from the motor shaft:

1. Adjust the Motor Mag Amps Parameter to 40% of the motor nameplate full load current rating.
2. Give the controller a speed command input of 80% of the Base Speed on motor nameplate.
3. Select motor voltage on keypad display by pressing the DISP key until the motor voltage value is displayed.
4. Observe the motor voltage. Ideally, it should read 80% of motor nameplate voltage. By raising the Motor Mag Amps parameter value, the motor voltage will raise proportionally. Continuing to raise the Motor Mag Amps parameter value will eventually saturate the motor voltage. By lowering the Motor Mag Amps parameter value, the motor voltage will lower proportionally.
5. While the motor is running, adjust the Motor Mag Amps parameter until the display indicates the proper voltage (80% of motor rated).

**Slip Frequency Parameter** This parameter is located in the Level 1, Vector Control Block. The slip frequency may be calculated from nameplate data or auto tuned.

$$F_{\text{slip}} = \text{Rated Freq} - \left[ \frac{(\text{Rated RPM} \times \text{Number of Motor Poles})}{120} \right] \text{ OR}$$

$$F_{\text{slip}} = \text{Rated Freq} - \left[ \left( \frac{\text{Base Speed}}{\text{Sync Speed}} \right) (\text{Rated Freq}) \right]$$

**Current Prop Gain Parameter** This parameter is located in the Level 1, Vector Control Block. The Current Prop Gain parameter is normally autotuned when motor inductance is not known. Where autotuning can't be used, the proper manual setting for the proportional gain can be calculated by:

$$\text{Current PROP Gain} = \frac{[740 \times L \times (A/V)]}{\text{VAC}}$$

Where:

L = Line to neutral leakage inductance of the motor in mH

VAC = Nominal line Volts

A/V = The Amps/Volt scaling of the current feedback

Motor line to neutral leakage inductance can be obtained either from the motor manufacturer or by measuring the line-to-line inductance and dividing by two.

The A/V scaling for the controller can be found in the diagnostic information located in the DISPLAY MODE.

For most applications setting the Current Prop Gain parameter to a value of 60 will yield adequate performance.

---

### **Current Int Gain Parameter**

The Current Int Gain parameter located in the Level 1 Vector Control Block is factory preset at 150 Hz. This setting is suitable for essentially all systems. **DO NOT CHANGE WITHOUT FACTORY APPROVAL.**

### **Speed Prop Gain Parameter**

The Speed Prop Gain parameter located in the Level 1 Vector Control Block is factory set to 10. This gain may be increased or decreased to suit the application. Increasing the Speed Prop Gain parameter will result in faster response, excessive proportional gain will cause overshoot and ringing. Decreasing the Speed Prop Gain parameter will cause slower response and decrease overshoot and ringing caused by excessive proportional gain.

### **Speed Int Gain Parameter**

The Speed Int Gain parameter located in the Level 1 Vector Control Block is set to 3 Hz and may be set at any value from zero to 9.99 Hz. See also, PI Controller later in this section.

Setting the Speed Int Gain parameter to 0Hz removes integral compensation that results in a proportional rate loop. This selection is ideal for systems where overshoot must be avoided and substantial stiffness (ability of the controller to maintain commanded speed despite varying torque loads) isn't required.

Increasing values of the Speed Int Gain parameter increases the low frequency gain and stiffness of the controller, an excessive integral gain setting will cause overshoot for transient speed commands and may lead to oscillation. If the Speed Prop Gain parameter and the Speed Int Gain parameter are set too high, an overshoot condition can also occur.

To manually tune the control, the following procedure is used:

1. Set the speed Int Gain parameter = 0 (remove integral gain).
2. Increase the Speed Prop Gain parameter setting until adequate response to step speed commands is attained.
3. Increase the Speed Int Gain parameter setting to increase the stiffness of the drive, or ability to maintain speed with dynamic load changes.

Note: It is convenient to monitor speed step response with a strip chart recorder or storage oscilloscope connected to J1-6 or -7 with Level 1, Output Block Analog Out #1 or #2 set to ABS SPEED, 0 VDC = zero speed. See Section 3 for a discussion of analog outputs.

---

## PI Controller

Both the current and rate control loops are of the Proportional plus Integral type. If "E" is defined to be the error signal,

$$E = \text{Command} - \text{Feedback}$$

then the PI controller operated on "E" as

$$\text{Output} = (K_p * E) + (K_i \int E dt)$$

where  $K_p$  is the proportional gain of the system and  $K_i$  is the integral gain of the system.

The transfer function (output /E) of the controller using 1/s (Laplace Operator) to denote the integral,

$$\text{Output}/E = K_p + K_i / s = K_p (s + K_i/K_p) /s.$$

The second equation shows that the ratio of  $K_i/K_p$  is a frequency in radians/sec. In the Baldor AC Vector Control, the integral gain has been redefined to be,

$$K_i = (K_i / K_p) / (2\pi) \text{ Hz,}$$

and the transfer function is,

$$\text{Output}/E = K_p (s + 2\pi K_i) / s.$$

This sets the integral gain as a frequency in Hz. As a rule of thumb, set this frequency about 1/10 of the bandwidth of the control loop.

The proportional gain sets the open loop gain of the system, the bandwidth (speed of response) of the system. If the system is excessively noisy, it is most likely due to the proportional gain being set too high.



## Section 7 Specifications and Product Data

---

### Identification

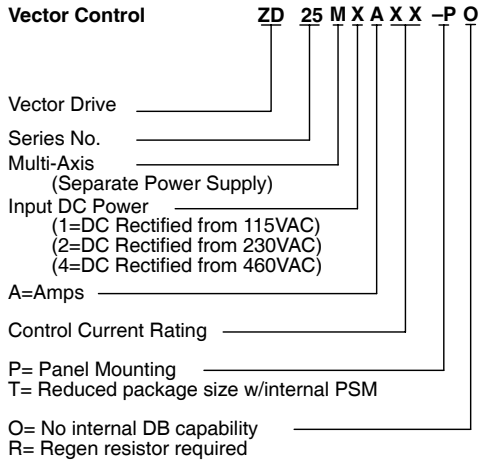

### Identification

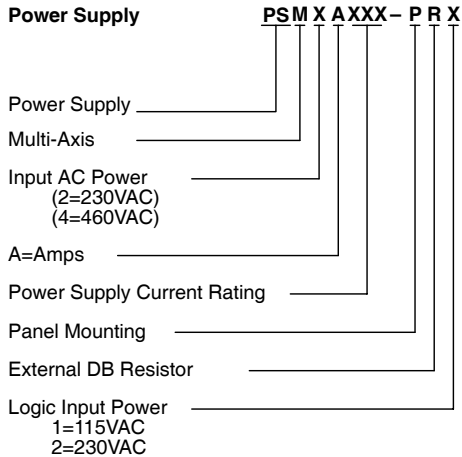



### 25M-TR Control Specifications: (115VAC)

Description	Unit	ZD25M1A02-TR	ZD25M1A05-TR	ZD25M1A07-TR
Nominal Input Voltage (Range)	VAC	115 (97-125) 1 $\phi$		
Input Frequency	Hz	50/60 $\pm$ 5%		
Nominal Output Bus Voltage (Range)	VDC	163 (100–210)		
Nominal Output Bus Current	A <sub>RMS</sub>	2.5	5.0	7.5
Peak Output Bus Current ( $\pm$ 10%); 2.5s $\pm$ .5s	A <sub>RMS</sub>	5.0	10.0	15.0
Nominal Output Power	kW	0.5	1.0	1.4
Efficiency	%	>95		
Minimum Load Inductance	$\mu$ H	400		
Nominal Switching Frequency	kHz	8.5 *		
Package Size		A1	AC	AC
Mounting	–	Panel		
Weight	lb(kg)	4.83(2.19)		
Operating Altitude	ft(M)	To 3300ft (1000M). Above 3300 ft, derate 11% per 1000ft (300M).		
Operating Shock	G	1G		
Operating Vibration	G	1.0G (10-60Hz)		
Operating Temperature Range	$^{\circ}$ C	5 to 40 $^{\circ}$ C.		
Maximum Operating Temperature	$^{\circ}$ C	40 $^{\circ}$ C Maximum.		
Storage Temperature Range	$^{\circ}$ C	–25 to +70 $^{\circ}$ C		
Speed Command Potentiometer		5k $\Omega$ or 10k $\Omega$ , 0.5watt		

All values at ambient temperature of 25 $^{\circ}$ C unless otherwise stated.

### 25M-TR Control Specifications: (230VAC)

Description	Unit	ZD25M2A02-TR	ZD25M2A05-TR	ZD25M2A07-TR
Nominal Input Voltage (Range)	VAC	230 (220-250) 1 $\phi$		
Input Frequency	Hz	50/60 $\pm$ 5%		
Nominal Output Bus Voltage (Range)	VDC	325 (200–420)		
Nominal Output Bus Current	A <sub>RMS</sub>	2.5	5	7.5
Peak Output Bus Current ( $\pm$ 10%); 2.5s $\pm$ .5s	A <sub>RMS</sub>	5.0	10.0	15.0
Nominal Output Power	kW	1.01	2.17	2.99
Efficiency	%	>95		
Minimum Load Inductance	$\mu$ H	400		
Nominal Switching Frequency	kHz	8.5 *		
Package Size		A1	AC	AC
Mounting	–	Panel		
Weight	lb(kg)	4.83(2.19)		
Operating Altitude	ft(M)	To 3300ft (1000M). Above 3300 ft, derate 11% per 1000ft (300M).		
Operating Shock	G	1G		
Operating Vibration	G	1.0G (10-60Hz)		
Operating Temperature Range	$^{\circ}$ C	5 to 40 $^{\circ}$ C		
Maximum Operating Temperature	$^{\circ}$ C	40 $^{\circ}$ C Maximum		
Storage Temperature Range	$^{\circ}$ C	–25 to +70 $^{\circ}$ C		
Speed Command Potentiometer		5k $\Omega$ or 10k $\Omega$ , 0.5watt		

All values at ambient temperature of 25 $^{\circ}$ C unless otherwise stated.

\* Nominal switching frequency is adjustable to 16kHz with linear derating (between 8 - 16kHz) by 30% at 16kHz.

## 25M-PO Control Specifications and Ratings: (230VAC)

Description	Unit	ZD25M 2AXX-X								
		05-P	10-P	15-P	25-P	35-P	45-P	60-P	90-P	
Nominal Input Bus Voltage	VDC	325								
Input Logic & Fan Power	VDC	+24 (+20% -15%)								
	ADC	1.6								
Nominal Output Bus Voltage (Range)	VDC	325 (200-420)								
Nominal Bus Current **	A <sub>RMS</sub>	5	10	15	25	35	45	60	90	
Peak Output Bus Current (±10%); 1.5s ±.5s	A <sub>RMS</sub>	10	20	30	50	70	90	120	180	
Nominal Output Power	kW	1.1	2.2	3.4	5.7	7.9	10.2	13.7	20.5	
Efficiency	%	>97								
Minimum Load Inductance	µH	200								
Nominal Switching Frequency **	kHz	8.0								
Mounting *	-	Panel or through wall								
Package Size		B	B	B	B	B	C	D	D	
Weight	lb(kg)	21(9.5)	21(9.5)	21(9.5)	21(9.5)	21(9.5)	26(11.8)	51(23.1)	51(23.1)	
Operating Altitude	ft.(M)	To 3300ft (1000M). Above 3300 ft, derate 2% per 1000ft (300M).								
Operating Shock	G	1G								
Operating Vibration	G	0.5G (10-60Hz)								
Operating Temperature Range	°C	0 to 40°C. Derate output by 2% per °C above 45°C. (60°C Max.)								
Maximum Operating Temperature	°C	60°C Maximum with derating.								
Storage Temperature Range	°C	-25 to +70°C								
Speed Command Potentiometer		5kΩ or 10kΩ, 0.5watt								

## Control Specifications and Ratings: (460VAC)

Description	Unit	ZD25M 4AXX-X								
		02-P	07-P	15-P	25-P	35-P	45-P	60-P	90-P	
Nominal Input Bus Voltage	VDC	650								
Input Logic & Fan Power	VDC	+24 (+20% -15%)								
	Size	B	B	B	B	B	C	D	D	
	ADC	1.7	1.7	1.7	1.7	1.7	1.7	2.9	2.9	
Nominal Output Bus Voltage (Range)	VDC	650 (400-840)								
Nominal Output Bus Current **	A <sub>RMS</sub>	2	7	15	25	35	45	60	90	
Peak Output Bus Current (±10%); 1.5s ±.5s	A <sub>RMS</sub>	4	14	30	50	70	90	120	180	
Nominal Output Power	kW	0.9	3.2	6.9	11.6	16.2	20.8	27.8	41.7	
Efficiency	%	>97								
Minimum Load Inductance	µH	200								
Nominal Switching Frequency **	kHz	8.0								
Mounting *	-	Panel or through wall								
Package Size		B	B	B	B	C	D	D	D	
Weight	lb(kg)	21(9.5)	21(9.5)	21(9.5)	21(9.5)	26(11.8)	51(23.1)	51(23.1)	51(23.1)	
Operating Altitude	ft.(M)	To 3300ft (1000M). Above 3300 ft, derate 2% per 1000ft (300M).								
Operating Shock	G	1G								
Operating Vibration	G	0.5G (10-60Hz)								
Operating Temperature Range	°C	0 to 40°C. Derate output by 2% per °C above 45°C. (60°C Max.)								
Maximum Operating Temperature	°C	60°C Maximum with derating.								
Storage Temperature Range	°C	-25 to +70°C								
Speed Command Potentiometer		5kΩ or 10kΩ, 0.5watt								

All values at ambient temperature of 25°C unless otherwise stated.

\* Thru wall mounting is possible. Refer to mounting dimensions.

\*\* Nominal Bus Output Current rating from the 1-8kHz PWM switching frequency.

PWM switching frequency is adjustable to 16kHz. Above 8kHz, derate Bus Current at a linear rate to 30% reduction at 16kHz.

**PSM-PR Power Supply Specifications:**

Description	Unit	PSM2AXXX-X		PSM4AXXX-X		
		060-PR1	100-PR1	030-PR1	050-PR1	100-PR1
Input Bus Voltage – Nominal (Range)	VAC	230 3 $\phi$ (180-264; 60Hz 180-230; 50Hz)		460 3 $\phi$ (400-528; 60Hz 340-457; 50Hz)		
Input Frequency	Hz	50 / 60 $\pm$ 5%				
Nominal Output Bus Voltage	VDC	325 (200–420)		650 (400–840)		
Nominal Output Bus Current	A <sub>RMS</sub>	60	100	30	50	100
Peak Output Bus Current	A <sub>RMS</sub>	120	200	60	100	200
Input Logic Voltage – Nominal (Range)	VAC	115 (+6% –10%; 60Hz only 1 phase)				
Input Logic Current – Nominal (Range) *	AMP	2.4A (@115)				
Output Logic	VDC	+24 (+20% – 15%)				
Output Logic	ADC	8.0				
Mounting	–	Panel or Thru Wall				
Package Size		B	B	B	B	D
Weight	lb(kg)	33(15)	33(15)	33(15)	33(15)	63(28.6)

All values at 25°C unless otherwise stated.

\* Maximum surge current <100msec = 6A (230V); 12A (115V)

Description	Unit	PSM2AXXX-X		PSM4AXXX-X		
		060-PR2	100-PR2	030-PR2	050-PR2	100-PR2
Input Bus Voltage – Nominal (Range)	VAC	230 3 $\phi$ (180-264; 60Hz 180-230; 50Hz)		460 3 $\phi$ (400-528; 60Hz 340-457; 50Hz)		
Input Frequency	Hz	50 / 60 $\pm$ 5%				
Nominal Output Bus Voltage	VDC	325 (200–420)		650 (400–840)		
Nominal Output Bus Current	A <sub>RMS</sub>	60	100	30	50	100
Peak Output Bus Current	A <sub>RMS</sub>	120	200	60	100	200
Input Logic Voltage – Nominal (Range)	VAC	230 (+6% –10%; 50/60Hz 1 phase)				
Input Logic Current – Nominal (Range) *	AMP	1.2A (@230)				
Maximum Input Surge Current (for 100ms)	A <sub>RMS</sub>	6				
Output Logic	VDC	+24 (+20% – 15%)				
Output Logic	ADC	8.0				
Mounting	–	Panel or Through Wall				
Package Size		B	B	B	B	D
Weight	lb(kg)	33(15)	33(15)	33(15)	33(15)	63(28.6)

All values at 25°C unless otherwise stated.

\* Maximum surge current<100msec = 6A (230V); 12A (115V)

---

**Keypad Display:**

Display	Backlit LCD Alphanumeric 2 Lines x 16 Characters
Keys	12 key membrane with tactile response
Functions	Output status monitoring Digital speed control Parameter setting and display Diagnostic information display Fault log display Motor run and jog Local/Remote toggle
LED Indicators	Forward run command Reverse run command Stop command Jog active
Remote Mount	100 feet max from control

**Control Signal Levels:**

Description	Unit	ZD25M-PO and ZD25M-TR
Command Input	VDC	0–10VDC, 0–5VDC ±10VDC or (4–20mA)
Command Signal Resolution	bits	9 bits + sign
Feedback System	–	Encoder
Feedback Resolution	ppr	1024 (Standard)
Buffered Encoder Output	ppr	1024
Buffered Encoder Output	–	RS422 (5V @ 500kHz maximum)

**Differential Analog Input::**

Description	Unit	ZD25M-PO and ZD25M-TR
Common Mode Rejection	db	40 db
Full Scale Range	VDC	±5VDC, ±10VDC, 4-20 mA
Resolution	bits	9 bits + sign
Update rate	sec	500µsec

**Other Analog Input:**

Description	Unit	ZD25M-PO and ZD25M-TR
Full Scale Range	VDC	0 - 10 VDC
Resolution	bits	9 bits + sign
Update Rate	sec	500µsec

---

### Analog Outputs:

Description	Unit	ZD25M-PO and ZD25M-TR
Analog Outputs		2 Assignable
Full Scale Range	VDC	0-10 VDC or $\pm 10$ VDC (depends on output condition selected)
Source Current	mA	1 mA maximum
Resolution	bits	8 bits
Update Rate	msec	2 msec

### Digital Inputs:

Description	Unit	ZD25M-PO and ZD25M-TR
Opto-isolated Logic Inputs		9 Assignable
Rated Voltage	VDC	10 - 30 VDC (closed contacts std)
Input Impedance	k $\Omega$	6.8 K Ohms
Leakage Current	$\mu$ A	10 $\mu$ A maximum
Update Rate	msec	16 msec

### Digital Outputs:

Description	Unit	ZD25M-PO and ZD25M-TR
Opto-isolated Logic Outputs		4 Assignable
ON Current Sink	mA	50 mA Max
ON Voltage Drop	VDC	2 VDC Max
Update Rate	msec	31 msec

### Diagnostic Indications:

Current Sense Fault	Regeneration (db) Overload
Instantaneous Over Current	Under Voltage
Invalid Power Base ID	Ready
Line Power Loss	Parameter Loss
Microprocessor Failure	Overload
Over temperature (Motor or Control)	Overvoltage
Over speed	Torque Proving
Following Error	Co-Processor

Note: All specifications are subject to change without notice.

---

**Terminal Tightening Torque Specifications****Table 7-1 Tightening Torque Specifications – 25M-PO Controls**

25M-PO Control	Tightening Torque					
	U, V and W		GND		+VCC, -VCC, GND	
	Lb-in	Nm	Lb-in	Nm	Lb-in	Nm
Size B	20-27	2.3-3.0	35-46	4.0-5.0	35-46	4.0-5.0
Size C	20-27	2.3-3.0	35-46	4.0-5.0	35-46	4.0-5.0
Size D	22-27	2.5-3.0	22-27	2.5-3.0	52	6.0

**Table 7-2 Tightening Torque Specifications – PSM-PR**

PSM-PR	Tightening Torque							
	GND		L1, L2, L3		R1, R2		+VCC, -VCC, GND	
	Lb-in	Nm	Lb-in	Nm	Lb-in	Nm	Lb-in	Nm
Size B	35-46	4.0-5.0	20-27	2.3-3.0	20-27	2.3-3.0	35-46	4.0-5.0
Size D	22-27	2.5-3.0	22-27	2.5-3.0	10.6-12.3	1.2-1.4	52	6.0

## DB Resistor Selection

### RG Mounting Information

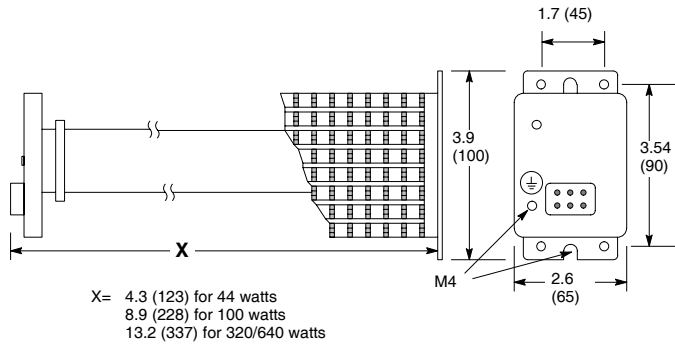

### RGA Mounting Information

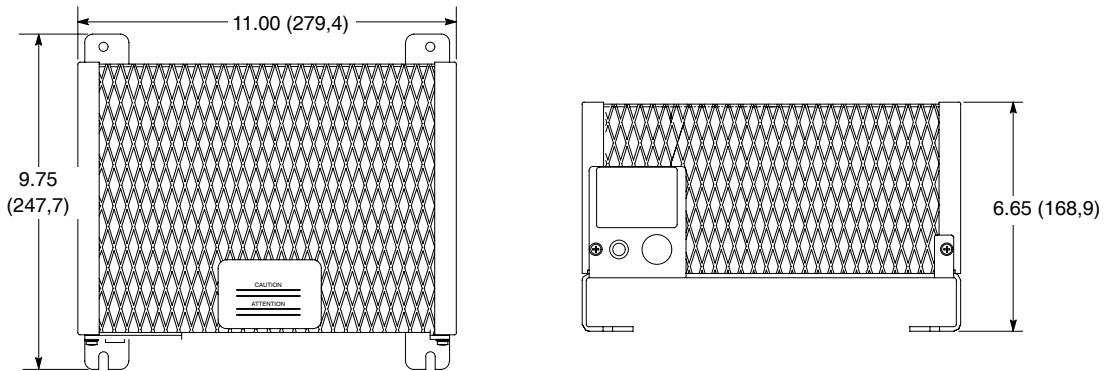

Table 7-3 DB Resistor (25M-TR)

Control Catalog No.	Input Voltage (VAC)	Continuous Dynamic Braking Watts	Catalog No.
ZD25M1A02-TR	115	44	RG27
ZD25M1A05-TR	115	44	RG27
ZD25M1A07-TR	115	44	RG27
ZD25M2A02-TR	230	44	RG56
ZD25M2A05-TR	230	44	RG56
ZD25M2A07-TR	230	44	RG56

**DB Resistor Selection** – Continued

**Table 7-4 DB Resistor (PSM-PR)**

Power Supply Catalog No.	320 Continuous Watts			640 Continuous Watts			1200 Continuous Watts		
	Part No.	Max. Peak Watts	Peak Watts Max. Duty%	Part No.	Max. Peak Watts	Peak Watts Max. Duty%	Part No.	Max. Peak Watts	Peak Watts Max. Duty%
PSM2A060-PR2	RG6.8	15,050	2	RGA606*	17,000	3.5	RGA1210	10,240	11.7
PSM2A100-PR2				RG4.1	25,000	2.5	RGA1204	25,600	5.0
PSM2A060-PR1	RG6.8	15,050	2	RGA606*	17,000	3.5	RGA1210	10,240	11.7
PSM2A100-PR1				RG4.1	25,000	2.5	RGA1204	25,600	5.0
PSM4A030-PR2				RG23	18,000	3.5	RGA1224	17,600	6.8
PSM4A050-PR2				RG16	26,400	2.5	RGA1220	21,000	5.7
PSM4A100-PR2							RGA1210	42,250	2.8
PSM4A030-PR1				RG23	18,000	3.5	RGA1224	17,600	6.8
PSM4A050-PR1				RG16	26,400	2.5	RGA1220	21,000	5.7
PSM4A100-PR1							RGA1210	42,250	2.8

\* 600 watt resistors.

 Not available.

**Table 7-4 DB Resistor (PSM-PR)** – Continued

Power Supply Catalog No.	2400 Continuous Watts			4800 Continuous Watts		
	Part No.	Max. Peak Watts	Peak Watts Max. Duty%	Part No.	Max. Peak Watts	Peak Watts Max. Duty%
PSM2A060-PR2	RGA2410	10,240	23.0	RGA4810	10,240	46.8
PSM2A100-PR2	RGA2404	25,600	9.3	RGA4804	25,600	18.7
PSM2A060-PR1	RGA2410	10,240	23.0	RGA4810	10,240	23.4
PSM2A100-PR1	RGA2404	25,600	9.3	RGA4804	25,600	18.7
PSM4A030-PR2	RGA2424	17,600	13.6	RGA4824	17,600	27.2
PSM4A050-PR2	RGA2420	21,000	11.4	RGA4820	21,000	22.8
PSM4A100-PR2	RGA2410	42,250	5.7	RGA4810	42,250	11.3
PSM4A030-PR1	RGA2424	17,600	13.6	RGA4824	17,600	27.2
PSM4A050-PR1	RGA2420	21,000	11.4	RGA4820	21,000	22.8
PSM4A100-PR1	RGA2410	42,250	5.7	RGA4810	42,250	11.3



## 25M-TR Dimensions

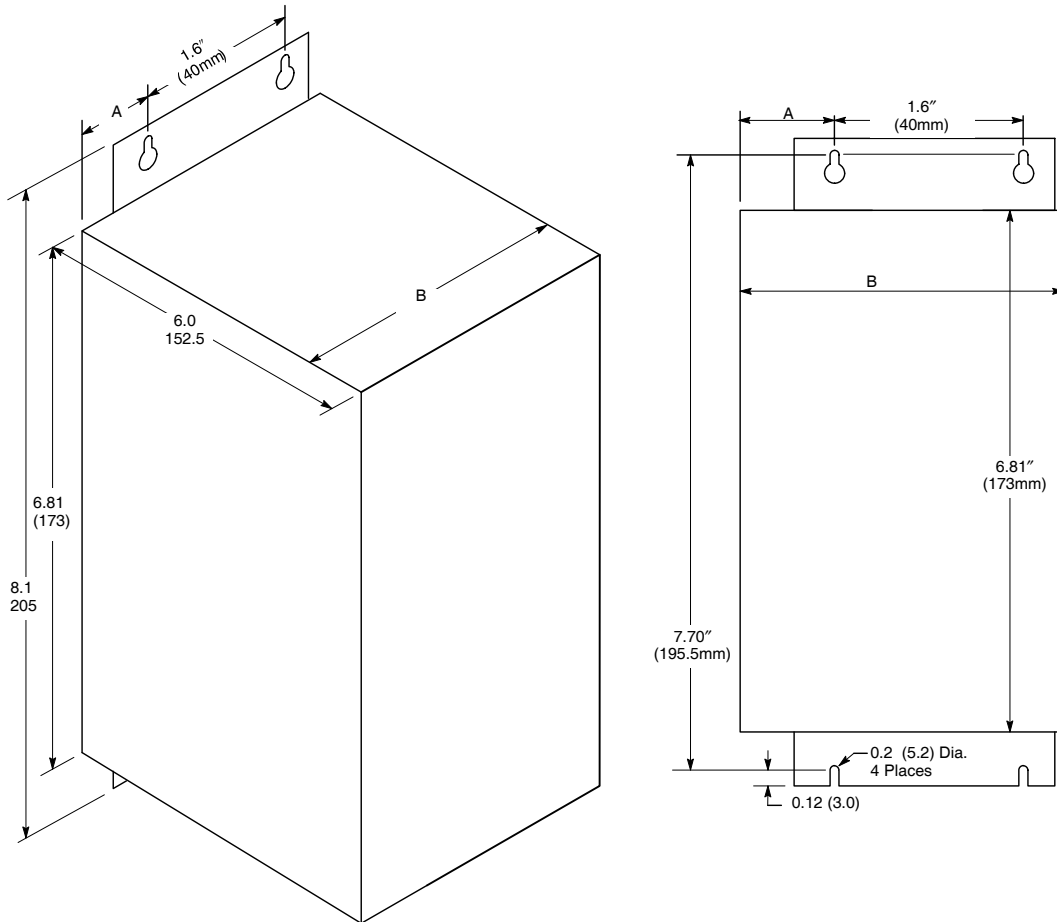

Dimension	Package Size	
	A1	AC
A	0.6 (15)	0.9 (23)
B	3.3 (84)	4.3 (109)

## 25M-PO Dimensions

### Size B Dimensions & Mounting

Reference this edge to measure distance to mount next enclosure.

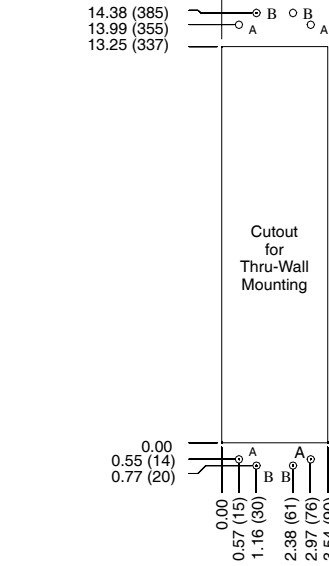

Holes coded "A" and "B".  
Mounting hole locations for surface mounting. Recommended hardware 1/4"-20 or M6 thru hole .25"(6.4mm) dia.

Thru Wall Dimensions

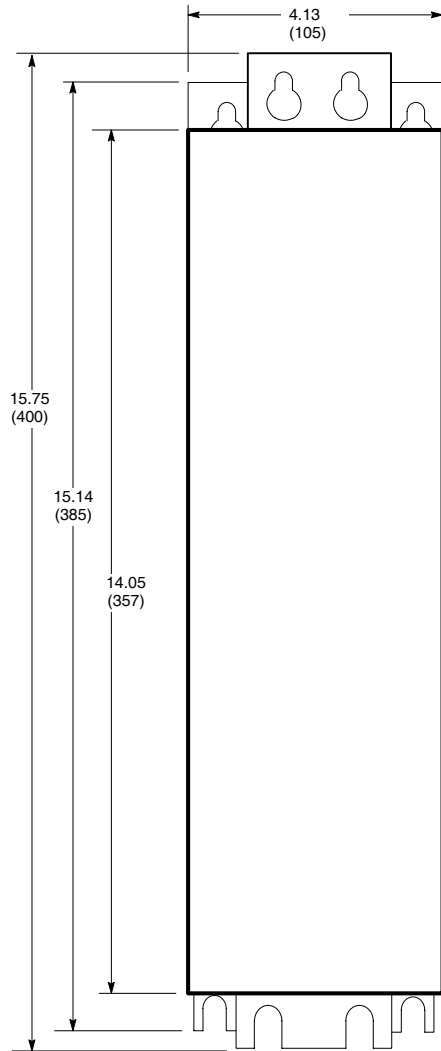
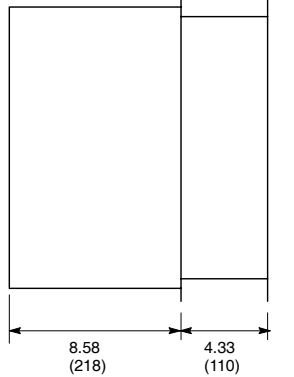

**25M-PO Dimensions** Continued  
**Size C Dimensions & Mounting**

Reference this edge to measure distance to mount next enclosure.

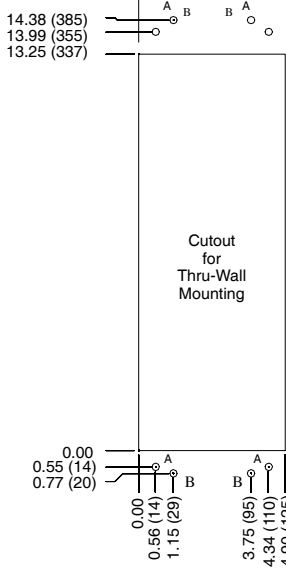

Holes coded "A" and "B".  
 Mounting hole locations for surface mounting. Recommended hardware 1/4"-20 or M6 thru hole .25"(6.4mm)dia.

Thru Wall Dimensions

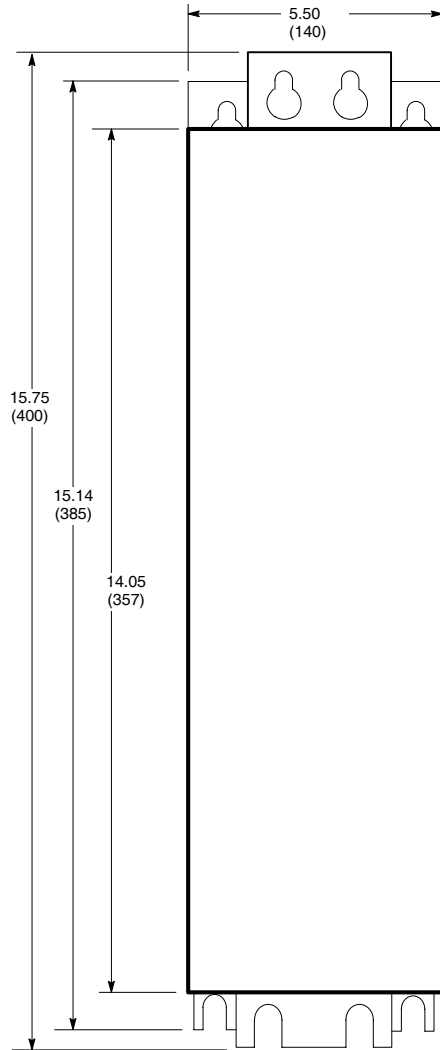
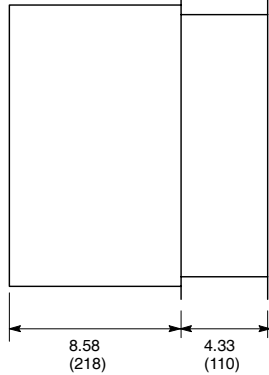

**25M-PO Dimensions** Continued

**Size D Dimensions & Mounting**

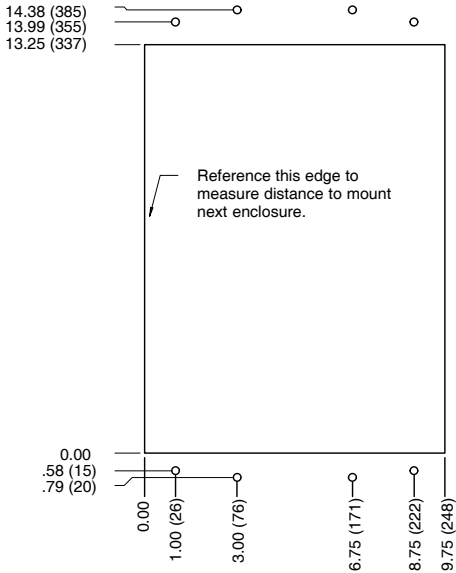

Holes coded "A" and "B".  
Mounting hole locations for surface mounting. Recommended hardware 1/4"-20 or M6 thru hole .25"(6.4mm) dia.

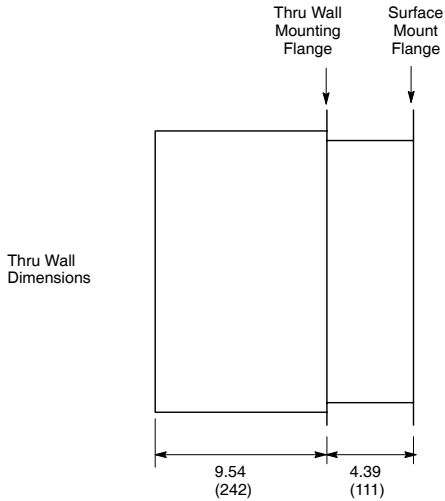
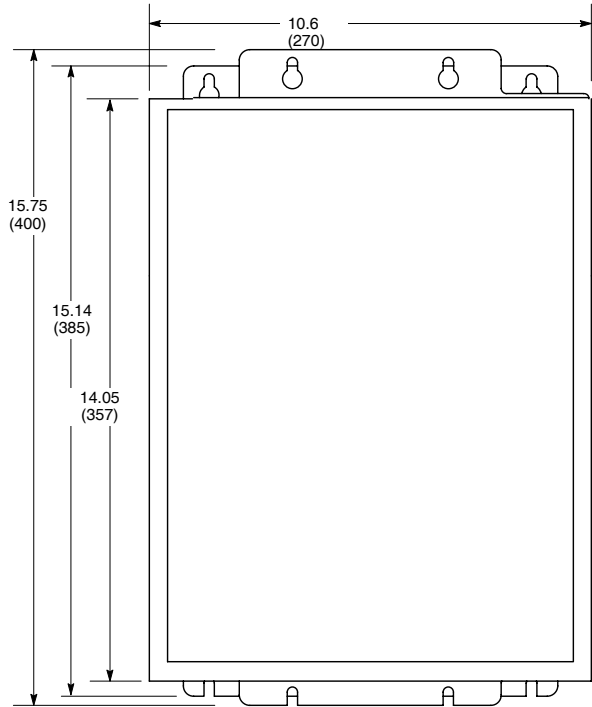

**25M-PO Dimensions** Continued

**25M-PO Mounting Considerations**

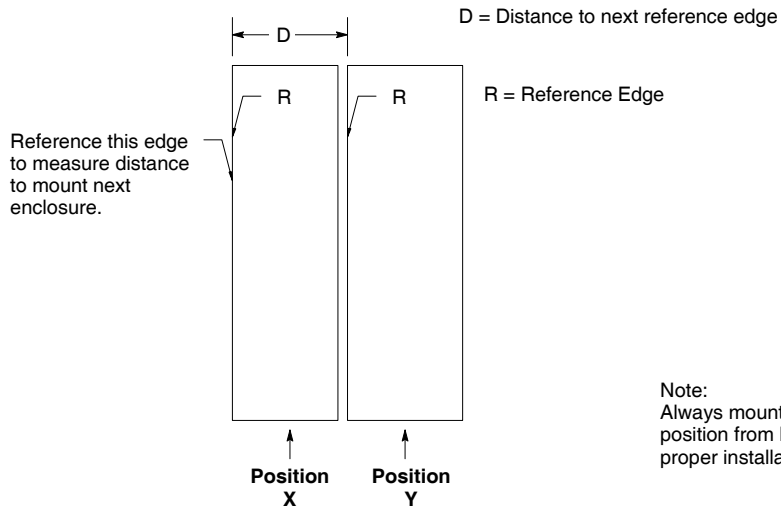

Note:  
Always mount the PSM in the first position from left to right. This allows proper installation of the power bus bars.

**Mounting and Power Bus Bar Information**

Position X Size	Position Y Size	Distance to next reference edge "D"	Power Bus Bar		
			Part Number	Length	Hole Spacing
D	D	10.6 (270)	V1093641	11.74(298)	10.64(270)
D	C	10.5 (267)	V1093651	4.93(125)	3.78(96)
D	B	10.5 (267)	V1093651	4.93(125)	3.78(96)
C	C	5.5 (140)	V1093661	6.82(173)	5.52(140)
C	B	5.5 (140)	V1093661	6.82(173)	5.52(140)
B	D	4.3 (109)	V1093681	12.10(307)	11.03(280)
B	B	4.2 (106)	V1093671	5.24(133)	4.18(106)
B	C	4.2 (106)	V1093671	5.24(133)	4.18(106)

## Appendix A

### Parameter Values (Version 1.06)

#### Parameter Block Values Level 1

Level 1 Blocks					
Block Title	Parameter	P#	Adjustable Range	Factory Setting	User Setting
PRESET SPEEDS	PRESET SPEED #1	1001	0-MAX Speed	0 RPM	
	PRESET SPEED #2	1002	0-MAX Speed	0 RPM	
	PRESET SPEED #3	1003	0-MAX Speed	0 RPM	
	PRESET SPEED #4	1004	0-MAX Speed	0 RPM	
	PRESET SPEED #5	1005	0-MAX Speed	0 RPM	
	PRESET SPEED #6	1006	0-MAX Speed	0 RPM	
	PRESET SPEED #7	1007	0-MAX Speed	0 RPM	
	PRESET SPEED #8	1008	0-MAX Speed	0 RPM	
	PRESET SPEED #9	1009	0-MAX Speed	0 RPM	
	PRESET SPEED #10	1010	0-MAX Speed	0 RPM	
	PRESET SPEED #11	1011	0-MAX Speed	0 RPM	
	PRESET SPEED #12	1012	0-MAX Speed	0 RPM	
	PRESET SPEED #13	1013	0-MAX Speed	0 RPM	
	PRESET SPEED #14	1014	0-MAX Speed	0 RPM	
	PRESET SPEED #15	1015	0-MAX Speed	0 RPM	
ACCEL/DECEL RATE	ACCEL TIME #1	1101	0 to 3600 Seconds	3.0 SEC	
	DECEL TIME #1	1102	0 to 3600 Seconds	3.0 SEC	
	S-CURVE #1	1103	0-100%	0 %	
	ACCEL TIME #2	1104	0 to 3600 Seconds	3.0 SEC	
	DECEL TIME #2	1105	0 to 3600 Seconds	3.0 SEC	
	S-CURVE #2	1106	0-100%	0 %	
JOG SETTINGS	JOG SPEED	1201	0-MAX Speed	200 RPM	
	JOG ACCEL TIME	1202	0 to 3600 Seconds	3.0 SEC	
	JOG DECEL TIME	1203	0 to 3600 Seconds	3.0 SEC	
	JOG S-CURVE TIME	1204	0-100%	0 %	
KEYPAD SETUP	KEYPAD STOP KEY	1301	REMOTE ON (Stop key active during remote operation). REMOTE OFF (Stop key inactive during remote operation).	REMOTE ON	
	KEYPAD STOP MODE	1302	COAST, REGEN	REGEN	
	KEYPAD RUN FWD	1303	OFF, ON	ON	
	KEYPAD RUN REV	1304	OFF, ON	ON	
	KEYPAD JOG FWD	1305	OFF, ON	ON	
	KEYPAD JOG REV	1306	OFF, ON	ON	
	LOC. HOT START	1307	OFF, ON	OFF	

**Parameter Block Values Level 1** Continued

Level 1 Blocks - Continued					
Block Title	Parameter	P#	Adjustable Range	Factory Setting	User Setting
INPUT	OPERATING MODE	1401	KEYPAD STANDARD RUN 15SPD 3SPD ANA 2WIRE 3SPD ANA 3WIRE SERIAL BIPOLAR PROCESS MODE EPOT- 2WIRE EPOT- 3WIRE	KEYPAD	
	COMMAND SELECT	1402	POTENTIOMETER +/-10 VOLTS +/-5 VOLTS 4 TO 20 mA 10V W/TORQ FF EXB PULSE FOL 5V EXB 10V EXB 4-20mA EXB 3-15 PSI EXB TACHOMETER EXB SERIAL NONE	+/-10 VOLTS	
	ANA CMD INVERSE	1403	OFF, ON	OFF	
	ANA CMD OFFSET	1404	-20.0 To +20.0%	0.0 %	
	ANA 2 DEADBAND	1405	0-10.00 V	0.00 V	
	ANA 1 CUR LIMIT	1406	OFF, ON	OFF	
OUTPUT	OPTO OUTPUT #1	1501	READY ZERO SPEED AT SPEED OVERLOAD	READY	
	OPTO OUTPUT #2	1502	KEYPAD CONTROL AT SET SPEED FAULT FOLLOWING ERR MOTR DIRECTION	ZERO SPEED	
	OPTO OUTPUT #3	1503	DRIVE ON CMD DIRECTION AT POSITION	AT SPEED	
	OPTO OUTPUT #4	1504	OVER TEMP WARN PROCESS ERROR DRIVE RUN SERIAL	FAULT	
	ZERO SPD SET PT	1505	0-MAX Speed	200 RPM	
	AT SPEED BAND	1506	0-1000 RPM	100 RPM	
	SET SPEED	1507	0-MAX Speed	Rated Motor Speed	

**Parameter Block Values Level 1** Continued

Level 1 Blocks - Continued					
Block Title	Parameter	P#	Adjustable Range	Factory Setting	User Setting
OUTPUT (Continued) OUTPUT (Continued)	ANALOG OUT #1	1508	ABS SPEED ABS TORQUE SPEED COMMAND PWM VOLTAGE FLUX CURRENT CMD FLUX CUR LOAD CURRENT CMD LOAD CUR MOTOR CURRENT LOAD COMPONENT QUAD VOLTAGE DIRECT VOLTAGE	ABS SPEED	
	ANALOG OUT #2	1509	AC VOLTAGE BUS VOLTAGE TORQUE POWER VELOCITY OVERLOAD PH2 CURRENT PH1 CURRENT PROCESS FDBK SETPOINT CMD POSITION SERIAL	MOTOR CURRENT	
	ANALOG #1 SCALE	1510	10-100%	100%	
	ANALOG #2 SCALE	1511	10-100%	100%	
	ANA OUT OFFSET	1512	-20.0 to 20%	0.0	
	POSITION BAND	1513	1-32767 Counts	CALC	
	VECTOR CONTROL	CTRL BASE SPEED	1601	0-MAX Speed	CALC
	FEEDBACK FILTER	1602	0-7	CALC	
	FEEDBACK ALIGN	1603	REVERSE, FORWARD	FORWARD	
	CURRENT PROP GAIN	1604	0-1000	80	
	CURRENT INT GAIN	1605	0-400Hz	150Hz	
	SPEED PROP GAIN	1606	0-1000	10	
	SPEED INT GAIN	1607	0-9.99 Hz	1.00	
	SPEED DIFF GAIN	1608	0-100	0	
	POSITION GAIN	1609	0-9999	31	
	SLIP FREQUENCY	1610	0-20.00 Hz	CALC	
	STATOR R1	1611	0-65.535	CALC	
	STATOR X1	1612	0-65.535	CALC	
LEVEL 2 BLOCK	ENTERS LEVEL 2 MENU				
PRESS ENTER FOR PROGRAMMING EXIT	Exit programming mode and return to display mode.				



## Parameter Block Values Level 2

Level 2 Blocks					
Block Title	Parameter	P#	Adjustable Range	Factory Setting	User Setting
OUTPUT LIMITS	MIN OUTPUT SPEED	2001	0-MAX Speed	0 RPM	
	MAX OUTPUT SPEED	2002	0-30000 RPM	Rated Motor Speed	
	PK CURRENT LIMIT	2003	0-PEAK RATED CURRENT	PK Control Rating	
	PWM FREQUENCY	2004	1-16.0kHz	8.5kHz	
	CUR RATE LIMIT	2005	0-10.000 SEC	0.004 SEC	
CUSTOM UNITS	DECIMAL PLACES	2101	0-5	5	
	VALUE AT SPEED	2102	0-65535 / 0-65535	00000/ 01000 RPM	
	UNITS OF MEASURE	2103	Selection of 9 Character Sets	-	
PROTECTION	OVERLOAD	2201	FOLDBACK, FAULT	FOLDBACK	
	EXTERNAL TRIP	2202	OFF, ON	OFF	
	LOCAL ENABLE INP	2203	OFF, ON	OFF	
	FOLLOWING ERROR	2204	OFF, ON	OFF	
	TORQUE PROVING	2205	OFF, ON	OFF	
MISCELLANEOUS	RESTART AUTO/MAN	2301	MANUAL, AUTOMATIC	MANUAL	
	RESTART FAULT/HR	2302	0-10	0	
	RESTART DELAY	2303	0-120 SECONDS	0 SEC	
	FACTORY SETTINGS	2304	NO, YES	NO	
	HOMING SPEED	2305	0-MAX Speed	100 RPM	
	HOMING OFFSET	2306	0-65535 CNTS	1024	
SECURITY CONTROL	SECURITY STATE	2401	OFF LOCAL SECURITY SERIAL SECURITY TOTAL SECURITY	OFF	
	ACCESS TIMEOUT	2402	0-600 SEC	0 SEC	
	ACCESS CODE	2403	0-9999	9999	
MOTOR DATA	MOTOR VOLTAGE	2501	150-999 VOLTS	Factory Set	
	MOTOR RATED AMPS	2502	0-999.9	Factory Set	
	MOTOR RATED SPD	2503	0-32767 RPM	1750 RPM	
	MOTOR RATED FREQ	2504	0-500 Hz	60.0 Hz	
	MOTOR MAG AMPS	2505	0-85% Rated Current	CALC	
	ENCODER COUNTS	2506	0-65535 CNTS	1024	
	RESOLVER SPEEDS	2507	0 to 10 SPEED	1	
	CALC PRESETS	2508	NO, YES	NO	

**Parameter Block Values Level 2** Continued

Level 2 Blocks - Continued					
Block Title	Parameter	P#	Adjustable Range	Factory Setting	User Setting
PROCESS CONTROL	PROCESS FEEDBACK	2601	POTENTIOMETER +/-10VOLTS +/-5 VOLTS 4 TO 20mA 5V EXB 10V EXB 4-20mA EXB 3-15 PSI EXB TACHOMETER EXB NONE	NONE	
	PROCESS INVERSE	2602	OFF, ON	OFF	
	SETPOINT SOURCE	2603	POTENTIOMETER +/-10VOLTS +/-5 VOLTS 4 TO 20mA 5V EXB 10V EXB 4-20mA EXB 3-15 PSI EXB TACHOMETER EXB NONE SETPOINT CMD	SETPOINT CMD	
	SETPOINT COMMAND	2604	-100% to +100%	0.0 %	
	SET PT ADJ LIMIT	2605	0-100%	10.0 %	
	PROCESS ERR TOL	2606	1-100%	10 %	
	PROCESS PROP GAIN	2607	0-2000	0	
	PROCESS INT GAIN	2608	0-9.99 HZ	0.00	
	PROCESS DIFF GAIN	2609	0-1000	0	
	FOLLOW I:O RATIO	2610	(1-65535) : (1:20)	1:1	
	FOLLOW I:O OUT	2611	(1-65535) : (1-65535)	1:1	
	MASTER ENCODER	2612	50- 65535	1024	
COMMUNICATIONS	PROTOCOL	2801	RS-232 ASCII, RS-485 ASCII, RS-232 BBP, RS-485 BBP	RS-232 ASCII	
	BAUD RATE	2802	9600, 19.2KB, 38.4KB, 57.6KB, 115.2KB, 230.4KB, 460.8KB, 921.6KB	9600	
	DRIVE ADDRESS	2803	0 - 31	0	

**Parameter Block Values Level 2** Continued

Level 2 Blocks - Continued					
Block Title	Parameter	P#	Adjustable Range	Factory Setting	User Setting
AUTO-TUNING	<b>CALC PRESETS</b>	CALC	NO, YES	NO	
	<b>CMD OFFSET TRM</b> Measures and trims out offset voltage at Analog Input #2 (J1-4 & J1-5).	AU1			
	<b>CUR LOOP COMP</b> Measures current response while running motor at one half the rated motor current.	AU2			
	<b>STATOR R1</b> Measures stator resistance	AU3			
	<b>FLUX CUR SETTING</b> Sets the Motor Mag Amps.	AU4			
	<b>FEEDBACK TESTS</b> Checks the Encoder Counts and Feedback Align values.	AU5			
	<b>SLIP FREQ TEST</b> Measures motor Slip Frequency during motor acceleration/deceleration at repeated intervals.	AU6			
	<b>SPD CNTRLR CALC</b> Measures the motor current to acceleration ratio during motor rotation. This procedure adjusts the Speed INT Gain and Speed PROP Gain parameters.	AU7			
LEVEL 1 BLOCK	Enters Level 1 Menu				
PRESS ENTER FOR PROGRAMMING EXIT	Exit programming mode and return to display mode.				

**Appendix B**

---

---

## Remote Keypad Mounting Template

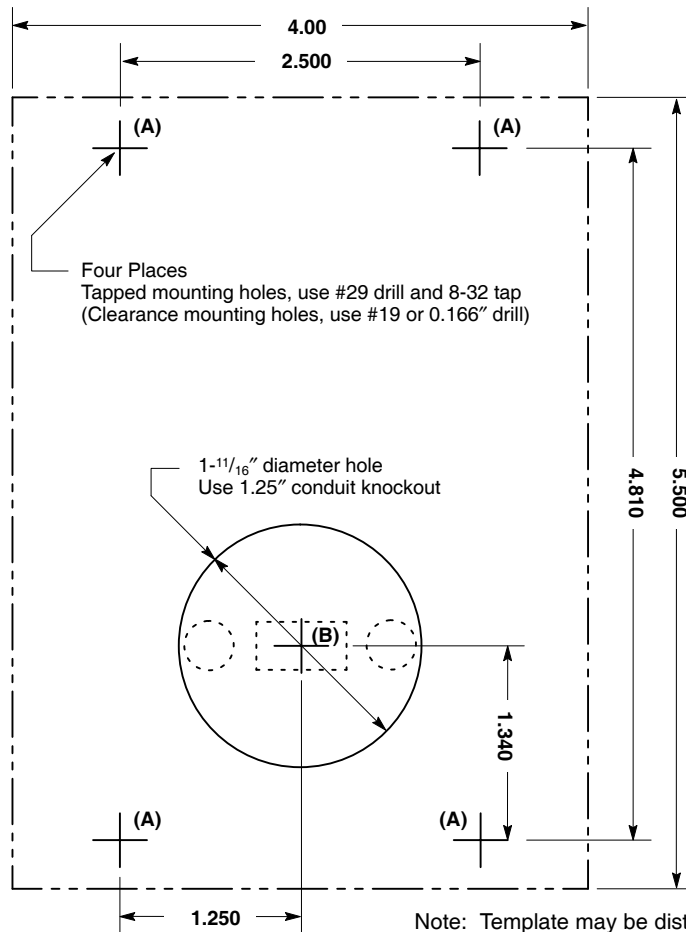



\* 7 2 5 - 0 3 0 1 \*

**BALDOR<sup>®</sup>**  
**MOTORS AND DRIVES**

BALDOR ELECTRIC COMPANY  
P.O. Box 2400  
Ft. Smith, AR 72901-2400  
(501) 646-4711  
Fax (501) 648-5792

